



TOWN OF HUDSON

Board of Selectmen



12 School Street · Hudson, New Hampshire 03051 · Tel: 603-886-6024 · Fax: 603-598-6481

BOARD OF SELECTMEN MEETING

March 22, 2022

Board of Selectmen Meeting Room, Town Hall

Agenda

1. CALL TO ORDER
2. PLEDGE OF ALLEGIANCE
3. ATTENDANCE
4. PUBLIC INPUT
5. RECOGNITIONS, NOMINATIONS & APPOINTMENTS
 - A. Nomination
 - 1) Conservation Commission - (1 alternate member term to expire 12/31/23)

Linda Krisciunas
6. CONSENT ITEMS
 - A. Assessing Items
 - 1) Disabled Exemption Re-qualifications: 104 Wason Rd. - map 212/ lot 011; 10 Walnut St. - map 247/ lot 054; 28 Cottonwood Dr. - map 203/ lot 059; 3 Forest Rd. - map 138/ lot 023; 47 Riverside Dr. - map 190/ lot 130; 14 Winnhaven Dr. - map 197/ lot 058
 - 2) Elderly Exemption Re-qualifications: 17 Melendy Rd. - map 191/ lot 139; 8 Newton St. - map 174/ lot 070; 20 Williams Dr. - map 253/ lot 053; 17 Lawrence Rd. - map 153/ lot 006; 59 Lowell Rd. - map 197/ lot 041; 158 B Robinson Rd. - map 111/ lot 047/ sub 00; 328 Abbott Farm Ln. - map 165/ lot 141/ sub 328
41 Bonnie Heights Ln. - map 158/ lot 001/ sub 013; 214 Pheasant Run Rd. - map 168/ lot 068/ sub 014; 87 Robinson Rd. - map 117/ lot 023; 11 Burnham Rd. - map 175/ lot 080; 11B Doveton Ln. - map 156/ lot 005/ sub 007; 1 Garrison Farm Rd. - map 156/ lot 001; 11 Clement Rd. - map 161/ lot 052;

103 Ferry St. - map 175/ lot 158; 5 Shoal Creek Rd. - map 148/ lot 040/ sub 119; 19B Holly Ln. - map 216/ lot 018/ sub 027; 20 Adelaide St. - map 182/ lot 179; 46 Highland St. - map 174/ lot 108; 105 Highland St. - map 167/ lot 062
16 Village Ln. - map 175/ lot 034/ sub 007; 7 Pond View Dr. - map 175/ lot 034/ sub 028; 35 Bowes Cir. - map 147/ lot 029/ sub 013; 6 Village Ln. - map 175/ lot 034/ sub 002; 941 Fox Hollow Dr. - map 204/ lot 006/ sub 941; 53 River Rd. - map 246 /lot 002; 10 Regina St. - map 191/ lot 010; 47 Lexington Ct. - map 147/ lot 017/ sub 002; 35 Mobile Dr. - map 178/ lot 013/ sub 045; 11 Bowes Cir. - map 147/ lot 029/ sub 001; 1 Summer Ave. - map 165/ lot 131; 12 Gambia St. - map 165/ lot 021; 67 Mobile Dr. - map 178/ lot 013/ sub 053

3) Certification of Yield Taxes Assessed/Timber Warrant: 285-299 Webster Street, map 128, lot 010, sub 000, 001, 002; 36 Executive Drive, map 215, lot 004, sub 000

4) All Veterans Tax Credit: 8A Shelley Drive, map 204, lot 049, sub 001

5) Veteran Tax Credit: 18A Chagnon Lane, map 116, lot 013, sub 001; 16A Chandler Court, map 177, lot 005, sub 152

6) Disabled Veteran Tax Credits: 58 Brackett Lane, map 156, lot 005, sub 036; 13A Rangers Drive, map 151, lot 027, sub 001

7) Elderly Exemption: 7 Porter Ave, map 190, lot 070

8) Solar Exemption: Robert and Helene Wherry, 37 James Way, map 230, lot 022, sub 019

9) Tax Warrant- Tax Deferral Conversion: 50 Mobile Drive, map 178, lot 13-47

B. Licenses & Permits & Policies

- 1) Tag Day Permit - American Legion Post 247
- 2) 2022 Permit - Hudson Speedway

C. Donations - none

D. Acceptance of Minutes

- 1) Minutes of February 22, 2022
- 2) Minutes of March 1, 2022

F. Calendar

3/23	7:00	Planning Board - Buxton Meeting Room
3/24	3:30	Trustees of the Trust Funds - Buxton Meeting Room
3/24	6:00	Conservation Commission - Site Walk
3/24	7:00	Zoning Board of Adjustment - Buxton Meeting Room
3/28	7:00	Sustainability Committee - Buxton Meeting Room
4/06	8:30a	Highway Safety Committee - Buxton Meeting Room
4/06	7:00	Budget Committee - Buxton Meeting Room
4/07	7:00	Recreation Committee - CANCELLED
4/11	7:00	Conservation Commission - Buxton Meeting Room
4/11	7:00	Cable Utility Committee - HCTV Meeting Room
4/12	7:00	Board of Selectmen - BOS Meeting Room

7. OLD BUSINESS - None

8. NEW BUSINESS

- A. Recreation Department Summer Staff Rate of Pay Review
- B. Transfer Station Upgrades - Construction Services Award
- C. Transfer Station Upgrades - Inspection Services Award
- D. Bush Hill Road Improvement Opportunity
- E. Town Wide Paving Contract
- F. Radio Infrastructure Replacement Project
- G. 2022 Town Election Debrief
 - Town Moderator - Election Update
 - Town Clerk - Debrief & Synopsis of Absentee Ballot Issues
 - Review of Warrant Tax Impact Notes
 - Election Day Candidate Etiquette - Review of Town Ordinances or Bylaws
- H. Purchase of a 2022 Ford Police Utility Vehicle
- I. Purchase of Four (4) Ford Police Utility Vehicles
- J. Financing for Police Facility Expansion and Renovation
- K. NHDOT Project 43058 - Resurfacing Route 111
- L. VFW Post 5791 Loyalty Day Award Nomination
- M. February 2022 Revenues and Expenditures
- N. Settlement Agreement - Heidi Jakoby, et al v. Town of Hudson
- O. Proposal for Legal Services 2022-2023

P. Discussion - Budget Committees Vote to Change By-laws

Q. Nomination and Appointment - Board of Selectmen Chairman and Vice-Chairman

9. REMARKS BY TOWN ADMINISTRATOR

10. REMARKS BY SCHOOL BOARD

11. OTHER BUSINESS/REMARKS BY THE SELECTMEN

12. NONPUBLIC SESSION

RSA 91-A: 3 II (a) The dismissal, promotion, or compensation of any public employee or the disciplining of such employee, or the investigation of any charges against him or her, unless the employee affected (1) has a right to a meeting and (2) requests that the meeting be open, in which case the request shall be granted. **(b)** The hiring of any person as a public employee.

THE SELECTMEN MAY ALSO GO INTO NON-PUBLIC SESSION FOR ANY OTHER SUBJECT MATTER PERMITTED PURSUANT TO RSA 91-A:3 (II).

13. ADJOURNMENT

Reminder...

**Items for the next agenda, with complete backup, must be in the Selectmen's Office
no later than 12:00 noon on Thursday, April 7, 2022**

Agenda 3.22.22

RECEIVED

MAR 16 2022

TOWN OF HUDSON
SELECTMEN'S OFFICE

5A-1



How may we help you?

Submission #57

[Print](#) [Resend e-mails](#)

[Previous submission](#)

[Next submission](#)

Submission information

Form: Board & Committee Application

Submitted by Visitor (not verified)

Tue, 03/15/2022 - 9:37am

73.68.78.176

Date

Tue, 03/15/2022

First Name

linda

Last Name

krisciunas

Street Address

72 standish lane

Home Phone

5083263431

Work Phone**E-mail Address:**

adnil5588@yahoo.com

Education

BS and MS Engineering, MBA, registered to practice patent law

Occupation (or former occupation if retired)

Patent Portfolio Director

Special Interests**Professional/Community Activities**

volunteer during elections, Hudson Old Home Days and other local events

Reference

William Collins

Reason for Applying

I am interested in volunteering more with the town and learning how various groups work together to grow Hudson.

Please check the area in which you are interested in serving:

Alternate

Please select area of interest

Conservation Commission

Areas of Expertise

Other

Are you a Hudson, NH resident?

yes

[Previous submission](#)

[Next submission](#)



[Home](#) [Logout](#) [Contact Us](#) [Dashboard](#) [Website Credits](#)

12 School Street | Hudson, NH 03051 | (603) 886-6000

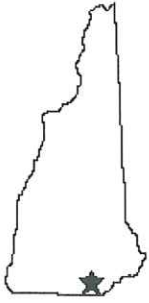

TOWN OF HUDSON

Office of the Assessor

Jim Michaud
Chief Assessor, CAE
email: jmichaud@hudsonnh.gov

www.hudsonnh.gov



Agenda
3-22-22

12 School Street · Hudson, New Hampshire 03051 · Tel: 603-886-6009 · Fax: 603-598-6481

6A-1

TO: Board of Selectmen
Steve Malizia, Town Administrator

DATE: March 22, 2022

FROM: Jim Michaud, Chief Assessor 

RE: Disabled Exemption Re-qualification:

RECEIVED

MAR 17 2022

TOWN OF HUDSON
SELECTMEN'S OFFICE

I recommend the Board of Selectmen sign the PA-29 forms granting Disabled Exemptions to the property owners listed below. The residents have provided the proper documentation to show they qualify for this exemption.

Steven and Christina Bennett – 104 Wason Rd. – map 212/ lot 011
Deborah Delgenio – 10 Walnut St. – map 247/ lot 054
Charles and Therese Brown – 28 Cottonwood Dr. – map 203/ lot 059
Denise Davis – 3 Forest Rd. – map 138/ lot 023
Dennis Heroux – 47 Riverside Dr. – map 190/ lot 130
Gerard Levasseur – 14 Winnhaven Dr. – map 197/ lot 058

MOTION: Motion to grant Disabled Exemptions to the property owners referenced in the above request.



TOWN OF HUDSON
Office of the Assessor



Jim Michaud
Chief Assessor, CAE
email: jmichaud@hudsonnh.gov

www.hudsonnh.gov

12 School Street · Hudson, New Hampshire 03051 · Tel: 603-886-6009 · Fax: 603-598-6481

6A-2

TO: Board of Selectmen
Steve Malizia, Town Administrator

DATE: March 22, 2022

FROM: Jim Michaud, Chief Assessor

RECEIVED

MAR 17 2022

TOWN OF HUDSON
SELECTMEN'S OFFICE

RE: Elderly Exemption Re-qualifications

I recommend the Board of Selectmen sign the PA-29 form granting Elderly Exemptions to the property owners listed below. The residents have provided the proper documentation to show they qualify for this exemption.

- Mark Christopher – 17 Melendy Rd. – map 191/ lot 139
- Cheryl Trudeau – 8 Newton St. – map 174/ lot 071
- Rose Russell – 20 Williams Dr. – map 253/ lot 053
- Leo and Maria McCarthy – 17 Lawrence Rd. – map 153/ lot 006
- Diane Briand – 59 Lowell Rd. – map 197/ lot 041
- Cynthia Stone – 158B Robinson Rd. – map 111/ lot 047/ sub 002
- Janice Wells – 328 Abbott Farm Ln. – map 165/ lot 141/ sub 328
- Sandra Arsenault – 41 Bonnie Heights Ln. – map 158/ lot 001/ sub 013
- Donald Nichols – 214 Pheasant Run Rd. – map 168/ lot 068/ sub 014
- James and Illa Hetzer – 87 Robinson Rd. – map 117/ lot 023
- Carlton White – 11 Burnham Rd. – map 175/ lot 080
- Jean Levesque – 11B Doveton Ln. – map 156/ lot 005/ sub 007
- Jeanne Lang – 1 Garrison Farm Rd. – map 156/ lot 001
- Alice Coakley – 11 Clement Rd. – map 161/ lot 052
- Lorraine Dionne – 103 Ferry St. – map 175/ lot 158
- Linda Cobleigh – 5 Shoal Creek Rd. – map 148/ lot 040/ sub 119
- Frances Stratton – 19B Holly Ln. – map 216/ lot 018/ sub 027
- Gary and Michele Milosh – 20 Adelaide St. – map 182/ lot 179
- Carol Ann Viens – 46 Highland St. – map 174/ lot 108
- Gerald Casey Jr. – 105 Highland St. – map 167/ lot 062
- Ella and David Gagne – 16 Village Ln. – map 175/ lot 034/ sub 007
- Roger and Doris Coutu – 7 Pond View Dr. – map 175/ lot 034/ sub 028

Pamela Forrence – 35 Bowes Cir. – map 147/ lot 029/ sub 013
Doris Gioseffi – 6 Village Ln. – map 175/ lot 034/ sub 002
Alice Pinard – 941 Fox Hollow Dr. – map 204/ lot 006/ sub 941
John Sullivan – 53 River Rd. – map 246 /lot 002
James and Alfreda Rousseau – 10 Regina St. – map 191/ lot 010
Theresa Rancourt – 47 Lexington Ct. – map 147/ lot 017/ sub 002
Arthur and Cecile Hall – 35 Mobile Dr. – map 178/ lot 013/ sub 045
Barbara Whiting – 11 Bowes Cir. – map 147/ lot 029/ sub 001
Joan Tyler – 1 Summer Ave. – map 165/ lot 131
Dolores Paradise – 12 Gambia St. – map 165/ lot 021
Raymond and Catherine Dery – 67 Mobile Dr. – map 178/ lot 013/ sub 053

***MOTION: Motion to grant Elderly Exemptions to the property owners
referenced in the above request.***

Report
3-22-22



TOWN OF HUDSON

Office of the Assessor

Jim Michaud
Chief Assessor, CAE

email: jmichaud@hudsonnh.gov

www.hudsonnh.gov

12 School Street · Hudson, New Hampshire 03051 · Tel: 603-886-6009 · Fax: 603-598-6481



6A-3

TO: Board of Selectmen
Steve Malizia, Town Administrator

DATE: March 22, 2022

FROM: Jim Michaud, Chief Assessor 

RE: Certification of Yield Taxes Assessed/Timber Warrant:

285-299 Webster St. – map 128/ lot 010/ sub 000, 001, 002
36 Executive Drive – map 215/ lot 004/ sub 000

RECEIVED

MAR 17 2022

TOWN OF HUDSON
SELECTMEN'S OFFICE

I recommend the Board of Selectmen sign the following attached Certifications of Yield Taxes Assessed and Timber Tax Warrants for:

M.R. Lacasse Homes, LLC.
9 Scenic Lane
Hudson, NH 03051

36 Executive Owner, LLC.
7315 Wisconsin Ave, 200W
Bethesda, MD 20814

CERTIFICATION OF YIELD TAXES ASSESSED
INTENT FILED DURING TAX YEAR: April 1, 2021 to March 31, 2022

TOWN / CITY OF: HUDSON
 COUNTY OF: HILLSBOROUGH COUNTY
 CERTIFICATION DATE: March 22, 2022

SEND SIGNED COPY TO: DEPT. OF REVENUE ADMINISTRATION
 MUNICIPAL AND PROPERTY DIVISION
 P.O. BOX 487
 CONCORD, NH 03302-0487

 (Selectmen/assessor)

 (Selectmen/assessor)

 (Selectmen/assessor)

 (Selectmen/assessor)

 (Selectmen/assessor)

# 1	# 4	# 5	# 6	# 6	# 7	# 8	# 9	# 10
NAME OF OWNER	SPECIES	NUMBER OF BOARD FEET IN THOUSANDS	NUMBER OF TONS	NUMBER OF CORDS	STUMPAGE VALUE	TOTAL ASSESSED VAL.	TAX AT 10 %	
M.R. LACASSE HOMES, LLC 9 SCENIC LANE HUDSON, NH 03051	WHITE PINE	8.760			\$181.25	\$1,587.75	\$158.78	
	HEMLOCK	2.270			\$66.00	\$149.82	\$14.98	
	RED PINE	0.000			\$10.00	\$0.00	\$0.00	TOTAL TAX
ACCOUNT OR SERIAL #: 11894	SPRUCE & FIR	0.000			\$40.00	\$0.00	\$0.00	DUE ON THIS
	HARD MAPLE	0.000			\$120.00	\$0.00	\$0.00	OPERATION
# 2 BY WHICH LOT WAS DESIGNATED IN NOTICE OF INTENT MAP & LOT NUMBER 128-010-002	WHITE BIRCH	0.000			\$30.00	\$0.00	\$0.00	(TOTAL OF COL. # 9)
	YELLOW BIRCH	0.000			\$50.00	\$0.00	\$0.00	
	OAK	13.170			\$388.25	\$5,113.25	\$511.33	
	ASH	0.000			\$75.00	\$0.00	\$0.00	
	SOFT MAPLE	0.620			\$156.25	\$96.88	\$9.69	
	BEECH/PALLET/TIE LOGS	0.000			\$20.00	\$0.00	\$0.00	
	OTHERS :	0.000			\$0.00	\$0.00	\$0.00	
	OTHERS :	0.000			\$0.00	\$0.00	\$0.00	
					TONS	CORDS		
# 3 OPERATION NUMBER 21-229-04-T	SPRUCE & FIR		0.00		\$ -	\$0.00	\$0.00	
	HARDWOOD & ASPEN		0.00		\$ 0.50	\$0.00	\$0.00	
	PINE		0.00		\$ -	\$0.00	\$0.00	
	HEMLOCK		0.00		\$ -	\$0.00	\$0.00	
	BIOMASS CHIPS		251.30		\$ 0.85	\$213.61	\$21.36	
	HIGH GRADE SPRUCE		0.00		\$ 20.00	\$0.00	\$0.00	
	CORDWOOD			0.00	\$ 8.00	\$0.00	\$0.00	
						\$7,161.31	\$716.14	

**ORIGINAL WARRANT
YIELD TAX LEVY
March 22, 2022
THE STATE OF NEW HAMPSHIRE**

HILLSBOROUGH COUNTY

TO: Roger Ordway Jr., Collector of Taxes for Town of **HUDSON**, in said county:

In the name of said State you are hereby directed to collect on or before thirty (30) days from date of bill from the person(s) named herewith committed to you, the Yield Tax set against their name(s), amounting in all to the sum of : **\$716.14**, with interest at eighteen (18%) percent per annum from the due date and on all sums not paid on or before that day. We further order you to pay all monies collected to the treasurer of said town, or treasurer's designee as provided in RSA 41:29, VI, at least on a weekly basis, or daily when receipts exceed \$1,500.00 or more often when directed by the Commissioner of Revenue Administration.

Given under our hands and seal at HUDSON

(Selectmen/assessor)

(Selectmen/assessor)

(Selectmen/assessor)

(Selectmen/assessor)

(Selectmen/assessor)

DATE SIGNED: March 22, 2022

NAME & ADDRESS	MAP & LOT	OPERATION #	YIELD TAX DUE
M.R. LACASSE HOMES, LLC 9 SCENIC LANE HUDSON, NH 03051	128-010-002	21-229-04-T	\$716.14

TAX DUE DATE: April 21, 2022 TOTAL YIELDTAX: \$716.14

TIMBER CUT FOR INTENTS FILED DURING: April 1, 2021 to March 31, 2022

TOWN OF HUDSON

12 School Street

Hudson, NH 03051

603-886-6003

M.R. LACASSE HOMES, LLC

9 SCENIC LANE
HUDSON, NH 03051

YIELD TAX ON TIMBER CUT

TAX ACCOUNT & SERIAL I.D. NUMBER: 11894
TAX MAP & LOT NUMBER: 128-010-002
YIELD TAX OPERATION NUMBER: 21-229-04-T
DATE OF YIELD TAX BILL: 3/22/2022
AMOUNT COMMITTED TO ME
FOR COLLECTION PER RSA 79: **\$716.14**

***** 18% APR INTEREST WILL BE CHARGED AFTER 4/21/2022 ON UNPAID TAXES *****

APPEAL: an owner may, within 90 days of notice of the tax, appeal to the assessing officials in writing for an abatement from the original assessment, but no owner shall be entitled to an abatement unless he has complied with the provisions of RSA 79:10 and 11. (RSA 79:8)

TAX OFFICE HOURS: MONDAY-FRIDAY 8 AM - 4:30 PM

Sincerely,

Roger Ordway, Jr.
Tax Collector

TOWN: HUDSON
 COUNTY: HILLSBOROUGH COUNTY
 OWNER: M.R. LACASSE HOMES, LLC
 OWNER: .
 ADDRESS: 9 SCENIC LANE
 ADDRESS: HUDSON, NH 03051

INTENT FILED DURING TAX YEAR: April 1, 2021 to March 31, 2022

ACCOUNT & SERIAL #: 11894
 MAP & LOT #: 128-010-002
 OPERATION #: 21-229-04-T
 DATE OF BILLING: March 22, 2022

SPECIES	LOW MBF	HIGH MBF			RANGE DIFFERENCE		RATING %	STUMPAGE VALUE *	# BOARD FEET IN THOUSANDS		
WHITE PINE	\$75.00	\$200.00			\$125.00		0.85	\$ 181.25	8.760		
HEMLOCK	\$15.00	\$75.00			\$60.00		0.85	\$ 66.00	2.270		
RED PINE	\$10.00	\$60.00			\$50.00		0.00	\$ 10.00	0.000		
SPRUCE & FIR	\$40.00	\$160.00			\$120.00		0.00	\$ 40.00	0.000		
HARD MAPLE	\$120.00	\$400.00			\$280.00		0.00	\$ 120.00	0.000		
WHITE BIRCH	\$30.00	\$100.00			\$70.00		0.00	\$ 30.00	0.000		
YELLOW BIRCH	\$50.00	\$250.00			\$200.00		0.00	\$ 50.00	0.000		
OAK	\$180.00	\$425.00			\$245.00		0.85	\$ 388.25	13.170		
ASH	\$75.00	\$250.00			\$175.00		0.00	\$ 75.00	0.000		
SOFT MAPLE	\$50.00	\$175.00			\$125.00		0.85	\$ 156.25	0.620		
BEECH/PALLET/TIE LOGS	\$20.00	\$85.00			\$65.00		0.00	\$ 20.00	0.000		
OTHERS:	\$0.00	\$0.00			\$0.00		0.00	\$ -	0.000		
OTHERS:	\$0.00	\$0.00			\$0.00		0.00	\$ -	0.000		
TONS & CORDS	TONS LOW	TONS HIGH	CORDS LOW	CORDS HIGH	TONS	CORDS	RATING %	STUMPAGE VALUE TONS *	STUMPAGE VALUE CORDS *	#TONS	#CORDS
SPRUCE & FIR	\$0.00	\$1.00			\$1.00		0.00	\$ -		0.000	
HARDWOOD & ASPEN	\$0.50	\$5.00			\$4.50		0.00	\$ 0.50		0.000	
PINE	\$0.00	\$1.00			\$1.00		0.00	\$ -		0.000	
HEMLOCK	\$0.00	\$5.00			\$5.00		0.00	\$ -		0.000	
BIOMASS CHIPS	\$0.00	\$1.00			\$1.00		0.85	\$ 0.85		251.300	
HIGH GRADE SPRUCE	\$20.00	\$30.00			\$10.00		0.00	\$ 20.00		0.000	
CORD WOOD/FUELWOOD			\$8.00	\$20.00		\$12.00	0.00		\$ 8.00		0.000

* STUMPAGE VALUE = % RATING X RANGE DIFFERENCE + LOW RANGE VALUE

CERTIFICATION OF YIELD TAXES ASSESSED
INTENT FILED DURING TAX YEAR: April 1, 2021 to March 31, 2022

TOWN / CITY OF: HUDSON
 COUNTY OF: HILLSBOROUGH COUNTY
 CERTIFICATION DATE: March 22, 2022

SEND SIGNED COPY TO: DEPT. OF REVENUE ADMINISTRATION
 MUNICIPAL AND PROPERTY DIVISION
 P.O. BOX 487
 CONCORD, NH 03302-0487

 (Selectmen/assessor)

 (Selectmen/assessor)

 (Selectmen/assessor)

 (Selectmen/assessor)

 (Selectmen/assessor)

# 1	# 4	# 5	# 6	# 6	# 7	# 8	# 9	# 10
NAME OF OWNER	SPECIES	NUMBER OF BOARD FEET IN THOUSANDS	NUMBER OF TONS	NUMBER OF CORDS	STUMPAGE VALUE	TOTAL ASSESSED VAL.	TAX AT 10 %	
36 EXECUTIVE OWNER, LLC 7315 WISCONSIN AVE 200W BETHESDA, MD 20814	WHITE PINE	0.000			\$75.00	\$0.00	\$0.00	
	HEMLOCK	0.000			\$15.00	\$0.00	\$0.00	
	RED PINE	0.000			\$10.00	\$0.00	\$0.00	TOTAL TAX
ACCOUNT OR SERIAL #: 3889	SPRUCE & FIR	0.000			\$40.00	\$0.00	\$0.00	DUE ON THIS
	HARD MAPLE	0.000			\$120.00	\$0.00	\$0.00	OPERATION
# 2 BY WHICH LOT WAS DESIGNATED IN NOTICE OF INTENT MAP & LOT NUMBER 215-004-000	WHITE BIRCH	0.000			\$30.00	\$0.00	\$0.00	(TOTAL OF COL. # 9)
	YELLOW BIRCH	0.000			\$50.00	\$0.00	\$0.00	
	OAK	0.000			\$180.00	\$0.00	\$0.00	
	ASH	0.000			\$75.00	\$0.00	\$0.00	
	SOFT MAPLE	0.000			\$50.00	\$0.00	\$0.00	
	BEECH/PALLET/TIE LOGS	0.000			\$20.00	\$0.00	\$0.00	
	OTHERS :	0.000			\$0.00	\$0.00	\$0.00	
	OTHERS :	0.000			\$0.00	\$0.00	\$0.00	
					TONS	CORDS		\$27.46
# 3 OPERATION NUMBER 21-229-02-T	SPRUCE & FIR		0.00		\$ -	\$0.00	\$0.00	
	HARDWOOD & ASPEN		0.00		\$ 0.50	\$0.00	\$0.00	
	PINE		0.00		\$ -	\$0.00	\$0.00	
	HEMLOCK		0.00		\$ -	\$0.00	\$0.00	
	BIOMASS CHIPS		274.60		\$ 1.00	\$274.60	\$27.46	
	HIGH GRADE SPRUCE		0.00		\$ 20.00	\$0.00	\$0.00	
	CORDWOOD			0.00		\$ 8.00	\$0.00	\$0.00
						\$274.60	\$27.46	

**ORIGINAL WARRANT
YIELD TAX LEVY
March 22, 2022
THE STATE OF NEW HAMPSHIRE**

HILLSBOROUGH COUNTY

TO: Roger Ordway Jr., Collector of Taxes for Town of HUDSON, in said county:

In the name of said State you are hereby directed to collect on or before thirty (30) days from date of bill from the person(s) named herewith committed to you, the Yield Tax set against their name(s), amounting in all to the sum of : **\$27.46**, with interest at eighteen (18%) percent per annum from the due date and on all sums not paid on or before that day. We further order you to pay all monies collected to the treasurer of said town, or treasurer's designee as provided in RSA 41:29, VI, at least on a weekly basis, or daily when receipts exceed \$1,500.00 or more often when directed by the Commissioner of Revenue Administration.

Given under our hands and seal at HUDSON

(Selectmen/assessor)

(Selectmen/assessor)

(Selectmen/assessor)

(Selectmen/assessor)

(Selectmen/assessor)

DATE SIGNED: March 22, 2022

NAME & ADDRESS	MAP & LOT	OPERATION #	YIELD TAX DUE
36 EXECUTIVE OWNER, LLC 7315 WISCONSIN AVE 200W BETHESDA, MD 20814	215-004-000	21-229-02-T	\$27.46

TAX DUE DATE: April 21, 2022 TOTAL YIELDTAX: \$27.46

TIMBER CUT FOR INTENTS FILED DURING: April 1, 2021 to March 31, 2022

TOWN OF HUDSON

12 School Street

Hudson, NH 03051
603-886-6003

36 EXECUTIVE OWNER, LLC
.
7315 WISCONSIN AVE 200W
BETHESDA, MD 20814

YIELD TAX ON TIMBER CUT

TAX ACCOUNT & SERIAL I.D. NUMBER: 3889
TAX MAP & LOT NUMBER: 215-004-000
YIELD TAX OPERATION NUMBER: 21-229-02-T
DATE OF YIELD TAX BILL: 3/22/2022
AMOUNT COMMITTED TO ME
FOR COLLECTION PER RSA 79: \$27.46

***** 18% APR INTEREST WILL BE CHARGED AFTER 4/21/2022 ON UNPAID TAXES *****

APPEAL: an owner may, within 90 days of notice of the tax, appeal to the assessing officials in writing for an abatement from the original assessment, but no owner shall be entitled to an abatement unless he has complied with the provisions of RSA 79:10 and 11. (RSA 79:8)

TAX OFFICE HOURS: MONDAY-FRIDAY 8 AM - 4:30 PM

Sincerely,

Roger Ordway, Jr.
Tax Collector

TOWN: HUDSON
 COUNTY: HILLSBOROUGH COUNTY
 OWNER: 36 EXECUTIVE OWNER, LLC
 OWNER: .
 ADDRESS: 7315 WISCONSIN AVE 200W
 ADDRESS: BETHESDA, MD 20814

INTENT FILED DURING TAX YEAR: April 1, 2021 to March 31, 2022

ACCOUNT & SERIAL #: 3889
 MAP & LOT #: 215-004-000
 OPERATION #: 21-229-02-T
 DATE OF BILLING: March 22, 2022

SPECIES	LOW MBF	HIGH MBF			RANGE DIFFERENCE		RATING %	STUMPAGE VALUE *	# BOARD FEET IN THOUSANDS		
WHITE PINE	\$75.00	\$200.00				\$125.00	0.00	\$ 75.00	0.000		
HEMLOCK	\$15.00	\$75.00				\$60.00	0.00	\$ 15.00	0.000		
RED PINE	\$10.00	\$60.00				\$50.00	0.00	\$ 10.00	0.000		
SPRUCE & FIR	\$40.00	\$160.00				\$120.00	0.00	\$ 40.00	0.000		
HARD MAPLE	\$120.00	\$400.00				\$280.00	0.00	\$ 120.00	0.000		
WHITE BIRCH	\$30.00	\$100.00				\$70.00	0.00	\$ 30.00	0.000		
YELLOW BIRCH	\$50.00	\$250.00				\$200.00	0.00	\$ 50.00	0.000		
OAK	\$180.00	\$425.00				\$245.00	0.00	\$ 180.00	0.000		
ASH	\$75.00	\$250.00				\$175.00	0.00	\$ 75.00	0.000		
SOFT MAPLE	\$50.00	\$175.00				\$125.00	0.00	\$ 50.00	0.000		
BEECH/PALLET/TIE LOGS	\$20.00	\$85.00				\$65.00	0.00	\$ 20.00	0.000		
OTHERS:	\$0.00	\$0.00				\$0.00	0.00	\$ -	0.000		
OTHERS:	\$0.00	\$0.00				\$0.00	0.00	\$ -	0.000		
TONS & CORDS	TONS LOW	TONS HIGH	CORDS LOW	CORDS HIGH	TONS	CORDS	RATING %	STUMPAGE VALUE TONS *	STUMPAGE VALUE CORDS *	#TONS	#CORDS
SPRUCE & FIR	\$0.00	\$1.00			\$1.00		0.00	\$ -		0.000	
HARDWOOD & ASPEN	\$0.50	\$5.00			\$4.50		0.00	\$ 0.50		0.000	
PINE	\$0.00	\$1.00			\$1.00		0.00	\$ -		0.000	
HEMLOCK	\$0.00	\$5.00			\$5.00		0.00	\$ -		0.000	
BIOMASS CHIPS	\$0.00	\$1.00			\$1.00		1.00	\$ 1.00		274.600	
HIGH GRADE SPRUCE	\$20.00	\$30.00			\$10.00		0.00	\$ 20.00		0.000	
CORD WOOD/FUELWOOD			\$8.00	\$20.00		\$12.00	0.00		\$ 8.00		0.000

* STUMPAGE VALUE = % RATING X RANGE DIFFERENCE + LOW RANGE VALUE

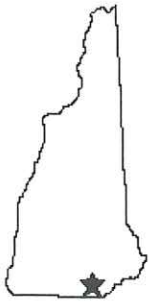

TOWN OF HUDSON

Office of the Assessor

Jim Michaud
Chief Assessor, CAE
email: jmichaud@hudsonnh.gov

www.hudsonnh.gov



Agenda 3-22-22

12 School Street · Hudson, New Hampshire 03051 · Tel: 603-886-6009 · Fax: 603-598-6481

6A-4

TO: Board of Selectmen
Steve Malizia, Town Administrator

DATE: March 22, 2022

FROM: Jim Michaud, Chief Assessor 

RE: All Veterans Tax Credit:

8A Shelley Dr. – map 204/ lot 049/ sub 001



I recommend the Board of Selectmen sign the PA-29 form granting an All Veterans Tax Credit to the property owner listed below. The resident has provided a copy of their DD-214 verifying that they qualify for the credit.

Patrick Kilduff - 8A Shelley Dr. – map 204/ lot 049/ sub 001

MOTION: Motion to grant an All Veterans Tax Credit to the property owner referenced in the above request.

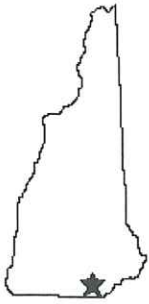

TOWN OF HUDSON

Office of the Assessor

Jim Michaud
Chief Assessor, CAE
email: jmichaud@hudsonnh.gov

www.hudsonnh.gov



Agenda
3.22.22

12 School Street · Hudson, New Hampshire 03051 · Tel: 603-886-6009 · Fax: 603-598-6481

6A-5

TO: Board of Selectmen
Steve Malizia, Town Administrator

DATE: March 22, 2022

FROM: Jim Michaud, Chief Assessor *JM*

RE: Veteran Tax Credits:

18A Chagnon Ln. – map 116/ lot 013/ sub 001
16A Chandler Ct. – map 177/ lot 005/ sub 152



I recommend the Board of Selectmen sign the PA-29 forms granting a Veteran Tax Credit to the property owners listed below. The residents have provided a copy of their DD-214 verifying that they qualify for the credit.

Matthew Clancy - 18A Chagnon Ln. – map 116/ lot 013/ sub 001
Connor Abreu - 16A Chandler Ct. – map 177/ lot 005/ sub 152

MOTION: Motion to grant Veteran Tax Credits to the property owners referenced in the above request.



TOWN OF HUDSON

Office of the Assessor

Jim Michaud
Chief Assessor, CAE
email: jmichaud@hudsonnh.gov

www.hudsonnh.gov



Agenda
3-22-22

12 School Street · Hudson, New Hampshire 03051 · Tel: 603-886-6009 · Fax: 603-598-6481

6A-6

TO: Board of Selectmen
Steve Malizia, Town Administrator

DATE: March 22, 2022

FROM: Jim Michaud, Chief Assessor *[Signature]*

RE: Disabled Veteran Tax Credits:

58 Brackett Ln. – map 156/ lot 005/ sub 036
13A Rangers Dr. – map 151/ lot 027/ sub 001

RECEIVED

MAR 17 2022

TOWN OF HUDSON
SELECTMEN'S OFFICE

I recommend the Board of Selectmen sign the PA-29 forms granting Disabled Veteran Tax Credits to the property owners listed below. The residents have provided documentation verifying that they do qualify for this credit.

Patricia Murphy - 58 Brackett Ln. – map 156/ lot 005/ sub 036
Eric Clifford - 13A Rangers Dr. – map 151/ lot 027/ sub 001

Note: The State Legislature has determined that a veteran receiving an All Veterans Tax Credit cannot also receive a Disabled Veteran Tax Credit so Mr. Clifford has decided to forego his All Veterans Tax Credit for the higher amount of the Disabled Vet Credit.

MOTION: Motion to grant Disabled Veteran Tax Credits to the property owners referenced in the above request.



TOWN OF HUDSON
Office of the Assessor



Agenda 3.22.22

Jim Michaud
Chief Assessor, CAE
email: jmichaud@hudsonnh.gov

www.hudsonnh.gov

12 School Street · Hudson, New Hampshire 03051 · Tel: 603-886-6009 · Fax: 603-598-6481

6A-7

TO: Board of Selectmen
Steve Malizia, Town Administrator

DATE: March 22, 2022

FROM: Jim Michaud, Chief Assessor 

RE: Elderly Exemption:
7 Porter Ave. – map 190/ lot 070

RECEIVED

MAR 17 2022

TOWN OF HUDSON
SELECTMENS OFFICE

I recommend the Board of Selectmen sign the PA-29 form granting an Elderly Exemption to the property owner listed below. The resident has provided the proper documentation to show they qualify for this exemption.

David Delbove - 7 Porter Ave. – map 190/ lot 070

MOTION: Motion to grant an Elderly Exemption to the property owner referenced in the above request.

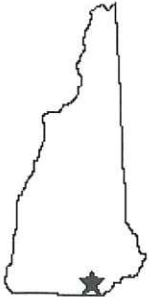

TOWN OF HUDSON

Office of the Assessor

Jim Michaud
Chief Assessor, CAE
email: jmichaud@hudsonnh.gov

www.hudsonnh.gov



Agenda 3/22/22

12 School Street · Hudson, New Hampshire 03051 · Tel: 603-886-6009 · Fax: 603-598-6481

6A-8

TO: Board of Selectmen
Steve Malizia, Town Administrator

DATE: March 22, 2022

FROM: Jim Michaud, Chief Assessor 

RE: Solar Exemption:

37 James Way – map 230/ lot 022/ sub 019

RECEIVED

MAR 17 2022

TOWN OF HUDSON
SELECTMEN'S OFFICE

I recommend the Board of Selectmen sign the PA-29 form granting a Solar Exemption to the property owner listed below. The Assessing Department has verified that the property owner has solar panels.

Robert and Helene Wherry - 37 James Way – map 230/ lot 022/ sub 019

MOTION: Motion to grant a Solar Exemption to the property owners referenced in the above request.

Agenda
3-22-22

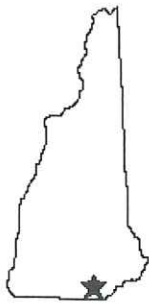

TOWN OF HUDSON

Office of the Assessor



Jim Michaud
Chief Assessor, CAE
email: jmichaud@hudsonnh.gov

www.hudsonnh.gov

12 School Street · Hudson, New Hampshire 03051 · Tel: 603-886-6009 · Fax: 603-598-6481

6A-9

TO: Board of Selectmen
Steve Malizia, Town Administrator

March 10, 2022

FROM: Jim Michaud, Chief Assessor 

RECEIVED

MAR 17 2022

TOWN OF HUDSON
SELECTMEN'S OFFICE

RE: Tax Warrant for 50 Mobile Drive (Tax Map 178 Lot 13-47)
Tax Deferral conversion

I recommend that the Board of Selectmen sign the attached "Tax Warrant" authorizing the tax collector's office to warrant the amount due on the attached. The property is the subject of a tax deferral (RSA 72:38-a) wherein the owner of the property has passed away and the "heirs" have not redeemed the property by paying off the tax deferral within 9 months of the owners death. The Town ran into this same situation in 2015 on a different property and the advice at the time from Attorney LeFevre is the same as I am recommending here, this is the proper course of action given the circumstances. Please advise if the BOS have any concerns.

Draft Motion: Motion to sign the Tax Warrant for Tax Map 178 Lot 13-47, 50 Mobile Drive, as recommended by the Chief Assessor

**THE STATE OF NEW HAMPSHIRE
TOWN OF HUDSON**

Board of Selectmen
Hudson, NH

**TAX WARRANT
RSA § 72:38-a, IV**

To Roger Ordway Jr., Tax Collector, Town of Hudson, County of Hillsborough, State of New Hampshire:

Upon default of redemption by the heirs, heirs-at-law, assignees, or devisees of Artie R. Glenn, of real estate taxes deferred by said Artie R. Glenn pursuant to RSA § 72:38-a, the Board of Selectmen hereby commit the accrued amount of the deferred real estate taxes, together with the interest thereon, in the present amount of \$4,441.40 to you, pursuant to RSA § 72:38-a, IV, for collection, in accordance with RSA § 76:13 and RSA 80.

On this 22nd day of March, 2022, by the Board of Selectmen, Town of Hudson, County of Hillsborough, State of New Hampshire.

Marilyn E. McGrath, Chairman

Robert Guessferd, Vice-Chairman

David S. Morin

Kara Roy

Brett Gagnon

Town of Hudson, NH
Summary of Debts to the Town by:
Estate of Artie Glenn
As of: March 22, 2022

	Years	Principle	Interest	Total
Elderly/Disabled Tax Deferral	2016 - 2018	\$ 3,869.92	\$ 571.48	\$ 4,441.40 ✓
Welfare Assistance	2018 - 2019	\$ 5,672.24	\$ 711.58	\$ 6,383.82
Sewer - Not on Town		0.00	0.00	0.00
Water - Not on Town		0.00	0.00	0.00
	Totals	\$ 9,542.16	\$ 1,283.06	\$ 10,825.22

Prepared by: L. Labrie
Wednesday, March 9, 2022

72:38-a Tax Deferral for Elderly and Disabled. –

I. Any resident property owner may apply for a tax deferral if the person:

(a) Is either at least 65 years old or eligible under Title II or Title XVI of the federal Social Security Act for benefits for the disabled; and

(b) Has owned the homestead for at least 5 consecutive years if the person qualifies as an elderly applicant, or has owned the homestead for at least one year if the person qualifies as a disabled applicant; and

(c) Is living in the home.

The assessing officials may annually grant a person qualified under this paragraph a tax deferral for all or part of the taxes due, plus annual interest at 5 percent, if in their opinion the tax liability causes the taxpayer an undue hardship or possible loss of the property. The total of tax deferrals on a particular property shall not be more than 85 percent of its equity value. The total of tax deferrals shall be determined by the following formula:

Assessed Value = Equalized Assessed Value

Equalization Ratio

Equalized Assessed Value - Total of Priority Liens = Equity Value

Equity Value X .85 = Total Amount Which May be Deferred

At any time during the tax deferral process, the governing body may consider an abatement pursuant to RSA 76:16.

II. A tax deferral shall be subject to any prior liens on the property and shall be treated as such in any foreclosure proceeding.

II-a. No person shall be entitled to the deferral under this section unless the person has filed with the selectmen or assessors, by March 1 following the date of notice of tax under RSA 72:1-d, a permanent application therefor, signed under penalty of perjury, on a form approved and provided by the commissioner of revenue administration, showing that the applicant is the true and lawful owner of the property on which the deferral is claimed and that the applicant is duly qualified at the time of application. Any person who changes residence after filing such a permanent application shall file an amended permanent application on or before December 1 immediately following the change of residence. The filing of the permanent application shall be sufficient for said persons to receive a deferral on an annual basis so long as the applicant does not change residence; provided, however, that towns and cities may require an annual application for the tax deferral authorized for the elderly and disabled by this section. The form shall include the following and such other information deemed necessary by the commissioner:

(a) Instructions on completing and filing the form, including an explanation of the grounds for requesting a deferral.

(b) Sections for information concerning the applicant, the property for which the relief is sought, and other properties owned by the person applying.

(c) A section explaining the appeal procedure and stating the appeal deadline in the event the municipality denies the tax relief request in whole or in part.

(d) A place for the applicant's signature with a certification by the person applying that the application has a good faith basis and the facts in the application are true.

III. If the property is subject to a mortgage, the owner must have the mortgage holder's approval of the tax deferral. Such approval does not grant the town a preferential lien.

IV. When the owner of a property subject to a tax deferral dies, the heirs, heirs-at-law, assignee, or devisee shall have first priority to redeem the estate by paying in full the deferred taxes plus any interest due. If the heirs, heirs-at-law, assignees, or devisees do not redeem the property

within 9 months of the date of death of the property owner, the municipality may commit the accrued amount of the deferral to the collector of taxes with a warrant signed by the assessing officials requiring him or her to collect it; and the collector of taxes shall have the same rights and remedies in relation thereto as provided in RSA 76:13 and RSA 80. Prior to holding a tax sale or executing a priority tax lien under RSA 80:59, the collector shall, at least 30 days prior to such tax sale or tax lien execution, send notice by certified or registered mail, to the last known post office address of the current owner, if known, or to the last known address of the deceased taxpayer, and to all mortgagees from whom permission has been sought pursuant to paragraph III of this section. Any person with a legal interest in the property may redeem it, either prior to the tax sale or tax lien execution, or subsequently as set forth in RSA 80:32 or RSA 80:69.

IV-a. When the owner of a property subject to a tax deferral sells or otherwise conveys the property, the owner or grantee shall pay in full the deferred taxes plus any interest due and the municipality shall provide recorded written release or satisfaction of the notice of tax deferral. If the owner or grantee, who shall be deemed to have notice of and shall take title to the property subject to the notice of tax deferral, does not pay the accrued amount on the property within 9 months of the date of sale or conveyance of the property, the municipality may commit the accrued amount of the deferral to the collector of taxes with a warrant signed by the assessing officials requiring him or her to collect it; and the collector of taxes shall have the same rights and remedies in relation thereto as provided in RSA 76:13 and RSA 80. Prior to holding a tax sale or executing a priority tax lien under RSA 80:59, the collector shall, at least 30 days prior to such tax sale or tax lien execution, send notice by certified or registered mail, to the last known post office address of the current owner, if known, or to the last known address of the taxpayer who received the deferral, and to all mortgagees from whom permission has been sought pursuant to paragraph III of this section. Any person with a legal interest in the property may redeem it, either prior to the tax sale or tax lien execution, or subsequently as set forth in RSA 80:32 or RSA 80:69.

V. The assessing officials shall file notice of each tax deferral granted, within 30 days, with the registry of deeds of the county in which the property is located to perfect it.

VI. When a taxpayer appeals the denial of a deferral application to the superior court or board of tax and land appeals, the court or board may reverse or affirm, wholly or partly, or may modify the decision brought up for review when there is an error of law or when the court or board is persuaded by the balance of probabilities, on the evidence before it, that said decision is unreasonable.

Source. 1973, 452:1. 1975, 214:1. 1977, 54:1; 591:1-3. 1981, 374:1. 1983, 155:3. 1994, 390:1. 1995, 265:7. 1997, 37:1. 2003, 299:12, eff. April 1, 2003; 299:13, eff. April 1, 2005. 2013, 141:1, eff. Jan. 1, 2014.



TAG DAY SALES

Hudson, NH

6B-1

RSA 31:91

Soliciting Funds

The right to grant permits for soliciting funds for charitable purposes and for the sale of tags, flowers or other objects for charitable purposes shall be vested in the mayor, aldermen of a city or the selectmen of towns.

Instructions to obtain Tag Day Permit:

1. **Submit a letter to the Board of Selectmen** at 12 School Street, Hudson, NH 03051, stating the date, time and location that the collection of funds will take place (or fax to 603-598-6481).
2. **Indicate how the collected funds will be used/distributed** or to whom it will benefit or to whom the funds will be collected on behalf of.
3. **Include verification of being properly registered** with the NH Attorney General's Office, Division of Charitable Trusts, unless exempt, i.e., governmental subdivisions or religious organizations, who shall provide verification they are the bona fide representative of an exempt entity (RSA 7:19, ct scq).
4. **Include name, address, phone number and e-mail** of a contact person in case there are questions, concerns or if additional information is required.
5. **Include a signed letter of permission** from the establishment where the collection of funds will take place.

.....
For Office Use Only

Organization American Legion Post 247

_____ Approved _____ Denied by Board of Selectmen on _____

If denied, reason _____

Chairman, Board of Selectmen



American Legion
Post 247
Tyngsboro, MA 01879

RECEIVED

MAR 11 2022

TOWN OF HUDSON
SELECTMEN'S OFFICE

March 11, 2022

Board of Selectmen
Hudson Town Hall
12 School Street, Suite 2
Hudson, NH 03051

To Whom It May Concern:

I represent the American Legion, Post 247, in Tyngsborough, MA. Sam's Club has recently approved our organization to run fund raising events on the following dates:

July 9th and July 10th, 2022

Our mission is to provide meals to veterans from the Bedford VA Hospital and other local veteran facilities on a monthly basis. We are seeking your permission to run these fund raisers outside of Sam's Club. The money that we raise will allow our Post to continue to feed our veterans. Attached please find documentation from Sam's Club approving our organization to run these events.

Please feel free to contact me should you require any additional information. I can be reached at 978-551-1344.

Thank you for your consideration.

Sincerely,

David Coles
David Coles

*our new
Charitable
organization list*
3-11-22



Sam's Club #6352
7 Wal-mart Blvd
Hudson, NH 03051
(603) 882 - 4600

To whom it may concern,

The following organization has been approved by Sam's Club to run a fund raising event outside the store:

Organization: Tyngsboro American Legion, Post 247
Contact Name: David Coles
Contact Phone: 978 551 1344
Event Date(s): July 9 & 10th 2022

If there are any questions, please contact the Marketing Team at Sam's Club # 6352.

Thank you,

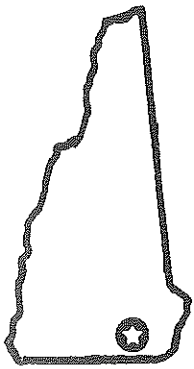

TOWN OF HUDSON
Office of the Town Administrator
12 School Street
Hudson, New Hampshire 03051



Stephen A. Malizia, Town Administrator – smalizia@hudsonnh.gov – Tel: 603-886-6024 Fax: 603-598-6481

6B-2

To: Board of Selectmen

From: Steve Malizia, Town Administrator

Date: March 11, 2022

Re: Hudson Speedway 2022 Permit

Attached please find a License to Operate a Motor Vehicle Race Track for the Hudson Speedway. The premises have been inspected and the Inspectional Services Division and the Police Chief have provided a list of conditions that must be met by the applicant. . In addition, a second license for the Hudson Heroes Driving School has been prepared separate from the regular Speedway license. Should the Board of Selectmen vote to approve the licenses, the following motion is appropriate:

Motion: To approve the Hudson Speedway License to Operate a Motor Vehicle Race Track for the 2022 racing season and for the Hudson Heroes Driving School with the conditions required by the Police Chief and the Inspectional Services Division.

Should you have any questions or need additional information, please feel free to contact me. Thank you.

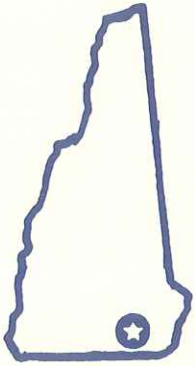

TOWN OF HUDSON

Board of Selectmen

12 School Street Hudson, New Hampshire 03051 603/886-6024 FAX 603/598-6481



2022 HUDSON SPEEDWAY LICENSE

Date: March 23, 2022

This is to acknowledge that I have received the license issued by the Town of Hudson, which was approved by the Board of Selectmen on March 22, 2022, along with Town of Hudson Ordinance No. 115 as enacted April 8, 1983 and Town Meeting Article No. 24 as adopted March 18, 1985, and that Hudson Speedway will abide by the provisions outlined therein and in accordance with attached staff comments.

Hudson Speedway's mailing address is:

40 Temple Street
Nashua, NH 03060

and the name(s) and phone number at which an official or representative of Hudson Speedway can be contacted are:

Ben Bosowski - Work - 882-2702
- Cell - 233-1328
Email – bosowskiracing@gmail.com

HUDSON SPEEDWAY

By _____
Ben Bosowski
Bosowski Racing LLC

cc: Land Use
Police
Fire

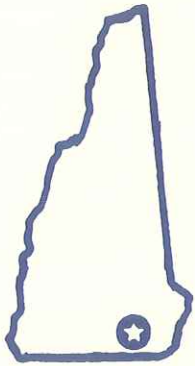

TOWN OF HUDSON

Board of Selectmen

12 School Street Hudson, New Hampshire 03051 603/886-6024 FAX 603/598-6481



LICENSE TO OPERATE A MOTOR VEHICLE RACE TRACK

A license to conduct motor vehicle racing at the Hudson Speedway during the months of May, June, July, August, September and October, 2022 is hereby granted SUBJECT TO ALL PROVISIONS OF ORDINANCE NO. 115, MOTOR VEHICLE RACE TRACK ORDINANCE, adopted on March 26, 1983 by the 1983 Annual Town Meeting, and Article 24 as adopted at the March 1985 Town Meeting and SUBJECT to any revisions or amendments to ordinances as hereinafter enacted.

Dates and hours of operation (and no others) have been approved as follows:

April 3, 10, 17, 24	12:00 Noon - 5:45 PM
May 1, 8, 15, 22, 29, 30 (Monday Holiday)	12:00 Noon - 5:45 PM
June 5, 12	12:00 Noon - 5:45 PM
June 19, 26	4:00 PM - 10:00 PM
July 3, 4, 10, 17, 24, 31	4:00 PM - 10:00 PM
August 7, 14, 21	4:00 PM - 10:00 PM
August 28	12:00 Noon - 5:45 PM
September 4, 5 (Monday Holiday), 11, 18, 25	12:00 Noon - 5:45 PM
October 2, 9, 10 (Monday Holiday), 16, 23, 30	12:00 Noon - 5:45 PM

Approved at meeting of Board of Selectmen on: March 22, 2022

Date: _____

Chairman
Hudson Board of Selectmen

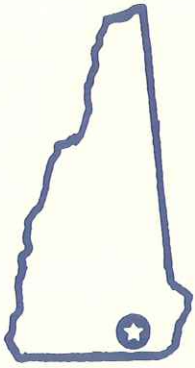

TOWN OF HUDSON

Board of Selectmen

12 School Street Hudson, New Hampshire 03051 603/886-6024 FAX 603/598-6481



LICENSE TO OPERATE A MOTOR VEHICLE RACE TRACK

A license to conduct Hudson Heroes Driving School at the Hudson Speedway during the months of May, June, July, August and September 2022 is hereby granted SUBJECT TO ALL PROVISIONS OF ORDINANCE NO. 115, MOTOR VEHICLE RACE TRACK ORDINANCE, adopted on March 26, 1983 by the 1983 Annual Town Meeting, and Article 24 as adopted at the March 1985 Town Meeting and SUBJECT to any revisions or amendments to ordinances as hereinafter enacted.

Dates and hours of operation (and no others) have been approved as follows:

May 12, 26	3:00 PM – 7:30 PM
June 19, 23	3:00 PM – 7:30 PM
July 7, 21	3:00 PM – 7:30 PM
August 4, 18	3:00 PM – 7:30 PM
September 1, 15	3:00 PM – 7:30 PM

Approved at meeting of Board of Selectmen on: March 22, 2022

Date: _____

Chairman
Hudson Board of Selectmen



40 Temple Street
Nashua, NH 03060
(603)882-2702
bosowskiracing@gmail.com

January 14, 2022

To: Town of Hudson – Board of Selectmen

RE: 2022 Motor Vehicle Race Track License

To Whom it May Concern,

I hereby submit this application for my 2022 license to conduct races at Hudson Speedway. All races will be conducted in accordance with all applicable laws and ordinances. The following race schedule of dates and times are requested;

April 3, 10, 17 & 24	12:00 Noon – 5:45PM
May 1, 8, 15, 22, 29 & 30	12:00 Noon – 5:45PM
June 5 & 12	12:00 Noon – 5:45PM
June 19 & 26	4:00PM – 10:00PM
July 3, 4, 10, 17, 24 & 31	4:00PM – 10:00PM
August 7, 14, 21 & 28	4:00PM - 10:00PM
August 28,	12:00 Noon - 5:45PM
September 4, 5, 11, 18 & 25	12:00 Noon – 5:45PM
October 2, 9, 10, 16, 23, 30 & 31	12:00 Noon – 5:45PM

If you have any questions, please contact me at your earliest convenience at (603)882-2702 or e-mail me at bosowskiracing@gmail.com.

Respectfully Submitted,

Benjamin Bosowski
Owner – Bosowski Racing, LLC

**Hudson Hero's Driving School
40 Temple Street
Nashua, NH 03060
(603)882-2702
bosowskiracing@gmail.com**

January 11, 2022

To: Town of Hudson – Board of Selectmen

RE: 2022 Motor Vehicle Race Track License

To Whom it May Concern,

I hereby submit this application for my 2022 license to conduct races and classes for the Hudson Hero's at Hudson Speedway. All classes will be conducted in accordance with all applicable laws and ordinances. The following schedule of dates and times are requested;

3pm-7:30pm Class time

May 5	Series Introductions and Car Inspections
May 12	Test cars on track
May 19	Rain Date
May 26	School
June 2	Rain Date
June 9	School
June 16	Rain Date
June 23	School
June 30	Rain Date
July 7	School
July 14	Rain Date
July 21	School
July 28	Rain Date
August 4	School
August 11	Rain Date
August 18	School
August 25	Rain Date
September 1	School
September 15	School

If you have any questions, please contact me at your earliest convenience at (603)882-2702 or e-mail me at bosowskiracing@gmail.com.

Respectfully Submitted,

Benjamin Bosowski
Owner – Bosowski Racing, LLC



TOWN OF HUDSON

Police Department

Partners with the Community

1 Constitution Drive, Hudson, New Hampshire 03051
Voice/TTY (603) 886-6011/Crime Line (603) 594-1150/Fax (603) 594-1162



*Tad K. Dionne
Chief of Police*

RECEIVED

MAR 10 2022

TOWN OF HUDSON
SELECTMEN'S OFFICE

*Captain David A. Cayot
Special Investigations Bureau*

*Captain David A. Bianchi
Administrative Bureau*

*Captain Michael P. Davis
Operations Bureau*

To: The Board of Selectmen
Steve Malizia, Town Administrator

From: Tad Dionne, Chief of Police 

Date: 08 March 2022

Re: Hudson Speedway / License

The Police Department is requesting the following conditions be met in accordance to Hudson Town Code, Chapter 264 regarding the Hudson Speedway filing for a Motor Vehicle Race Track License to operate in 2022:

1. All race vehicles will be equipped with mufflers or noise reduction devices.
2. No night time racing while Hudson Public Schools are open and strict adherence to concluding afternoon races at 5:45 PM and evening races at 10:00 PM.
3. Owners of the racetrack will ensure that patrons are advised, via signs and announcements, of no parking on Old Derry Road, Robinson Road and Cutler Road. As well as urge patrons and race teams to depart the Hudson Speedway via Robinson Road to Rt 102 at the conclusion of races.
4. A minimum of two (2) police officers will be assigned to the racetrack and paid by the owners of the Hudson Speedway. The officers will be required to work one half-hour prior to beginning the race, to inspect for alcoholic beverages. If Hudson Police Officers are unable to fill the detail, we will offer the detail to Mutual Aid outside agencies.

Should you have any questions or concerns, please contact me.



A NATIONALLY ACCREDITED LAW ENFORCEMENT AGENCY



TOWN OF HUDSON

FIRE DEPARTMENT

39 FERRY STREET, HUDSON, NEW HAMPSHIRE 03051



TO: Steve Malizia
Town Administrator

FR: Robert M. Buxton *RMB*
Fire Chief

DT: February 28, 2022

RE: Hudson Speedway

Please be advised that the yearly inspection of Hudson Speedway located at 120 Old Derry Road has been completed. There were no violations found and the property remains in good standing.



TOWN OF HUDSON

FIRE DEPARTMENT

INSPECTIONAL SERVICES DIVISION



12 SCHOOL STREET, HUDSON, NEW HAMPSHIRE 03051

Emergency 911
Business 603-886-6005
Fax 603-594-1142

Robert M. Buxton
Chief of Department

February 25, 2022

Re: 120 Old Derry Rd. Hudson Speedway

Chief,

Inspectional Services conducted a place of assembly inspection February 21, 2022 in preparation for the upcoming 2022 racing season. No violations were found or noted. One additional inspection will be scheduled and performed prior to the start of the season.

The inspection history from previous years has gone very well with no violations or complaints.

Sincerely,

David Hebert
Fire Marshal



BOSORAC-01

DOYLES

CERTIFICATE OF LIABILITY INSURANCE

DATE (MM/DD/YYYY)
3/14/2022

THIS CERTIFICATE IS ISSUED AS A MATTER OF INFORMATION ONLY AND CONFERS NO RIGHTS UPON THE CERTIFICATE HOLDER. THIS CERTIFICATE DOES NOT AFFIRMATIVELY OR NEGATIVELY AMEND, EXTEND OR ALTER THE COVERAGE AFFORDED BY THE POLICIES BELOW. THIS CERTIFICATE OF INSURANCE DOES NOT CONSTITUTE A CONTRACT BETWEEN THE ISSUING INSURER(S), AUTHORIZED REPRESENTATIVE OR PRODUCER, AND THE CERTIFICATE HOLDER.

IMPORTANT: If the certificate holder is an ADDITIONAL INSURED, the policy(ies) must have ADDITIONAL INSURED provisions or be endorsed. If SUBROGATION IS WAIVED, subject to the terms and conditions of the policy, certain policies may require an endorsement. A statement on this certificate does not confer rights to the certificate holder in lieu of such endorsement(s).

PRODUCER Insurance Office of America, Inc. 1855 West State Road 434 Longwood, FL 32750	CONTACT NAME: Shelley Doyle	PHONE (A/C, No, Ext): (407) 998-4911 14911	FAX (A/C, No): (321) 214-6402
	E-MAIL ADDRESS: Shelley.Doyle@ioausa.com		
INSURED Bosowski Racing LLC 40 Temple Street Nashua, NH 03060	INSURER(S) AFFORDING COVERAGE		NAIC #
	INSURER A : New York Marine & General Insurance Company		16608
	INSURER B : Federal Insurance Company		20281
	INSURER C :		
	INSURER D :		
	INSURER E :		

COVERAGES **CERTIFICATE NUMBER:** **REVISION NUMBER:**

THIS IS TO CERTIFY THAT THE POLICIES OF INSURANCE LISTED BELOW HAVE BEEN ISSUED TO THE INSURED NAMED ABOVE FOR THE POLICY PERIOD INDICATED. NOTWITHSTANDING ANY REQUIREMENT, TERM OR CONDITION OF ANY CONTRACT OR OTHER DOCUMENT WITH RESPECT TO WHICH THIS CERTIFICATE MAY BE ISSUED OR MAY PERTAIN, THE INSURANCE AFFORDED BY THE POLICIES DESCRIBED HEREIN IS SUBJECT TO ALL THE TERMS, EXCLUSIONS AND CONDITIONS OF SUCH POLICIES. LIMITS SHOWN MAY HAVE BEEN REDUCED BY PAID CLAIMS.

INSR LTR	TYPE OF INSURANCE	ADDL INSD	SUBR WVD	POLICY NUMBER	POLICY EFF (MM/DD/YYYY)	POLICY EXP (MM/DD/YYYY)	LIMITS	
A	<input checked="" type="checkbox"/> COMMERCIAL GENERAL LIABILITY	X		GL202000014046-122	4/5/2021	4/5/2022	EACH OCCURRENCE	\$ 1,000,000
	<input type="checkbox"/> CLAIMS-MADE <input checked="" type="checkbox"/> OCCUR						DAMAGE TO RENTED PREMISES (Ea occurrence)	\$ 300,000
	<input checked="" type="checkbox"/> Motorsports liability						MED EXP (Any one person)	\$
	GEN'L AGGREGATE LIMIT APPLIES PER:						PERSONAL & ADV INJURY	\$ 1,000,000
	<input checked="" type="checkbox"/> POLICY <input type="checkbox"/> PROJECT <input type="checkbox"/> LOC						GENERAL AGGREGATE	\$ 5,000,000
	OTHER:						PRODUCTS - COMP/OP AGG	\$ 5,000,000
	AUTOMOBILE LIABILITY						PARTICIPANT LEG	\$ 1,000,000
	<input type="checkbox"/> ANY AUTO OWNED AUTOS ONLY						COMBINED SINGLE LIMIT (Ea accident)	\$
	<input type="checkbox"/> SCHEDULED AUTOS						BODILY INJURY (Per person)	\$
	<input type="checkbox"/> HIRED AUTOS ONLY						BODILY INJURY (Per accident)	\$
	<input type="checkbox"/> NON-OWNED AUTOS ONLY						PROPERTY DAMAGE (Per accident)	\$
								\$
A	<input type="checkbox"/> UMBRELLA LIAB			EX202000001718-156	4/5/2021	4/5/2022	EACH OCCURRENCE	\$ 1,000,000
	<input checked="" type="checkbox"/> EXCESS LIAB						AGGREGATE	\$ 1,000,000
	DED <input type="checkbox"/> RETENTION \$							\$ 1,000,000
	WORKERS COMPENSATION AND EMPLOYERS' LIABILITY						PER STATUTE	OTH-ER
	ANY PROPRIETOR/PARTNER/EXECUTIVE OFFICER/MEMBER EXCLUDED? (Mandatory in NH)		Y / N				E.L. EACH ACCIDENT	\$
	If yes, describe under DESCRIPTION OF OPERATIONS below		N / A				E.L. DISEASE - EA EMPLOYEE	\$
B	Excess Medical			9908-3595	4/5/2021	4/5/2022	E.L. DISEASE - POLICY LIMIT	\$ 50,000

DESCRIPTION OF OPERATIONS / LOCATIONS / VEHICLES (ACORD 101, Additional Remarks Schedule, may be attached if more space is required)
Hudson Speedway - 120 Old Derry Rd, Hudson, NH
Certificate holder listed is included as additional insured as respects to liability claims arising out of the negligence/ operations of the Named insured.

CERTIFICATE HOLDER Town of Hudson New Hampshire Attn: Steve Maizia 12 School Street Hudson, NH 03051	CANCELLATION SHOULD ANY OF THE ABOVE DESCRIBED POLICIES BE CANCELLED BEFORE THE EXPIRATION DATE THEREOF, NOTICE WILL BE DELIVERED IN ACCORDANCE WITH THE POLICY PROVISIONS.
	AUTHORIZED REPRESENTATIVE 

HUDSON, NH SCHOOL DISTRICT 2021-2022 CALENDAR

19, 20 New Teacher Orientation
23 – 25 Teacher Workshop

26 First Day for All Students

4 days

AUGUST 2021						
S	M	T	W	Th	F	S
1	2	3	4	5	6	7
8	9	10	11	12	13	14
15	16	17	18	19	20	21
22	23	24	25	26	27	28
29	30	31				

FEBRUARY 2022						
S	M	T	W	Th	F	S
		1	2	3	4	5
6	7	8	9	10	11	12
13	14	15	16	17	18	19
20	21	22	23	24	25	26
27	28					

FEB 28 – MAR 4 Winter Break

19 days

6 Labor Day (no school)

21 days

SEPTEMBER 2021						
S	M	T	W	Th	F	S
			1	2	3	4
5	6	7	8	9	10	11
12	13	14	15	16	17	18
19	20	21	22	23	24	25
26	27	28	29	30		

MARCH 2022						
S	M	T	W	Th	F	S
		1	2	3	4	5
6	7	8	9	10	11	12
13	14	15	16	17	18	19
20	21	22	23	24	25	26
27	28	29	30	31		

FEB 28 – MAR 4 Winter Break

25 Teacher Workshop (no school)

18 days

8 Teacher Workshop (no school)
11 Columbus Day (no school)

19 days

OCTOBER 2021						
S	M	T	W	Th	F	S
					1	2
3	4	5	6	7	8	9
10	11	12	13	14	15	16
17	18	19	20	21	22	23
24	25	26	27	28	29	30
31						

APRIL 2022						
S	M	T	W	Th	F	S
					1	2
3	4	5	6	7	8	9
10	11	12	13	14	15	16
17	18	19	20	21	22	23
24	25	26	27	28	29	30

25 – 29 Spring Break

16 days

11 Veterans Day (no school)
24 – 26 Thanksgiving Break

18 days

NOVEMBER 2021						
S	M	T	W	Th	F	S
	1	2	3	4	5	6
7	8	9	10	11	12	13
14	15	16	17	18	19	20
21	22	23	24	25	26	27
28	29	30				

MAY 2022						
S	M	T	W	Th	F	S
1	2	3	4	5	6	7
8	9	10	11	12	13	14
15	16	17	18	19	20	21
22	23	24	25	26	27	28
29	30	31				

30 Memorial Day (no school)

21 days

23 – 31 Holiday Break

16 days

DECEMBER 2021						
S	M	T	W	Th	F	S
			1	2	3	4
5	6	7	8	9	10	11
12	13	14	15	16	17	18
19	20	21	22	23	24	25
26	27	28	29	30	31	

JUNE 2022						
S	M	T	W	Th	F	S
			1	2	3	4
5	6	7	8	9	10	11
12	13	14	15	16	17	18
19	20	21	22	23	24	25
26	27	28	29	30		

15 Last Day for Students (tentative)
(early release for students)
16 Teacher Workshop (am only)

NOTE: Last day includes 3 snow days.

11 days

14 Early Release for Students
14 Teacher Workshop PM
17 Martin Luther King/Civil Rights Day (no school)

20 days

JANUARY 2022						
S	M	T	W	Th	F	S
						1
2	3	4	5	6	7	8
9	10	11	12	13	14	15
16	17	18	19	20	21	22
23	24	25	26	27	28	29
30	31					

NOTE: Count below includes 3 snow days.

August thru January: 98 days
February thru June: 85 days

 No school for students or staff

 No school for students (Jan 14 – early release for students, pm workshop for teachers)

HUDSON SCHOOL DISTRICT 2022-2023 CALENDAR

18, 19 New Teacher Orientation
24 – 26 Teacher Workshop
29 First Day for All Students

AUGUST 2022						
S	M	T	W	Th	F	S
	1	2	3	4	5	6
7	8	9	10	11	12	13
14	15	16	17	18	19	20
21	22	23	24	25	26	27
28	29	30	31			

3 days

FEBRUARY 2023						
S	M	T	W	Th	F	S
			1	2	3	4
5	6	7	8	9	10	11
12	13	14	15	16	17	18
19	20	21	22	23	24	25
26	27	28				

FEB 27 – MAR 3 Winter Break

18 days

5 Labor Day (no school)

SEPTEMBER 2022						
S	M	T	W	Th	F	S
				1	2	3
4	5	6	7	8	9	10
11	12	13	14	15	16	17
18	19	20	21	22	23	24
25	26	27	28	29	30	

21 days

MARCH 2023						
S	M	T	W	Th	F	S
			1	2	3	4
5	6	7	8	9	10	11
12	13	14	15	16	17	18
19	20	21	22	23	24	25
26	27	28	29	30	31	

FEB 27 – MAR 3 Winter Break
14 Voting Day (Teacher Workshop,
no school for students)

19 days

10 Columbus Day (no school)

OCTOBER 2022						
S	M	T	W	Th	F	S
						1
2	3	4	5	6	7	8
9	10	11	12	13	14	15
16	17	18	19	20	21	22
23	24	25	26	27	28	29
30	31					

20 days

APRIL 2023						
S	M	T	W	Th	F	S
						1
2	3	4	5	6	7	8
9	10	11	12	13	14	15
16	17	18	19	20	21	22
23	24	25	26	27	28	29
30						

24 – 28 Spring Break

15 days

8 State General (Teacher
Workshop, no school for students)
11 Veterans Day (no school)
23 – 25 Thanksgiving Break

NOVEMBER 2022						
S	M	T	W	Th	F	S
		1	2	3	4	5
6	7	8	9	10	11	12
13	14	15	16	17	18	19
20	21	22	23	24	25	26
27	28	29	30			

17 days

MAY 2023						
S	M	T	W	Th	F	S
	1	2	3	4	5	6
7	8	9	10	11	12	13
14	15	16	17	18	19	20
21	22	23	24	25	26	27
28	29	30	31			

29 Memorial Day (no school)

22 days

26 – JAN 2 Holiday Break

DECEMBER 2022						
S	M	T	W	Th	F	S
				1	2	3
4	5	6	7	8	9	10
11	12	13	14	15	16	17
18	19	20	21	22	23	24
25	26	27	28	29	30	31

17 days

JUNE 2023						
S	M	T	W	Th	F	S
				1	2	3
4	5	6	7	8	9	10
11	12	13	14	15	16	17
18	19	20	21	22	23	24
25	26	27	28	29	30	

19 Last Day for Students
(tentative)
(early release for students)
20 Teacher Workshop (am only)

NOTE: Last day includes 5 snow
days.

13 days

2 New Year's Day (observed)
13 Early Release for Students
13 Teacher Workshop PM
16 Martin Luther King/Civil Rights
Day (no school)

JANUARY 2023						
S	M	T	W	Th	F	S
1	2	3	4	5	6	7
8	9	10	11	12	13	14
15	16	17	18	19	20	21
22	23	24	25	26	27	28
29	30	31				

20 days

NOTE: Count below includes 5 snow days.

August thru January: 98 days

February thru June: 87 days

 No school for students or staff

 No school for students (Jan 13 – early release for students, PM
workshop for teachers)

approved 03/07/2022

Town of Hudson, NH
Tuesday, February 15, 2022

Chapter 264. Racetracks, Motor Vehicle

[HISTORY: Adopted by the Town of Hudson as indicated in article histories. Amendments noted where applicable.]

GENERAL REFERENCES

Alcoholic beverages — See Ch. 158.

Noise — See Ch. 249.

Outdoor gatherings and activities — See Ch. 253.

Vehicles and traffic — See Ch. 317.

Zoning — See Ch. 334.

Article I. Licensing; Rules and Regulations

[Adopted 3-26-1983 ATM, Art. 36; BOS 4-8-1983 by Ord. No. 115]

§ 264-1. Authority.

This article is enacted pursuant to the provisions of RSA 31:41-a.

§ 264-2. Definitions.

For purposes of this article, the terms below are defined as follows:

MOTOR VEHICLE

Any self-propelled vehicle, except tractors, activated by an internal-combustion engine and not operated exclusively on stationary tracks.

PERSON

Any individual, partnership, corporation or other entity proposing to or operating a motor vehicle racetrack.

§ 264-3. License to be obtained; fee.

[Amended 7-26-1988 by Ord. No. O88-3]

Annually, before April 1, any person proposing to operate a motor vehicle racetrack within the Town of Hudson shall obtain a license from the Board of Selectmen.

[1] *Editor's Note: Pursuant to Res. No. R92-71, adopted 6-8-1992, effective 7-1-1992, this section has been revised to replace "Executive Administrator" with "Board of Selectmen." The specific fees set forth in this section were removed at the request of the town. For current fees, see Ch. 205, Fees.*

§ 264-4. Regulations.

[Amended 7-26-1988 by Ord. No. O88-3; 4-8-2014 by Ord. No. 14-02; 9-15-2020]

At any motor vehicle racetrack operated within the Town of Hudson, the following regulations shall apply:

- A. ^[1]The dates and hours of operation shall be:
- (1) Dates. Racing shall be conducted on Sundays and holidays only.
 - (2) The hours. The afternoon races shall be from 12:00 noon to 5:45 p.m., and evening races shall be from 4:00 p.m. to 10:00 p.m.
- [1] *Editor's Note: See also Art. II, Hours of Operation in June, of this chapter.*
- B. Night and evening races are only permitted during the summer season; specifically, after the Hudson public schools (elementary) have closed in June and prior to the date on which they open in September
- C. Every motor vehicle participating in any races sponsored by a motor vehicle racetrack in Hudson will be equipped with mufflers or noise-reduction devices, which shall be approved by the Board of Selectmen.^[2]
- [2] *Editor's Note: Pursuant to Res. No. R92-71, adopted 6-8-1992, effective 7-1-1992, this subsection has been revised to replace "Executive Administrator" with "Board of Selectmen."*
- D. Any person operating a motor vehicle racetrack shall permit Town officials, or their designated representatives, to conduct from time to time, at said person's expense, such noise level tests or readings as may be deemed appropriate and necessary by the Hudson Board of Selectmen.^[3]
- [3] *Editor's Note: Pursuant to Res. No. R92-71, adopted 6-8-1992, effective 7-1-1992, this subsection has been revised to replace "Executive Administrator" with "Board of Selectmen."*

§ 264-5. Restrictions in license.

Any license issued by the Hudson Board of Selectmen pursuant to § 264-3 shall contain the following:

- A. The proposed schedule of racing dates and hours of operation for which the license is requested.
 - B. A requirement that the person operating the motor vehicle racetrack shall make public announcements, during and at the conclusion of a day's racing activities, requesting that spectators and participants observe local speed limits,^[2] refrain from littering and excessive noise and refrain from using streets when prohibited by local ordinance.^[3]
- [2] *Editor's Note: For speed limit provisions, see Ch. 317, Vehicles and Traffic.*
- [3] *Editor's Note: For street use restrictions, see Ch. 317, Vehicles and Traffic.*
- C. A requirement that the person operating the motor vehicle racetrack provide adequate trash receptacles on the premises, that said receptacles be emptied on a regular basis and that the premises constituting the racetrack be maintained in a neat and orderly fashion, including the parking areas, and that all cleanup activities be completed within 24 hours of the conclusion of any day's racing activities.
 - D. A requirement that the racetrack be kept secure from unauthorized entry when not being used.
- [1] *Editor's Note: Pursuant to Res. No. R92-71, adopted 6-8-1992, effective 7-1-1992, this section has been revised to replace "Executive Administrator" with "Board of Selectmen."*

§ 264-6. Inspections.

[Amended 7-26-1988 by Ord. No. O88-3]

The Hudson Board of Selectmen, Building Inspector and Health Officer are authorized to make announced or unannounced inspections of the property to ensure compliance with the requirements of this Article and any license issued hereunder.

[1] *Editor's Note: Pursuant to Res. No. R92-71, adopted 6-8-1992, effective 7-1-1992, this section has been revised to replace "Executive Administrator" with "Board of Selectmen."*

§ 264-7. Insurance.

[Amended 7-26-1988 by Ord. No. O88-3]

Any person operating a motor vehicle racetrack shall be required to provide such insurance as may be deemed necessary and appropriate by the Hudson Board of Selectmen. Certificates of said insurance shall be filed with the Board of Selectmen prior to the commencement of any racing season or meet.

[1] *Editor's Note: Pursuant to Res. No. R92-71, adopted 6-8-1992, effective 7-1-1992, this section has been revised to replace "Executive Administrator" with "Board of Selectmen."*

§ 264-8. Violations and penalties.

[Amended 7-26-1988 by Ord. No. O88-3]

- A. Any violation of the provisions of this Article or of a license issued by the Board of Selectmen hereunder shall be punishable by a fine not to exceed \$100 for each day that said violation exists. Any fines collected hereunder shall be paid into the general fund of the Town of Hudson.
- B. In addition to or instead of monetary fines, the Board of Selectmen is hereby authorized to revoke any permit issued hereunder where a violation of this Article or of a license issued hereunder exists and the same has not been corrected within five days of sending notice of the violation to the person operating the motor vehicle racetrack.

[1] *Editor's Note: Pursuant to Res. No. R92-71, adopted 6-8-1992, effective 7-1-1992, this section has been revised to replace "Executive Administrator" with "Board of Selectmen."*

§ 264-9. Variances.

[Amended 7-26-1988 by Ord. No. O88-3]

The Board of Selectmen is hereby authorized to vary the requirements set forth in § 264-4B and C and the restrictions in § 264-5 if, in the opinion of the Selectmen, a significant hardship exists for the person operating the motor vehicle racetrack and no significant harm will result to the public health, safety and welfare.

[1] *Editor's Note: Pursuant to Res. No. R92-71, adopted 6-8-1992, effective 7-1-1992, this section has been revised to replace "Executive Administrator" with "Board of Selectmen."*

Article II. Hours of Operation in June

[Article 24, voted in the affirmative 3-15-1985 by the Annual Town Meeting, reads as follows: "To see if the Town will vote that, because of seasonal hot weather in the month of June that presents an unnecessary and unhealthy hardship, due to an ordinance which requires daytime racing only from noon to 5:45 p.m. until grammar school closing, the Hudson Speedway be allowed to operate on the first three Sundays of June between 3:00 p.m. and 8:30 p.m. in the daylight hours."]

[1] *Editor's Note: See also § 264-4B and C.*

HUDSON, NH BOARD OF SELECTMEN

Minutes of the February 22, 2022 Meeting

1. CALL TO ORDER - by Chairman McGrath the meeting of February 22, 2022 at 6:59 p.m. in the Selectmen Meeting Room at Town Hall
2. PLEDGE OF ALLEGIANCE led by Hudson resident, James Battis
3. ATTENDANCE

Board of Selectmen: Marilyn McGrath, Bob Guessferd, David Morin, Kara Roy, Brett Gagnon

Staff/Others: Steve Malizia, Town Administrator; Elvis Dhima, Town Engineer; Brian Groth - Town Planner; Bill Collins, Conservation Commission Chairman; Gary Gasdia, School Board Chairman; Jill Laffin, Executive Assistant

4. PUBLIC INPUT

Chairman McGrath started off by saying, Does anyone in the audience wish to address the board on any issue which the board has control of at this time? If you do come on up and give you a name and address, for the record

James Battis, 6 Potter Road

Mr. Battis said, I come before you tonight to state my concerns with the proposed feasibility study for Lowell Road to Route 111 or the Hudson Boulevard. In general who can argue with a feasibility study? It is my hope that the proposed feasibility study is not a study with a preconceived conclusion. The Town Planner and Engineer, in their letter recommending the feasibility study to the Board of Selectmen, quite correctly state the traffic in Hudson is an important issue has dominated at present by traffic to and from the Sagamore and Taylors Falls bridges. It is predominantly limited to morning and evening rush hours. Unfortunately, it is mostly the result of commuter traffic from Hudson and from neighboring and not so neighboring communities. In other words, this is a regional issue, not just a Hudson issue. Just as an aside, I note that Hudson and Nashua have two bridges crossing the Merrimack River, two crossings. The next Merrimack crossing is about 11 miles north at the Litchfield Manchester town line, roughly. And in the next 10 miles, there are seven crossings of the River. East-west traffic is a regional problem. While the symptoms show up in Hudson. The problem is regional and needs to be viewed and addressed on that scale. Roadway construction in Hudson will not solve this problem. I do applaud the Town staff and emphasizing the need for consideration of the environmental impacts of the Hudson Boulevard proposal and the need for EPA feedback. In a past life, I was a member of the Hudson Conservation Commission and as outlined in a two February 2014 memo from the Commission to the Planning Board, the commission raised a number of environmental issues with the proposed Hudson Boulevard route, including inadequate mapping of existing wetlands and the proposed crossings of Limit Brook Swamp and Mile Swamp. I would also note that the development along the proposed corridor in the intervening eight years is only likely to strengthen roadway associated drainage issues. So basically, it's my opinion that the Hudson Boulevard is not the solution, necessarily the solution to the problems of traffic in Hudson. It's a regional problem and needs to be looked at more than just with the Hudson Boulevard.

Jenn Rousseau, 123 Wason Road

Ms. Rousseau said, states members of the board have authority only when acting as a board legally in session. The Board shall not be bound by any action or statement of any individual board member, except when such statement or action is at the direction of the Board. Given these facts, it

appears that the Town Engineer and Town Planner made a decision for the Town without consulting and getting approval from their governing body. If this is true, I would implore you to consider the two outcomes and action items. The Board of Selectmen should hold these employees accountable for their actions. This is a slippery slope, and it must be clear that this sort of insubordination will not be tolerated. Two the Board of Selectmen should immediately issue a corrective statement to the state's Public Works and Highways Committee, informing them what has happened and that the town has not determined the need for this feasibility study or inclusion of the Hudson Boulevard on the ten year plan. The same communication should be issued to the State Senate prior to Thursday, where they plan to meet and hear Hudson, I mean, House Bill 2022 and vote to possibly accept this less. The DOT Commissioner should be communicated with so that she understands what has happened here. In closing, the members of the select board should not feel pressured tonight to make a motion to accept what has happened here. Please stand firm and send a message that we don't do things this way. You are the elected leaders that our residents have chosen to be here and to make monumental decisions of great consequence, not town planners. Not town engineers. Moving on, I would expect you as a Board to seriously discuss how this town should address legitimate traffic concerns in public with full transparency. Weigh all the alternatives equally and leverage the traffic study committee and the work of the master planning development that has gone on and make the best decision for our town. Not the quickest one. Thank you.

Jordan Ulery, 36 Baker Street

Mr. Ulery said, used to live at 37 Webster Street, but the Fire Department decided I should live at 36 Baker Street. So that's where I live. I've lived in Hudson since 1972. I've been here long enough to remember when Hudson had the distinction of being called the most heavily sued community in the state. Primarily for land use, land use board actions that were contested in court and Hudson lost and lost and lost. And go on. It costs the taxpayers, myself included, quite a bit. I'm speaking today because this morning I was made aware of an allegation totally without merit and based completely upon false beliefs by a member of this Board. The good selectman called myself a liar and myself and another member as acting with devious intent. The person demanded the Public Works Committee disregard my and my and the other member's testimony. I'm wondering by what right this Board member felt that they could limit another person's right of free speech, that is, unless they themselves had devious intent. Or perhaps they just felt that they are the only one with any standing. Disagreement is fine, but directing a House Committee to disregard another's testimony as absolutely egregious. Apparently, this Board member was trying to intimidate a member of the of a subordinate board. I'm a member of the Planning Board. It sure seems like that to me. No evidence, just accusations were present. Such accusatory behavior was known as the terror in France. In fact, this selectman made reference to a non-existent proposal to bolster his view that I was engaged in devious intent. Apparently, the selectman was totally unaware of the so-called facts when he wrote what I consider a slanderous email to the Public Works Committee in Concord. I learned in school that lack of knowledge can be stated with a signal word ignorant. That single word may apply in this instance. I would like to inform the selectman that based upon information and belief that the email sent was treated with the respect it deserved since it dealt with a subject that was not before the Public Works Committee, it was put in the thank you file. I would also like to inform this apparently all-knowing selectman, that's my personal opinion that his email demonstrate a complete lack of knowledge regarding what was presented before Public Works. All it needed to be done was watch the public record. Apparently, the selectman is unaware that New Hampshire is a Dillon rules state or the Board of Selectmen do not govern the Board of Selectmen and every community in this state, and every town, whether it's a commission or whatever, administer. They don't govern. Governing is done by the state, not by the towns. As most boards know that you guys have a limited role in administering state law, the selectmen don't represent the people. The representatives in the House represent all of the people, the senators represent various communities which cross state lines and then the county commissioners manage the counties, they administer the counties. I would also like to recommend or remind the selectmen that any work that I or any other member of the house from District 37 did regarding traffic congestion on Lowell Road was a result of a publicly made request by

people at a Planning Board meeting. This was a public meeting. The request was made to do something and to find out about it. And to get something done. Something. We did. I would also like to remind this particular selectman, as apparently most of you know, but not at all. Selectmen cannot make a slanderous remark about members of boards over which they oversee. There are consequences for such actions. One final note here, the selectman bragged that he was a voice of public records access. I have done a lot of work in judiciary on public records. I served on a joint legislative commission that dealt with. Public records access helped write the ombudsman bill that will probably pass. Made numerous modifications to various bills, and I'm a co-sponsor of a membership attendance bill that is now being heard. I have yet to recall or find an email or letter or having seen this person at any of those meetings making any comments whatsoever. I've worked with the New Hampshire Right to Know people and I reached out to the municipal association and they can find no information. Perhaps it got missed. You know, things don't show up. So perhaps it's there. And I also find this interesting because that particular selectman seemed to think that blind records, blind copies of emails are OK to send. When they're not. But because when we operate as a Board, everything we do is open to whom we send it and from whom it's received. It's open. The emails I received, so long as they're approved by the House Attorney, are open records. I do believe the selectman overreached, and I hope that the Board has it continues its deliberations will take administrative action and issue an apology to myself and the other representatives from the Town of Hudson. And again, I remind individuals that the work that was done was done after a request at a public meeting, and there's a video record of it. Thank you.

Ted Trost, 63 Rangers Drive (handed out a map)

Mr. Trost said, I've got two things that I want to talk about tonight. One is I see on the agenda there's an item on there for the acceptance, possibly, of an anonymous donation to the Police Department. I don't think this is a good idea. It's unclear from the memo whether the individual or group making the donation is known to the Police Department or not. But I believe government operates best when it's transparent, it's trusted, most honest, transparent and when there are anonymous donations going to the Police Department especially, I think that that just looks bad. If it were up to me, not only would this be declined with gratitude, it's a great offer. It's always nice to have more training made available or the cost to the town being reduced. But this looks bad, and I think donations like this should not even should not only be denied but should be illegal.

Chairman McGrath then said, Mr. Trost, let me just stop you, please. The donor is known to each member of the Board of Selectmen and the Police Chief as well. It's just not known to the public because the donor didn't want any publicity for that. Mr. Trost replied so in my opinion, that's better than what I imagined it to be, but probably still doesn't look great. I still think perhaps I still think that that's not a great look for donations like that to be anonymous because it can have the appearance of an of an influence that it shouldn't have. So that's my thought on that.

Mr. Trost then said, as you can see from the map in front of you, I'm here to talk to you about the Hudson Boulevard or the circumferential highway, depending on how it's referred to. So once again, we're here to talk about what I call the zombie project. It keeps getting killed and it keeps coming back to life. We all recognize, I think, that something must be done to reduce the congestion on Lowell Road, but doing something does not mean the same as doing anything. On the map I provided to you the blue line shows the proposed route for the circumferential highway. The orange line shows a similar route using Wason Road, Bush Hill Road and Kimball Hill Road. We're told that drivers who drive between the bridge and the south end of town, who wish to go to the eastern part of Route 111 or in the reverse direction will benefit from the proposed circumferential highway and traffic will be reduced. What I don't understand is how this circumferential highway would reduce traffic congestion and Lowell Road if those drivers are not currently using the orange route, which is almost identical. An option I think should be considered in order to put drivers onto Wason Road more quickly and more easily would be to construct a tiny portion of the blue route from Lowell Road

connecting to Wason Road, just east of Cin-Free Drive. The proposed connection location is noted by the red arrow on the map I provided. This would simplify driving and encourage many drivers to use Wason Road instead of instead of Lowell Road. Perhaps an overpass or a large roundabout at Lowell Road at the circumferential highway if that plan is enacted. Finally, I think a major reason why the circumferential highway has not proceeded at this point has been due to E.P.A. limitations on building over through or near wetlands. What I don't understand is what's changed about the wetlands or the EPA that would warrant spending a million dollars in a new traffic study, even if that study shows a highway would help with congestion. The EPA is unlikely to issue the necessary permits, and then \$1 million of our study of our money has been wasted.

Selectman Morin was recognized and said Wason Road is the circumferential highway right now. But you are well aware as being a firefighter and responding to that how dangerous that road is. Am I correct? Mr. Trost replied there are some accidents on there, certainly. Selectman Morin then said, so what would you suggest? We've already got it to make this road safe. How many fatals have you been to on that road? Mr. Trost replied, one. But again, I was a call firefighter. Selectman Morin replied, right. So what would you suggest? How, how, how can we fix that road to make it safe? Mr. Trost replied, I would imagine the DOT would be the experts on that, but I'll suggest site distances maybe take some of the dips out of the road, smooth it out more. It has to cost less than building an entirely new highway through untouched wilderness. Selectman Morin replied, okay, and I agree with you. My problem is people didn't want us to take money out of it to do anything yet how much this is going to cost? I'm just asking. Mr. Trost replied, how much what would cost? Selectman Morin replied, how much it would cost to fix Wason Road. Mr. Trost replied, I would imagine it has to cost way less than building an entirely new road. Selectman Morin then said I'm not arguing that Ted. I'm not arguing. Mr. Trost said I have no idea. But, but I'm not hearing that being discussed. All I'm hearing is we have a new highway. Selectman Morin then said the reason you're not hearing it discussed at this point, because we're going to inconvenience some residents again. One way or another, somebody is going to get inconvenienced. Ok, so everybody here tonight for a reason. So then we say we're going to start widening Watson Road. We're going to take your property, we're going to straighten it out. We're going to be right back here again. That's why I'm asking you what? What's your plan? What do you think we can do here? Mr. Trost replied, I think, I think Widen Watson Road, maybe. Straighten out some of the curves, take out some of those dips. There's a lot of up and downs where you can't see over the top. Selectman Morin agreed saying, absolutely. Mr. Trost continued on saying, you know, I don't like to see that. I don't like to see property owners lose their land. But I think that's a more realistic, less expensive approach to solve the problem that we have now. I guess that's what I'm saying.

Chairman McGrath then said I kind of think I kind of think that we're getting ahead of ourselves because...Selectman Morin interjected saying no, no, he brought something forward to us so I just wanted to hear a little more. Because it's the circumferential highway now. It really is. But I've been there for many people that have been killed on that road. That's all. Thank you.

Chairman McGrath then said, I just think that I think that there's been some misinformation that's gotten out to the public. Selectman Morin replied, we can deal with that later. Chairman McGrath continued on saying, yeah, that's just pointing it out so that people don't think that it's a done deal and that we're getting a circumferential highway. I just.

Xen Vurgaropulos, 5 Muldoon Drive

Just speak on what Representative Ulery said a minute ago. I'm just getting into town politics for a little bit now, so I want to know if just any one individual of any board of any committee can act as an individual at any time or does that violate the code of ethics 53-4 RSA 3139 alpha, where it says no town official or employee shall claim to act on the behalf of the selectmen, a board or its departments without prior authorization from said body. Selectman Morin responded to Mr. Vurgaropulos saying let me let me clear up what happened here. Have you watched the video? Mr.

Vurgaropulos replied, I have. Selectman Morin then asked, ok did you see myself say anything at that meeting?

Mr. Vurgaropulos replied, I never said you said anything sir. Selectman Morin replied, I'm just asking you, did you see me? Because there is accusations that I was there representing the Board of Selectmen? I never said a word. Mr. Vurgaropulos then said I Mr. Ulery did. I saw it on TV. Selectman Morin then said but you just asked, can we as a board member? So I'm asking you the question. Did you see me say anything and represent myself as a member of the Board of Selectmen? Mr. Vurgaropulos replied no. Selectman Morin then said Ok, so that's cleared up. There was no Board of Selectmen member there, speaking as a board of selectmen or representing themselves as a board member. Mr. Vurgaropulos replied there Planning Board member there. Mr. Ulery. Representative Ulery is a Planning Board member. Selectman Morin then said I'm not gonna answer for Mr. Ulery. I'm gonna answer for me. Mr. Vurgaropulos said that's who I'm talking about though. I wasn't talking about you. Selectman Morin replied, I misunderstood. I'm sorry. Then I apologize. Mr. Vurgaropulos replied no I was reading the code of ethics verbatim.

The Chairman then said we're going to, you know, we're going to have to do this in a respectful and easy manner. We're not going to have a free for all here. Mr. Ulery, did you want to say something about anything that was just said? Mr. Ulery replied yes. A person can sit on the planning board, but if they hold another position, they can do that. At that meeting it was a request of myself and Representative Rice as representatives, not as planning board members to take action. There's a difference between the two. Mr. Vurgaropulos replied okay, I appreciate the position. That's fine, I'm just going to carry on with what I wrote, please. Obviously, I'm not in support of this highway unless I really can see the finer details of this. Personally, I find some of the politicians are very skilled at what they do at their craft, so I'm just going to leave it at that. Um, I come to you today because I had a couple of interesting conversations with Mr. Ulery on a social platform, but then I watched this meeting and it had some further questions. So I watched Representative Ulery and Kim Rice speak at the New Hampshire House of Public Works and Highways meeting on 2/10. Mr. Ulery was asking for \$100 million for a feasibility study, and sorry, I apologize one million. I wrote one million. It just I got ahead of myself. Now I heard him a second ago, just state that it was requested by the public that we review this. I think that's taken out of context just from hearing this. I believe the public comment was an overall impact study of the whole town and region need to be made and what I might be wrong unless there was a specific request made publicly that I did not see, which may be the case stating I want the Hudson Boulevard revived. I didn't see that request. I've only seen the full, comprehensive study of the region being request, so maybe some clarification could be brought forward there. I just want to go over a couple of quotes that he wrote or not wrote, but said at this meeting and then comment on them please. The circumferential highway has always been part of the plan for decades. It's a little bit longer truncated. It was not in the plan this year. I don't know what happened. Well, if you go all the way back to January 8, 2019 at the Board of Selectmen meeting warrant article K, it was voted to be removed five to none. And this is based on a couple of variations, variable factors. The grant billed was denied, so there was no funding federal funding. The project projected cost was forty five millions with literally a quote hopes to reduce to 20 million. I don't know that's a pretty big hope in my book. Hampshire DOT I read the current projected 10 year plan estimate for this project, if it was to be done, is fifty three million eight hundred ninety six thousand eight hundred and sixty dollars. That's a bit higher than originally quoted. Now the letters that the representative presented well over two years old. I don't know what. I know we had COVID and all that. I think if he wants to bring those bodies forward, he might want to have them retyped and re-letter headed to present date. Because I don't know if those politicians still feel the same about that highway. That's my personal opinion. Some other quotes. Lowell Road is a failed road. Right now to get from the intersection of Sagamore Bridge to PMA road reduction from four to two lanes during rush hour takes about 30 to 45 minutes and the distance is less than a mile. Traffic is heavy. Traffic is heavy. The majority of the traffic is not Hudson residents, it's the surrounding regional towns. This is an urgent situation. Accidents are increasing, traffic is increasing and the quality of life not only for Hudson residents, but the towns he previously mentioned to which he lists all the regional towns are being affected. Now I just want to jump back. I'm not going to have old litigation. I just want to say.

Recently put forward and approved 2.5 million square foot facility with plenty of vehicles and all that, we don't need to go into it. Dakota Properties, 81 condo apartments and the Friary project, that's another 500,000 square feet. These traffic problems didn't arrive overnight. And I know that for a fact, because the project that he brought forward has been trying to be built since 1959. So you telling me from the time that these last three projects were approved, traffic has got so horrendous that now we have to build the new highway. That's what seems a little ridiculous to me. This was voted down by the Board of Selectmen for a reason, and I'm having I'm really struggling with a couple of different things here because. I'm trying to figure out how he can operate as an independent individual and just go up there and ask for whatever he wants.

Chairman McGrath asked who's he that you're referring? Mr. Vurgaropulos replied Representative Ulery and Representative Kim Rice. Who used some catchy phrases to help sway the House with I live on Suicide Lane. That's not an actual technical term. That's a slang term used. There's not a real term suicide lane pertains to three more lanes or a three lane highway with a two way middle lane. So that's a a buzzword. I don't think that's acceptable to go up there on the house hill and try to get you away cuz I want some money. Now, if the if they want the feasibility impact, I think they should present it to the people of the town, to you guys and said, Hey, this is what I'm thinking. What do you all think? What is the Planning Board think? And we should move on from there? The last thing I'm going to say is Kim Rice and Mr. Representative Ulery stated the jobs are coming into town, so many jobs, so many jobs, good jobs are great. When the whole Hillsborough County unemployment rate is currently at 2.3% and Hudson itself is only at 2.6% unemployment rate, that's only 380 people, and of those people, only a fraction are actually probably going to work because probably disabilities stuff like that, and they just don't want to work. So his main concern being that the majority of our problem is traffic from outside of this town. Well, he wants to do is bring more people from outside of this town into this town is what it sounds like to me. That's my opinion. I'm not putting words in anybody's mouth. And the last thing is, I really do. I'm on board with this full, comprehensive study of Hudson as a whole and its surrounding communities to see where we could actually make improvements if it is the highway, let's build the highway. But if it's not the highway, what's not what's not add insult to injury? We know we're hurting. Let's make it right by doing the right thing, not doing the quick things. Thank you.

James Crowley, 4 Fairway Drive

I can cross out a lot of my speech because the chair said, don't be too emotional, which I had thought about being. Well, anyway, thanks for the guidance. We are currently in a cart before the horse mode. We already have a backlog of projects with over three million square feet of industrial use in which we don't even know what the real actual impact is. Do we need the circumferential to open up Hudson to even more intense development? I hope not. Do we want Hudson to become the industrial armpit of New Hampshire, which looks like we're headed toward? I currently see the New Hampshire DOT, NRPC, state representatives and even the governor going out of their way to kill the current character and quality of life in Hudson with their good intentions for us. Where is our local elected board of selectmen included in all these decisions and good intentions? You deserve more respect concerning the circumferential highway than what you are getting. On new business item 8B, I urge you to send a letter to the New Hampshire Senate not in support of the circumferential, but to voice your disappointment that it is being resurrected without your guidance to do so.

John Debuc, 11 Eagle Drive

I wish I would have gone before Xen because I have a few of the same things I want to talk about. First, I want to start by thanking you for allowing me to speak tonight about this. But I think it's irresponsible to ask the state to fund a \$1 million feasibility study for the 70 year old 1950s plan from the New Hampshire DOT for the circumferential highway or the Hudson Boulevard. Mr. Ulery had asked for this to be funded at the meeting on February 10th, and that's a lot of people talking about this tonight. I did listen to his presentation. A few things stood out for me that were talked about during that meeting. Lowell Road is a failed road. Xen had already said that to get from the Sagamore Bridge, the 30 to 40 five minutes for one mile Hudson being unique, having good turnpike access and a land on which large buildings can be built. He read from the governor's letter to the chairman of the Board of Selectmen, and then the town is ready to move forward, it's been a long time. So I hope any discussion regarding resurrecting this 1950s plan would be discussed at a select board meeting allowing public input before anyone asked the state to use \$1 million of funds that could possibly be used in better ways. You as board members, us as taxpayers and the town officials should never ask for that amount of funds for something that the town residents may not want. I can't imagine that spending that money without full support from the community, so I want to talk about the few things that were mentioned. Lowell Road is a failed road. We all know that. My question is Mr. Ulery has two roles one as a state representative and second as a Planning Board member. If it's a failed road and he understands the railroad, I don't remember any hard questions about traffic for this large South Hudson development. I don't remember any hard questions about traffic for any development that's going into Lowell. Going into Hudson, that's a Lowell Road. So if in fact it is a failed road, why weren't those questions asked in the role as a Planning Board member? And also, why was it voted for yes? If there's so many problems with the road? You voted to approve the project. I'm shocked it was voted to approve and he stated a failed road. And now we're asking to spend \$1 million on a study that could have been funded by the large developer if it was asked, that the coming to town. He was appointed by you to that Board, and you should be accountable for you by not asking those difficult questions during those meetings. I myself have never spent 30 to 45 minutes to get from the Sagamore Bridge to PMA unless there was a massive accident. I travel that quite often and I understand the traffic's heavy. This timeline was shocking for me to hear if, in fact, this is true. I think that the Town Engineer has traffic studies that could show the public that that one mile stretch of road regularly sees 30 to 40 five minute traffic backups. I would ask that the Board asked for this information. It adds the next select board meeting for all residents to see. I would also hope that the town could provide the state with that accurate data for the one mile stretch of road to ensure the DOT has the most updated, timely information for any decisions and funding that come to Hudson.

Mr. Debuc went on to say, Hudson being unique, having good turnpike access and it has land on which large buildings can be built. This bothers me to think this roadway is being pushed to help industrial development in Hudson. There's so many studies that show an increase in traffic as roads are improved. Is this the future for us? Build this road and the Route 128 and 93 traffic then becomes a Route 128 to Route 3 to the Hudson Boulevard traffic. I was confused also when Mr. Ulery read from the governor's letter, and he said the letter was to the chairman of the select board, Mr. David Morin, who was present. This could have been interpreted by anyone watching or present at the House Public Works and Highways Meeting. The Mr. Morin was the chair of the board in his attendance in that role. I hope that I hope that Mr. Ulery can clarify that with his colleagues and let them know that Ms. McGrath, in fact, you are the board chair and was not at the meeting. On February 10th, the letter was sent to the former chair, Mr. Morin. Words matter. Lastly, when Mr. Ulery stated the Town is ready to move forward, it has been for a long time. I'm not one of those people. I know many folks here tonight are not either. How can we know if the Town is ready without public meetings include input from the residents, the people who will be directly impacted by this massive project? If this traffic is not Hudson residents and commuters moving through our town as many have stayed over the years, has the state looked at other options to get folks to London there in Windham? Could exit five or six be redesigned or is the only option blasting a new roadway through the middle of our town? Should this \$1 million look at alternative options that 1950 project?

Mr. Debuc then said, the last item I like to speak about is the environmental impacts that this project will have. I've read the EPA stopped the continuation of the highway due to severe damage it would cause for the environment, harming rare plants and wildlife that thrive in many of those areas. This needs to be revisited before we ever asked for \$1 million for a feasibility study. It was mentioned that a group of people from Hudson want to acquire some of the state owned land that this road would go through to build a park. Wow, what a forward thinking idea. Let's build a park for our residents instead of a parking lot. Thank you for your time and hopefully your support to do the right thing and put the brakes on this irresponsible ask from the state to use \$1 million on a feasibility study for this project that could forever ruin our precious wetlands, wildlife and the town that we all live in. Thank you.

Chairman McGrath then asked, Mr. Ulery, do you wish to say something? Mr. Ulery replied from the back of the room saying, yes. There never was any discussion over circumferential highway. There was a discussion of the first arc of that, the old plan. This is now considered the Hudson Boulevard. Which is not a major highway, but it's more along the lines of what exists over in Litchfield, their Connector Road that was built there. It runs parallel, essentially parallel with 3A take traffic load off of that and just distribute it out whenever there's a reference to something regarding the Hudson circumferential highway that's completely to use the current term fake news. Thank you, Madam Chair. You're welcome. Oh, Madam Chair, yes. The packet of information with the existing letters in there that each one was dated and the committee got the entire package with the dates on them. Thank you, Madam Chair.

Mr. Debuc was standing at the side of the room and was recognized. He said Madam Chair, I do take offense to the word fake news. I said both a circumferential highway and I said the Hudson Boulevard. We all know what we're talking about what was spoken at that meeting. So to stand up and to use the word fake news to a resident that's trying to protect the town ma'am, from a state representative and a sitting planning board member, even if he's speaking as a as a citizen tonight, I think it's pretty irresponsible for him to use the word fake news on me, and I really take offense to that name.

Jim Dobens, 4 Eagle Drive

Mr. Dobens started off saying, and I am going to be nice. Chairman McGrath replied, Thank you. I'm going to be nice as well. Mr. Dobens then said, good. I really had no intention on coming out tonight, but after I had yeah, they laughed because I was asked to watch a meeting and kind of got stirred up. But but I do want to kind of thank Mr. Ulery for what he said at the state meeting. I do because it kind of brought a few things up in my mind. I was actually stunned by a lot of things and kind of put a lot of questions in my mind. Mr. Ulery is a member of the Hudson Planning Board, and he did address the state officials about getting funding to resurrect what is now becoming called the Hudson Boulevard. I don't care what we call it. It's not a road that's going to go around. You can call it whatever you want. And I did listen to Mr. Ulery and he called out some things. Traffic is so bad it takes 30 to 40 five minutes. I don't need to get into that. Our roads have failed and are now a safety concern. Quality of life all this is creating is now really becoming an issue. He cites that Hudson will continue to develop because we have opened things up with a 50 foot building height that is conducive to more development in Hudson. Frankly, that's the biggest crime and hoodwink ever committed in Hudson on its residents, and I'll take that debate up with anybody. He cites the governor's support of the projects being built in the roads that he would support should the projects go through. Well, I'm just curious because he brought all of that up. He was admitting to all the issues we have and yet approved the largest logistics center in the state with over 1,200 tractor trailer docks and parking spaces, along with multiple thousands of car trips that will be made per day on our road. Didn't make sense. He has due diligence to this town to protect this town from impacts beyond normal impact. This isn't normal impact, and we're now beginning to look at another logistics center being proposed that will add hundreds of trucks and hundreds of cars, and we've just put up some

high density housing, which is absolutely gorgeous, Marilyn. Chairman McGrath replied, thank you. Mr. Dobens continued on saying just gorgeous over there. Think they need some shutters. Chairman McGrath then said I agree. How gorgeous it is. Mr. Dobens went on to say, that's going to add even more issues beyond traffic. So you can just imagine the traffic and the infrastructure impacts that a lot of this is going to have. In fact, I'll even go out and say that even Elvis called out the elephant in the room about a year ago when he said our roads could not handle the traffic from the HLC, never mind the rest of the developments. Should this go in, HLC can't solve the traffic issue through mitigation. That's not going to happen because we've already failed, and these other developments are only going to compound it. Adding a new highway or a boulevard to this town in Hudson is only going to trigger three things. More traffic, and I would encourage everybody to go back and read the theory of induced traffic demand. Adding more roads and lanes only makes more traffic. It makes traffic worse. It's been proven everywhere. This was presented to him and the Planning Board last year. I don't think anybody listened or paid attention. It opens up more of our G and G1 zone land to add more development, like the logistics and development centers, because the 50 foot height is going to drive them all in. They're going to be like little flies. And then high density housing. Those projects are now going to start to surface. So all of these things are going to happen. I was the one that did ask for a complete impact study from this board, which is not just about traffic, but it's about all of this development and what it all will bring. Mr. Ulery did talk about safety concerns. Well, let's start talking about adding things like air pollution monitors and water and noise monitors, as well as traffic counters to protect your residents. I don't see those things being added as contingency, and I view that as a derelict duty by the Planning Board. We asked for them. They all got turned down. So I urge this board to take some action. Where is this overall impact study? So real decisions can be made on where this town goes. I would suggest that the Board of Selectmen find a way to suspend the Hudson Logistics Center in the Friary logistics projects as they cannot be handled by this town's infrastructure. The impact is too great.

Mr. Dobens went on to say and the other thing that bothers me is that I'm trying to understand. Why he and supported by other Town members being at that meeting, spoke about getting that project back on the 10 year plan for the state. What I don't recall any endorsement by any resident or any green light given by any person, whether it's a town resident, a board of select member or anybody to approach the state over it. It's not speaking for me. All of this simply reinforces in my mind how the town residents have been let down. You still have a chance to fix this mess. You really do. And also, I just want to tell everybody that's watching tonight. Get out and vote, please. March 8th. A lot of Warren articles, especially where our articles six, seven and eight, please vote yes so we can prevent further destruction of the quality of life within this town. Thank you for your time.

Kathy Leary, 8 Par Lane

I'll be brief because a couple of things I was going to say have already been said. A couple of things I just would like to add. I first moved to Hudson in 1988, and at the time shortly after we moved in one of the first things my husband and I did, we were attending meetings on what was then the circumferential highway. So it's something I've been kind of interested in and followed for a long time. With regard to what's now being called the Hudson Boulevard. I have to admit I'm not an expert, as some people are as far as the exact map of where that will go, but obviously in any highway being built is going to be taking land, either land at the town owns. Potentially land that other private residents own. And it would be interesting to get feedback from residents to who might be interested to know that you're going to have this potentially new highway, either in their front yard or their backyard or through their property. They may not be that happy about it thinking that this has been, you know, long gone. The other issue talking about, you know, the EPA and some of the wetlands issues. It's my understanding way back when that that's the main reason or one of the main reasons why this thing never went anywhere in the first place.

Ms. Leary went on to say, just a couple of like traffic issues I drive from the south end of town, up to Alvirne every day for work. Even if we were to build this particular road, it might help with traffic

heading out towards 111 towards Windham. Any traffic that's trying to head north up to Londonderry, up 102, it's still going to be going up Lowell Road to 102, up past Alvirne. I can't tell you how many times I'm behind or in front of tractor trailer trucks who are not using the highway. They're going up 102 heading up to Londonderry and 92 in that way. With regard to the road, depending on how it would be built if it's going to be a true bypass or is it going to have exit ramps on and off this proposed Hudson Boulevard? It does open it up to further development all along it, as opposed to it being a true bypass. You could end up just being another avenue for bringing in further development along the road. The last thing I thought of when I was looking at the agenda for the for tonight's meeting, I just thought it was kind of interesting. I'm not gonna make any comments on it. I thought it was kind of interesting that on the agenda, this item was simply referred to as, I think I forget the exact wording of it.

I don't...I have it right here, so I'm accurate. Feasibility Study for Lowell Road to Route 111 (Central Street). There's no mention of Hudson Boulevard or whatever, so it's for somebody who perhaps wasn't following a lot of this. They would have no idea what was being talked about tonight on the agenda, and they might see Lowell Road, Central Street that needs help. All in favor of it without knowing that we're talking about an entirely new road cutting through land. And the other thing I would just mention I would just have to think about while I was sitting here is, I know in past years some of the items on the past warrant articles I think it was one of like the Rangers Forest. There were some lands that I remember that voters voted to put, I think, into either town, forest or conservation land that had previously been town owned land. I'm not sure if any of that was earmarked for any of these roads, so it would be interesting to look at to see how much of this road, the area where this potential road would go is actually available land. Thank you.

Rita Banatwala, 29 Fairway Drive

Ms. Banatwala stated her name and address for the record. Chairman McGrath replied saying Oh, you're the person that I've seen on a lot of correspondence. Ms. Banatwala replied, it could be cuz I have written some things. Chair but so I've seen I've just I've in fact, I just mentioned it today that I saw your name in some other correspondence. Ms. Banatwala replied yes, you probably did. Yeah, basically, I want to just I don't want to repeat everything that everyone else has been saying, because that's a waste of time. But really, it's shame on all of us for approving or allowing our boards to approve projects knowing we have a vital traffic problem. It seems that everyone is in agreement that we've got a failed major thruway through Hudson called Lowell Road. Yet we're approving huge projects that are increasing traffic. And I listened to all those hearings. People on the boards were not asking questions about traffic. It was only citizens that were asking questions about the traffic, which is the shame, maybe citizens were asking all the good questions so no one else needed to. I don't know. I don't know what other discussions went on at off times, you know, whatever. But it's really shame on us for not taking care of our infrastructure before allowing new developments to take place in town. I want us all to keep that in mind as we're approving things in our town, make sure we've got the infrastructure, do we have the services? And as other people have requested, and I tried to second it weeks ago, let's get a study. We don't know if our police and fire can handle things. We already know our roadways fall apart, but we've got to get our infrastructure in place before we can have any more developments in town. So I guess my request is put a stay on everything. Don't let anything else happen until we know the impact and can handle that impact and get the infrastructure there first. We have to get the plan out before we can build and then we can make this a great town again. Chairman McGrath then said I'm not certain that we can do that and I don't I don't. I honestly don't know the answer. But a number of years ago, the Planning Board wanted to put a stay on development and we had to meet certain criteria. And that's it's some sort of an RSA. I don't know. I don't know if it's still in existence or if it was abolished. Ms. Banatwala replied saying, but I think we need I mean, we know we have problems, so let's figure out how we can fix those problems. That's all I want to do is try to fix it so we can make everything better for everyone.

Chairman McGrath then said so my point is so that everybody doesn't go marching out of this meeting thinking that, oh great, they can, they can put a stop on all development. It's not as easy as that, and I don't know what the answer is. I know at one time we tried to do that and we really we weren't able to do it. Well, can we dig and find out? I don't know either. Chairman McGrath replied, we can. Yes, we can. We can look into it. Ms. Banatwala continued on saying let's dig and find out and see what we can do because I really think it's important that we get our infrastructure in place and then we can invite development in and we can have the upper hand and get the things to make Hudson great again. Chairman McGrath then said, but let me also point out to you, and I'm not I'm not saying this because I'm trying to get all of this development into the town. Ms. Banatwala replied I know you're not. Chairman McGrath continued saying, if you know my background, you probably do know that. But people own property, and if they decide that they want to sell it and get the biggest value that they can, and then all of a sudden, we're not allowing any development in town. They can't, they can't sell their property and maybe they're in a position where they really need to. So that's something that again, you know, like as much as I, I can't I'm not even going to go any further than that. You get the message. Ms. Banatwala replied to Chairman McGrath saying, we just have to get them that our board asked the pertinent questions about our infrastructure. Can we support it? Can we take the impact of whatever the development is going to be given us? That's what we need to do. We need to ask this question. There are many opportunities that we could have put holds on different things at different times and said, No, we need more. We could have had developers that know you've got to pay for this overall impact study. No, you've got to do something about this traffic issue. Yes, we bought some land and got some rights to widen, some roads to get over to the Sagamore Bridge and stuff like that, but we could do more. That's all I'm saying is basically let's try to do more going forward because what we've been doing, status quo isn't cutting it. And I mean, people have admitted we've got failed roads. But if you go back and listen to the hearings when traffic was being discussed, oh yeah, that looks good. That looks good. There were no questions. Chairman McGrath replied well, you missed the part when I was at the meetings before I had the stroke. So it's not fair to say that those questions weren't asked because...Ms. Banatwala interjected saying some people did ask. You did ask some. I remember that, but I'm just saying more questions can be asked. Let's not be afraid to ask the questions to make sure our infrastructure is supported because we know it's weak right now.

Sue Gosselin, 9 Fairway Drive

I was before you about a month ago and I had talked about optics and what I'm seeing at the Planning Board and what I'm seeing in the way that things are being voted in or out. And I said that it just didn't look good. When you talked about why you didn't want people voted in on the Planning Board, you had a specific reason. And I listened to you. I started doing research, and that's when I started watching the Planning Board. And I referenced December six, sorry, December of 2016. I'm sorry. I think it was. The 18th around there that the same developers who were asking for things back then ended up getting them via the planning board. Granted, the residents voted for it, but the way they were presented wasn't necessarily what was presented in the planning board meetings. I find it a little. Interesting that about a month ago, when I came to talk about that, the developer, the same developers were at the planning board meeting. They were talking about how much industry they were going to want to keep that 50 foot building rage out on 111. And now all of a sudden, Hudson Boulevard is back on the. The docket. Just because you're paranoid doesn't mean people aren't out to get you. I'm just telling you from somebody who's watching that the optics are not looking good for that. All of a sudden the developers are talking about developing more and more on 111. And now we're looking to put a fast lane to developers to develop off of 111. Watch the time, you know, there's a sequence there. I'm not saying that's what it is, but it's just really convenient that all of a sudden within a month of a developer talking about how much they want to develop out on 111, we're giving them a speedway through this if it goes through. So thank you for your time.

Dean Sakati, 11 Fairway Drive

I mean, some of the same that's been brought up. I was absolutely stunned when I watched the video and I listened to Mr. Ulery, talk about the traffic and I completely agree with them. It's a mess. All the comments that have been said that Mr. Ulery made there, they're absolutely correct. The problem that I had was absolutely stunning to me was that he sits on the Planning Board and I listened through every I went to every HLC approval, meeting, a meeting for their approval and the debate, except for you and Mr. Oates, right? Was was nonexistent. It was unbelievable. I was absolutely stunned at the lack of critical thinking. Again, except for you, Madam Chair, as well as Mr. Oates, right? Is there was no, no critical, there's very little critical questioning, maybe some from Mr. Coutu as well. But the point being is how he could sit on that Board and be so concerned about traffic, but never ask questions about the traffic itself. And to me, it made me think, I don't know if I'm being harsh here, but it feels to me to be a dereliction of duty negligence, right? That you could actually be on this Board and not ask those tough questions when he obviously a couple of months later, you know, was able to express how strongly he felt about it. And, you know, maybe Mrs. Gosselin's point is there is a bit of a concern with what people see. So in other words, you know, again, I don't know if I'm connecting dots or making dots, but you bring a developer and they come in, they kind of scoot in and get the 50 foot height for buildings approved. They they're the same developers who are actually listed on the PDF's marketing HLC's buildings. They're the same developers that are writing letters to the to the Union Leader and to the Telegraph supporting this type of development that's all within their right. But the point being is that, you know, is it are we doing what's right for the residents or are we going too far and just trying to promote this laissez faire development that we've seen? And to the ordinary resident, it looks like this whatever you want to call it, boulevard is just another piece in that overall puzzle. So again, not sure if it's making dots, connecting dots, but that's the way I think you'll find a lot of people feel. So I'll end there, and I think that was brief.

Paige Schaller, 213 Fox Hollow Drive

I just had a couple of questions. One, I did watch the video from from last week and I did see where they were saying that they didn't have the money in there for the million dollars because for some reason this feasibility study hadn't been brought up. Previous to that. And Mr. Ulery, or I can't remember if it was representative or representative, Rice was asked, well, which town would you like us to take the money out of to give to you? And they didn't have an answer for that. So I'm just wondering if you vote to sign for the feasibility study today where's that money coming from? Because apparently they didn't know where it was coming from, either. So if we're voting to do this or I'm sorry, if if you well, Board vote to do it, are we then as taxpayers is going to have to pay the million dollars because the feasibility study was asked for?

Jordan Ulery, 36 Baker Street

Chairman McGrath replied saying, so, so Miss Rice and Mr. Ulery are representatives. They're not, they're not obligating us. We'd have to vote on any spending and that hasn't come before us. So you know, I think that they were talking about out of the Legislature, there must be a budget or a bucket of money that they can access. Am I right, Jordan? Representative Ulery replied from the back of the room, that's correct. Chairman McGrath continued on saying so it would come out of the Legislature. It wouldn't. Their budget, it wouldn't come out of the Town's budget. Ms. Schaller replied oh, okay cuz in the video, it sounded like he was asking the Legislature to get it into that bill that was in front of them that day. And because for whatever reason, it was too late getting into it, it wasn't accounted for. Chairman McGrath responded to Ms. Schaller saying, so that's their bill that they're talking about. It's not something that we're going to be voting on, you know, as far as that that it may end up coming before us to, you know, send a message to the Legislature or the state Senate saying that we either support that or we don't support it, but it's not before us yet. Ms.

Schaller replied. Ok. All right. Another question I had was I just wanted some clarification and some stuff I saw in social media today where somebody was talking about we didn't get Tuscan Village because, you know, a similar project like that was voted down by the voters before. And I think you select member Morin have mentioned before you're very familiar with the projects that have gone in there that one of them failed because the retail economy went down and the developer pulled out, another one failed because it was a casino, which to this day, we still don't have legalized casinos. And another one failed. Selectman Morin replied the retail one is in Merrimack now, and they're making a killing. Ms. Schaller replied Yeah, yeah. But back at the time it tanked? Selectman Morin replied no Things they they decided to move on and went to Merrimack. But the casino, the casino came in, but it really never went to a planning stage. And then what was the other one? I'm sorry. Ms. Schaller replied, I think the other one had failed. Yeah. Lifestyle center. Yeah. Yeah, that that was proposed. But that one, there was a lot of residents that didn't want it. Ms. Schaller replied we don't vote on that. Mr. Sakati, who was on the side of the room said, No, I live on it. I know that story. Yeah. Can I? Ms. Schaller said Yeah, because one of them was a recession and one was...Chairman McGrath, speaking to Mr. Sakati said if you have the right answer, you can. You better be sure because I live in that area and I know the answer. Mr. Sakati who was standing in the room, said I about it. I met with the developer. They were anxious to build the property. They laid out the plans. They called me, inaudible, called me to tell me that they were closing down that project and they were going to team up. But there was another project that was going in where I think Costco's going in on Spit Brook Road. He said they were, co, investing in that property. And that was basically and that project was also sunseted. At that time, there was a lot of free money that was flowing into real estate trusts. It was before the real estate, before the financial crisis. So what happened was these developers want to put that money to work. They need projects. They didn't get, you know, this project was probably a little more evolved then they teamed up on the other side of the river. Chairman McGrath responded that's an answer that I've never heard before. Mr. Sakati replied, that was my conversation with inaudible. Chairman McGrath replied well, he might not know either.

Ms. Schaller continued on saying so anyway, long. In short, though, the social media post said that the town residents voted it down. And as far as I know, we're not allowed to vote on the sale of someone's personal property, so I just wanted to clear that up, and I know you've talked about, of course, that's why I was asking you the question. So thank you. Selectman Morin then said but just so there's no confusion Friars Drive was voted down by the Town. Ms. Schaller then said the purchase of the land there yup. Selectman Morin then said so make sure that's not what they were talking. Ms. Schaller said No, they weren't. No, they were specifically talking about it. Selectman Morin replied, so they may be confused at Friars Drive was voted down by the Town. We had an option to buy that. Ms. Schaller replied yes, that's right. The voters voted down purchasing that property at the time. Unfortunately. Chairman McGrath replied we lost it by twenty five votes. Ms. Schaller then said which is important to get out and vote on March 8th, yes six, seven and eight.

Jordan Ulery, 36 Baker Street

Mr. Ulery said people have asked for a reference that's RSA 674-23 on the limitation of moratorium. You have to do an ordinance. Chairman McGrath said Ok. So that's that's in the in response to the question about stopping development. That's the lady over there. All right. Ok.

Xen Vurgaropoulos, 5 Muldoon Drive

Mr. Vurgaropoulos stood by the public input table saying, real quick, I promise. Chairman McGrath replied saying you're got to be really quick because we've got other business to do. That's really

Important. Mr. Vurgaropulos said I'm not even gonna sit down. To which the Chairman said you can sit down. Mr. Vurgaropulos replied I'm not going to get as excited as last time. I learned my lesson. So I apologize for being excited last time. I just had a question about the master plan is considered a 10 year plan, right? Or is it just...Selectman Roy said its two different things a 10 year plan is they're talking about is a state plan, right? The master plan. No, no...Mr. Vurgaropulos then said so is our master plan due for an update and how long is our master plan (inaudible, laughter talking in room). Selectman Roy said it is well overdue for an update. Mr. Vurgaropulos said I'm just I'm trying to learn. Chairman McGrath then said so in order to have a master plan update, we were doing visioning sessions, of which I'm sure all of these people in the room attended. Right? People replied yeah. Selectman Roy said yeah cuz I did and I saw most of them there. So. Chairman McGrath said to Selectman Roy You sure? To which Selectman Roy replied, yeah. Chairman McGrath then said I'm not so sure because I'm looking at people's faces and they look like they weren't there. But anyway, so they've got the look on their face like they weren't there. So anyway, go ahead. Mr. Vurgaropulos replied that's all I had. I just wanted clarification on that.

Chairman McGrath then said, so we Dave and I talked about that this evening about having more visioning sessions later this year because I think that we should be having them. We should take the opportunity to have all of these people in this room and people that are like minded that want to participate in the development of the town. It's its really important that you attend those and they're visioning sessions. They are. Brian, the last time he set them up, they were, I think, on a Saturday morning and a Wednesday evening. So you don't have to go to all of them, just go to one of them. It's telling, telling the Town Planner and Town officials what you'd what type of development you'd like to see in your town. And I don't know, I didn't see because. I was lucky enough to have a stroke that took me out of the equation for a while, so I'm not sure what kind of response we got. I'm not sure. I never saw the responses. Don't know. (A few members of the audience mentioned covid). Mr. Vurgaropulos then said your definition of lucky in mine is different. Chairman McGrath said I'm really being facetious because this hasn't been fun for me, believe me. But but you know, the visioning sessions when they come up, I mean, if I don't know how we're going to advertise them, but it's important that people go to those because you're going to be able to have input into what this town looks like. I'm coming. I'm coming to the end of, you know, my time serving. I don't know when that's going to be might be at the end of my term, which is in another, I don't know, a year or two or it could be longer than that. But it's, you know, it's important that people go to those things, participate, go to the deliberative sessions, which we just had. There were about 30 people that showed up. That has impact on the budgets and what we're spending your money on, what's being proposed to be spent. So it's critically important and people don't go to vote either. And that's on the spending that's going that's what's going to impact your taxes. So voting is coming up. The candidates. That's a question for everybody, you have to have to understand who the candidates are and who you want to represent you on this board and on other boards. Someone in the audience shouted out Thursday night. Candidate's night. Mr. Vurgaropulos said I appreciate the answer. I'm relatively young and I'm very interested in learning about. And I look forward to having some of those vision sessions and getting more involved. Chairman McGrath replied, yeah, that's good. Thank you.

Jim Dobens, 4 Eagle Drive

Mr. Dobens who was standing along the side of the room said Mr. Dobens said I'll join the vision sessions. I just need to know when they are. Chairman McGrath said they haven't been set up yet. Mr. Dobens replied, let me know. But the question? Absentee ballots? My understanding is absentee ballots are not available. Chairman McGrath replied, not yet. Mr. Dobens then said but we're closing in on the date for election, which is March 8th. Correct? Yes. And the ballots for absentee ballots have to be back in the hands of the Town by March 8th, correct? Chairman McGrath said I don't know. I can't answer that. Selectman Roy said I believe its 5:00 o'clock by 5:00 o'clock. Mr. Dobens then said they're not available now and people are traveling, mail Today takes at least five days. I've already talked to a few people, and I'm going to be one of them going to be unable to

vote because the absentee ballots are not going to be available. And I'm told that I was told by the Town it was the fault of the School Department because the School Department did not have their warrant articles written in time. So again, I am very concerned because I also know some of the people that want to vote and they're not going to be able to vote because it will never get back on time. So then we were told, well, jeez, if it doesn't get here in time, we don't know if we'll accept it. Chairman McGrath then said so, so, so let me I don't know the answer. No, I don't know. Mr. Dobens said I'm a little frustrated with that. I can. I can well understand because voting to me is very important. I make sure when I had the stroke, I was in the hospital and I said to them, I am going to be voting. I'm getting out of here to vote. So it's important. I don't know the answer, but I suspect that Mr. Malizia or someone upstairs can get the answer for you. The Town Administrator said that would be the Town Clerk's Office. Mr. Dobens said we called this morning and that was the answer we got. Again. Chairman McGrath asked, from the Town Clerk? To which Mr. Dobens replied yes. The ballots were still not back and the ballots were still with the printers. Ms. Banatwala yelled from the other side of the room, so that means election results will probably be on hold because they have to uphold to the postmark of when it's postmarked. So results will be delayed. Someone else said there's a narrow window of time if people are traveling. Mr. Debus asked from the back of the room, how is that going to impact deployed members? I was deployed overseas in '16 and '17 and I voted absentee ballot. How does that impact our members in the military that are overseas right now that do not have a ballot right now? Chairman McGrath replied, I can't. I can't answer that. It's the Town Clerk's office that takes care of that process. And I can't speak for them.

Selectman Roy was recognized and said Madam Chair, can I ask that yes to Mr. Malizia to ask the Town Clerk to put something on the website. So that we might get they might get an answer? Selectman Guessferd then said there's somebody else who's leaving town on the 24th, and they were told the ballots wouldn't be ready. Chairman McGrath then said well, shame on whoever is responsible for that. Mr. Dobens said the Town blamed the School Department, I'm just telling ya. That was the answer I got. At this point people were laughing and shouting out and talking over each other from the audience. Mr. Gasdia said I don't know. I signed them a long time ago so I don't know what happened after that. Chairman McGrath then said So I think, you know, we'll have to get an answer and we'll have to make sure that it gets on the town's website.

Deb Putnam, 59 Rangers Drive

I did talk with the town clerk, it's not the fault of the school. (Outburst from the audience) Chairman McGrath said so we're never going to get through this agenda tonight. Selectman Roy replied sure we will. Ms. Putnam then said in defense of the school is that Roger advised me because I was working with Lori Weissgarber, trying to get information about how to get an absentee ballot out to the citizens. Roger advised me that a few weeks ago, the printer already advised them they were behind schedule. So is the problem is with the printer, not with when things were submitted. Mr. Dobens said we know, they're still at the printers. Ms. Putnam replied, yeah, right. That's the problem they're at the printers. Selectman Roy said goddam printer. Chairman McGrath then said you dodged that bullet Gary. Mr. Dobens said you better tell somebody upstairs who said it. Mr. Gasdia replied Yeah, I'll fix it. Appreciate that.

Chairman McGrath then said Ok, so I think is everybody spoken that needs to speak? Because it's now 8:20pm, and we've got we have other business that we have to take care of. So everyone's spoken. Thank you very much for coming out.

Selectman Roy then said Madam Chair. I could make a motion. I don't know if anybody's going to stay to move the item 8B to the beginning of the agenda so that if these folks want to want to know what the result of that this discussion is, they can be here and then we can go on with our... Chairman McGrath asked so what's the motion now? Selectman Roy replied to forward 8B to be heard now. Selectman Guessferd said that's the feasibility study. Selectman Morin seconded this motion. Selectman Roy made a motion, seconded by Selectman Morin to move item 8B to the first agenda item since there were so many residents present for this topic. Carried 5-0.

Chairman McGrath called a brief recess at 8:21pm. The meeting resumed at 8:23pm.

New Business

8B Feasibility Study for Lowell Road to Route 111 (Central Street)

Chairman McGrath recognized Town Planner, Brian Groth and Town Engineer, Elvis Dhima. Mr. Groth started off by saying, thank you, Madam Chair. Thank you, Board. First, let's just understand the timeline and what actually transpired, not what people think transpired. There were several conversations leading up to the Planning Board meeting in which the state reps were asked to speak to the state about a traffic solution. Previous to that, there was a conversation in the summer of 2019 in a public meeting asking the state reps to talk to the state about a traffic solution. Chairman McGrath asked, when you say that, just clarify who requested that. Was it someone from the....Selectman Morin spoke up saying I'll go in that meeting of the Planning Board, State Rep, one of them that went forward for this funding was discussing traffic and how bad it was and nothing was getting done. And when that Rep was done, I said, Well, I have two reps in this room right now. What are you doing for the Town of Hudson to improve the traffic? And from there, first we heard of it after that was the ninth Planning Board meeting as the meeting was started. I was advised that the next day there was going to be a hearing on Bill 2022 and there was some information which was requested as they give to everybody because many of the people in this room have asked the Planner and the Engineer for information. The gentleman that asked for the information not only is a state rep, is a resident of the town, so our Planner and Engineer did what they've done for everybody. Mr. Crowley has asked for tons of information. There's never been an issue. So that's how we get to where we are. Chairman McGrath replied, okay, thank you.

Selectman Roy spoke up saying, Madam Chair, can I ask a question? Chairman McGrath replied, Yeah. Selectman Roy then said so here's my question. So you say that they asked about traffic solutions? Was that specific to the Hudson Boulevard circumferential highway? Did they specifically ask for that information or are they looking for a solution? Well, they are two different things, right? Mr. Groth replied, so in the public hearing portion of this, we heard we have got a huge traffic problem, and but also, we're not keen on the solution at the Planning Board meeting, I don't believe to my recollection that specifically the Hudson Boulevard was identified as the favored solution. In terms of the meeting in 2019. I'd have to check the minutes. I don't know.

Mr. Dhima said I'll add to that. That's kind of part of the conversation tonight. I think a lot of people are talking about building a highway. We're not here for that tonight. We're here tonight to see if the Board of Selectmen will support a feasibility study for any solution, including that, but that that's very important to state and they keep talking about.... Selectman Roy interjected saying, I agree, but that's not what this memo indicates. Mr. Dhima responded saying the memo indicates feasibility study for Lowell Road to 111, because that was a language on the amended SB 2022. If you read that from the state, that's exactly what it says. Feasibility study Lowell Road to 111. And Brian is going to go over it. We're going to try to answer as many questions as possible, but and we're going to talk about what the outcome looks like and then the Board of Selectmen can make a decision either way, no

decision has been made at the state level about this. This is a matter of are we going to get this or not to do a study? That's it.

Mr. Groth continued saying, so the public hearing occurred where they proposed that amendment. And then they asked, what was the Town's temperature on this? How did the leadership in Town feel? So here we are. We're the messenger carrying this amendment, asking what the Board Selectmen feels about it. And the amendment is to support a feasibility study and what we've suggested and or other alternatives, because if this is not feasible, what are other solutions to the traffic problem?

Mr. Dhima then said so we there's been a lot of discussions about what we agree on, what we don't agree on. What it appears that we can agree on is that there is a traffic concern out there, an issue whatever you want to call it. What we don't agree on to what the solution looks like. I get it, some of you are not in favor of circumferential highway/ Hudson Boulevard whatever you want to call it those are two different projects. We're not here to ask for support of that. We're here to basically say, are you willing to have the state come in and fix their mess because they're the one that caused us by dumping a highway on Lowell Road and walking away? We don't know what the answer is. If we did, we wouldn't be here. The Board of Selectmen as of a month ago hired NRPC to look at the overall picture of the town to look what the model looked like for \$7500, something of that line or less. Mr. Groth said, no charge dues paying member. Mr. Dhima added, so at no cost to the taxpayer. This one will provide a similar feasibility, focusing on Lowell and 111, as I said on my previous statements here. You're going to see the good, the bad and the ugly. Now with this said, you're locking yourself in if you get approved at the state. If you move forward with this to have a study done in five years, that's going to tell you, yes, this is still feasible. No, this is not. And these are the alternatives. It will put this project to rest once and for all and the people that are against this project, they might get their answers, saying this is not feasible anymore. This feasibility study is going to include the most up to date EPA feedback about the wetland crossings, the state, the Commissioner stated on the meeting, most of you have watched it, and they're going to look for EPA feedback. If EPA says you're not going to get a wetland permit crossing for such an impact, case closed, one of the gentlemen, I think, stated at the beginning about widening Wason Road. I don't know what the answer is. We're not going to get into it because we don't know. That's what we're hoping the state comes in and figures this out for us. The million dollars, it's not taxpayers money from Hudson if he doesn't get used, well, if it is, if it is, it's going to be spent another community, there was other ones out there waiting in line. Mr. Groth added, its federal money. Mr. Dhima reiterated that saying, its federal money. It's going to get used no matter what. So to think like, oh, well, we're not going to use it, we're going to save it. You're not saving anything. You just basically pushing this money to another community to find their answers on traffic. Everyone is dealing with the same thing. The decision is yours. There's no decision being made at the state. If you don't want to move forward, that's fine. But we have to understand we have a problem and we need to find a solution or we don't. And we need to stop talking about, you can't have it both ways. We have a problem, but we want to do a feasibility study. There was a lot of discussions about HLC and the other projects. We're not here for that. We're here to deal with one thing and right now is what these people even behind me has been asking for 12 to 16 months. Find a solution. What are you doing about it? That's all there is. You did it with NRPC. You've been asked about this today. But doing nothing is not going to solve anything. We know that much.

Chairman McGrath then said, Mr. Ulery, did you want to add something? Mr. Ulery replied, yes, just to follow up after the meeting on what it was, we sat down and I contacted the Commissioner. The Commissioner made a suggestion as to the best way to proceed. At this point Chairman McGrath addressed the crowd in the room saying, hold on a second. Any conversations... we're trying to get this meeting over with, so please don't have side conversations that are going to interrupt everybody, including me, because I'm having a hard time hearing. So go ahead. Mr. Ulery continued saying, thank you, Madam Chair. So the Commissioner said this would be the best way to proceed based upon the information. Then all of your Reps met with the Governor. The governor said, Yep, I agree. This is the best way to proceed with the... this is the area. This would be the best thing. Understand

that the 10 year plan has a set value of money. It's going to be appropriate for this now, may or may not be spent. It doesn't. It'll go back into the general fund if it's not spent. But there's a finite amount of money that goes into the 10 year plan every two years. Well, anyway, it's called the ten year plan, but it every two years, it's another 10 years. So the vehicle, if you will, to get this feasibility study done to determine whether or not that first arc is viable, was chosen as the place for the feasibility study. That's all it was. It's a feasibility study. Nothing more, nothing less. Can it or can't it not be done? That's what been being asked.

At this point Chairman McGrath said so I think a point needs to be made here to why the state is involved is because Lowell Road from is it from the Presentation or Market Basket, right in that area that it becomes a state owned road down to the down to the Mass state line goes up Dracut Road from Dracut Road, all the way to the town line. And that's and that is a state road. Mr. Dhima then added so is 111 all the way down to the Burger King as well. Mr. Groth added, technically the entire routes are state owned. The urban compact area, which are the closest ones to the core of town, are town maintained. So that's the difference. Mr. Ulery, from the back of the room said, and that's a contract. The compact is a town gets to pay, the state gets to pay them, to take care of it. Chairman McGrath added so also, in addition to those roads, the Sagamore Bridge dumps and that's owned by the state, and it dumps traffic onto Lowell Road, which is a state road. So that's why that's why they're involved. If they if it wasn't a state road, we wouldn't have the state involved looking at traffic issues for us, right? Is that right? Mr. Ulery replied, Yes, Madam Chair. And it should be recalled that that's the second Sagamore Bridge that's existed there. This isn't the first bridge that was built. The first one was way too small for existing traffic. And also the traffic studies do exist that were done by the DOT, which I don't have the exact numbers. I think it's about 143,000 vehicles on Lowell Road when there's only something like thirty four or forty three hour I, there's only tens of thousands of vehicles registered in Hudson, so the majority of traffic today doesn't belong or doesn't stay in Hudson. They drive through.

Selectman Morin was recognized and said Just one clarification from did you say all the state reps met on this? Mr. Ulery replied, with the Governor. Selectman Morin asked, every one of them and we've got what, 11 12? Mr. Ulery replied, well, one of the reps from Pelham didn't attend. She had a Committee meeting that day. Selectman Morin then said but what everybody else is a whole, our Reps met and moved forward with this. Ok. Mr. Ulery replied saying yeah, because the fact of the matter is this is a situation that affects the state and it affects the it's original impact as everything else was. Selectman Morin added, that's the key word, because I heard that come up earlier, a regional thing. So obviously all our reps in this region met on this. So it is a regional...Mr. Ulery then said and Nashua's is interested in it. They didn't want to get involved because they didn't want to be associated with conservatives Hudson.

Chairman McGrath then said, we'll bring it back before the Board of Selectmen now. Selectman Roy then Selectman Gagnon. Selectman Roy said he had his hand up first.

Mr. Gagnon said thank you, Madam Chair. So a question to you guys. You know, I was aware of multiple public input sessions for the New Hampshire Dot's 10 year plan at the end of last year. In October, there was six, seven, eight different input sessions, as well as a month long email open to provide your input. Why wasn't any input from anyone provided at that time when the when the public was open and they were taking this these recommendations and requests? Mr. Dhima replied, there was no discussions from the Town. We were notified at the last minute by Selectman Ulery. That was it. There was no, we're not aware of any public input or any of that. And did not participate in any of that. Selectman Gagnon replied, okay, I realize. He continued on saying, and so on a different topic, the build grants for the circumferential highway/ Hudson Boulevard. It was denied twice, costing the taxpayers \$50,000 in application fees. Mr. Dhima replied, it wasn't denied. It wasn't granted. So we did not qualify for that grant. It wasn't like, I think that's two different things, but we applied for it and we did not get it twice. Selectman Gagnon asked, and do they give us any kind of reason whatsoever? Mr. Dhima replied, I looked into it. It's they set up committees and basically we made it through the first tier, which is basically like, Yeah, this is a good project and then didn't make it

through the second tier or third tier. Once it got to the third tier then he got to the Secretary of Transportation to make the decisions. It was my understanding at the time that was very political. So you would not get a grant from the State of New Hampshire at all. But then you will get two federal grants for Maine at the time for something that had nothing to do with traffic as far as I'm concerned. So one of those things we did not get in twice.

Selectman Gagnon then asked and do you have any knowledge of why you know this circumferential highway/Hudson Boulevard has been on the New Hampshire Dot's 10 year plan for many years, but it was always said it wasn't going to be funded. And then most recently, as of last year, it was dropped. I talked to Mr. Minkarah about that, and he said, yeah, they just ended up dropping it. Do you know why they dropped it from the previous 10 year plan? Mr. Dhima replied, there was no funding for it. It's that simple. The ten year plan gives the state a projection as to what they can do. That doesn't mean they have the money and they're going to do it. What you will see is if you do your research and go over the 10 year plan for the past 20 years, you're going to find out plans that have been sitting there for 20 years through the 10 year plan. All they're doing is they're moving the needle further and further out. So just because it's in the 10-Year Plan doesn't mean it's going to get done. 10 year plan means that they're going to try to do that or at least project or put some funding for it. That's it. There's no funding right now to do this project as far as I'm concerned. What we're trying to do is basically get them come up with a solution, whatever that is. That's what the feasibility study is. I think this is the first time at the Town of Hudson has had the state of New Hampshire come in with federal money to say, yes, we are going to look to what the alternatives look like. This could come in saying this is not feasible anymore, we ask the EPA and the said no and that's it. Case closed. We close the books once or for all. We never have to deal with this again and we start looking at other options. Whatever the other options is. That is an outcome of this. I think everyone is treating it as, oh, they're coming in to build the highway. And I don't know that. this would be a ticket out for the state saying, Yeah, we bought it...Selectman Gagnon interjected saying let me clarify, I completely agree. And so to my my last two questions here, I wouldn't be against an environmental study, of course I'm. But with that, I would really like to see, you know, for a million dollars. I'd like to see how that estimate came to be. Do we have a line item for why an environmental study might cost a million dollars? Mr. Dhima replied saying, If you watch the meeting, this number came and this question was asked at the meeting, and the New Hampshire DOT Commissioner said that a million dollars feels feasible to them based on all the prices they're seen out there from all the consultants and all the work that's being done. So what that means is that a million dollars is not going to be basically used to look at it and call it a day. They're going to look at everything, including what the actual wetland impact will be by square footage, by acre and get feedback from EPA. Having meetings reaching out to the town come up with alternatives. This is not something that they look at it and put an aerial together and call it a day. This is basically to get an official statement from them saying, yes, this is still feasible. No, this is not. We looked at it, nothing is going to work. There is a lot of money that will go into this from the environmental, wetlands, stream crossings, endangered species....Selectman Gagnon then said so I would be more this Sorry, I'd be for this study if I could see a line item, at least an estimate of where that came from. Mr. Dhima replied, as I said, it came from the DOT Commissioner. They deal with a lot of feasibility studies at the state level. They're looking at everything. That number, that's what they feel comfortable with and they're willing to go through \$250,000 in 2024 and \$750,000 in 2025. With that said, you're still going to have somewhere between eighteen months to maybe twenty four months to complete it. So the town best-case scenario, if this Board moves forward with this, you're going to get an answer to what things will look like in 2027, five years from now. But at least you're doing something about looking at some alternatives while just kind of not being able to do anything.

Selectman Gagnon replied saying understood. And last question for you if the Hudson Boulevard/circumferential highway is a potential on the map, Why would an an off ramp from the current route three to one of the larger developments proposed in town? Be on the on the docket for consideration as well? Mr. Groth replied, because state roads cannot exit into private property, is what we were told. Selectman Gagnon replied, Ok, I won't go into that today. Mr. Dhima continued speaking saying, so that it's basically with a development, right, that was vented out at the DOT. And

it's my understanding that while Lowell Road, River and Dracut, is state, I think the Turnpike Bureau jumps into the circumferential highway, whatever you want to call it, the bridge itself, it's the turnpike. It's not actually DOT. So the completely different bureau, but they're very strict on what governs ramp or not. And that was basically based on traffic numbers they assumed that they didn't feel comfortable doing a ramp because it's just numbers were not justified. We can agree with it or disagree with it. It doesn't matter. It was their decision. They made it. They reviewed the traffic model and that was the end of it.

The Chairman recognized Mr. Ulery saying I'm going to give you one minute. Mr. Ulery said that question was asked with the DOT Commissioner when it went up. The reason is highway design requirements and wetland impacts. You can't have an on ramp from Nashua at the beginning of an off ramp. You're asking for too many collisions.

Selectman Roy was recognized and said so I keep hearing you talk about they're looking at everything. So this feasibility will we'll talk about maybe widening parts of Lowell Road, maybe widening and fixing Wason Road? They will talk about those alternatives? Mr. Groth replied saying, what I would suggest is that if that is the desire of the Board, that that is part of the motion that if you wish to recommend a feasibility study with the caveat that other alternatives are explored, that would be my suggestion. Mr. Dhima added, you can you can have that language if you wish. I'm hoping that this is not as easy as this is not feasible. Best of luck. If it's not the answer, and it could very well be, what are what is the solution here? There's got to be something. They can't just leave us like this, right? Selectman Roy replied, right. That becomes the problem. The way this is written they are looking at one solution and that is all like nothing else exists. And that's the way that I read this and I could be wrong. But what I think everybody is saying here is, yes, we need a solution. It's not necessarily this solution. So what is every other solution that's available look like? Because there's nothing out there that says that. Mr. Dhima responded saying it's a perfect question. It's the same thing that's been said over and over again during the public input. And I'll tell you this if it comes down to that and all of us are still around in five years talking about this or any of these people behind us, you can make a decision then saying this is not acceptable to us, and that's it. Case closed, but at least you'll have an answer. Does that make sense? Selectman Roy replied, okay, and I understand what you're saying but it's only five years. I mean, if we'll if we want to look forward, we look way beyond five years just so we're. Mr. Dhima added, but at least you're doing something in the meanwhile, right versus doing nothing. Selectman Roy replied saying and I understand that. She then went on to say so you talked about we would get a statement that said that this was feasible or not feasible. Who would so I guess there's two questions. Who would issue that statement? And who does the study? Mr. Dhima replied to Selectman Roy saying, so the state will hire a firm they would be running the entire project. I don't know if we'll be able to participate or not. That's part of the negotiations that could be part of this motion tonight. But the state, it's my understanding they'll be running this and they'll provide us with basically feedback or conclusion on this matter. The study will be done by whoever they pick. It could be a low bid or it could be CBS you know, yeah, professional engineer in New Hampshire, wetland scientists. It's going to be everyone involved. Chairman McGrath then said, can I make a suggestion that we defer this item to next week? We have a meeting on the 1st and you (Selectman Roy) can write up what you'd like to see in the motion. You (Selectman Gagnon) can write up what you'd like to see in the motion. You can do the same and Selectman Morin. I'm not going to participate in it because I'm going to be up here running the meeting, but we're spending a lot of time on this and we're not going to spend another half hour trying to conjure up a motion. We can do that next week. Unless you want to stay here tonight. Selectman Roy replied, I think it's important enough that it should be resolved tonight..Chairman McGrath then said to Selectman Roy, then start writing because I'm not staying here until two o'clock in the morning. That's what we used to do in the old days on Planning Board. We had two o'clock meetings that would end.

Selectman Morin was recognized and said when is this going to the next level? Because we may have to get this squared away tonight? Mr. Ulery, from the back of the room said, I'm not sure what it's going to go to the House floor, probably first week, maybe second week in March. Selectman

Morin asked doesn't it have to go to the Senate first? To which Mr. Ulery replied, no, it does not. It goes to the House first. Then it goes to the Senate and then comes back to vote. Selectman Morin replied, okay thank you. Selectman Roy said is there...can I just ask Mr. Ulrich, is this something that's happening on the twenty sixth? Selectman Gagnon then said fourth. Selectman Roy then said oh the twenty fourth. Is there a hearing or? Mr. Ulery replied, I'm not sure. I don't know where that's coming from. Selectman Roy said yeah, I thought I had read it somewhere, too. I don't I don't recall. Selectman Morin said I thought I did too, that's why I asked. Mr. Ulery replied, they haven't voted on it yet.

Mr. Dhima then said our approach was the second this was entertained and it was no guarantee it was going to entertain or not, basically put emotion together, I think the decision was made Thursday or Wednesday or Thursday. I forget. The next day a memo was put together to present to the board to figure out which way you want to go. There's no decision made at this state. You don't have to send a letter out if you don't need to. But I think it's important based on what I heard at the meeting that a position is to be made by the Town. That's why you...

Selectman Morin was recognized and said this may be for the Engineer or Mr. Ulery also, where we've got to we can take a yes or no vote tonight because it still has to go through your process. And when the state's going to issue a contract, would that be the time to make a motion of what we want? Mr. Dhima replied, I think that's probably for the State Rep, because I'm not I think there will be the first one to be contacted versus the Town. It depends. The state is weird about how they do things right. It's my understanding they're going to run with that. I would like to say that we'll participate on it and they're going to run it by us, but I'm not sure. I think Mr. Ulery can probably answer that better than I can. Mr. Ulery replied, I think the Town Engineer has given a pretty good analysis, but what has to take place is it has to go through the legislative process. Oh I almost said a bad word... legislative process and then it comes back and goes forward. Now, if in your motion of support of a feasibility study that's wide open, you could say Board of Selectmen support a feasibility study and request to be part of that study. Done. There's your wording, Madam Chair. Chairman McGrath said it's not my wording. Selectman Roy also said t's not my wording.

Mr. Dhima then said if the Board at least agrees in principle, the feasibility study is warranted and we should pursue this. This is not this is state money for once, at least since I've been here with the Town in seven years, they actually come up and say, yes, great. If not, then there's obviously no point of discussing this. I think working out the detail on the motion itself. It could be next meeting. Either way, the sooner the better, obviously. But we do have emails. We can't send it to them electronically. But I think it's I think it's important at least to agree on principle if we want to move forward with the feasibility or study whatever those alternatives are. As far as the language goes, I think Chairman McGrath is right. I think you guys can draft it. Whoever wants feel comfortable with it, it's more work. I'd rather not do it. I'd rather have the Board do it and then see if we agree on that.

Selectman Guessferd was recognized and said Ok, so a couple of things here, first, I do appreciate your attendance making yourselves available, Selectman Morin, you making yourself available on short notice to go up and support this. Mr. Dhima replied, we did not support it. Selectman Morin also said we did not support this. Mr. Dhima said we attend it. Selectman Guessferd clarified saying to listen to the arguments. I'm sorry. I misspoke. Ok, exactly. To go up and listen to what was being said. Ok, what was being said was all about the circumferential highway, all about Hudson Boulevard. Whatever. The comments you made most that the Representative made were specific to that alternative. Ok? That's one of the reasons why we have so many people here tonight. Ok? Some of the statements that were made, it's we've, you know, some of the citizens said, you know, certain things about the time it takes to get from here to there. Some of the other things, and one of the statements that to me was the most egregious was the fact that Hudson, all of Hudson wants this. That was stated. And that's not it at all, because I heard from a lot of people tonight and they are part of Hudson and they don't want this in any way, shape or form. I would probably, from my own perspective, be remiss to not listen to them. Ok, in terms of my own personal, my own, I won't say personal, my own feelings about this as a selectman. That's that is my where I'm sitting right now.

Now, if there is a way to make a motion that would be acceptable and much more acceptable to the citizens of Hudson, I would be, I would be open to that, but right now, I'm not hearing that from my perspective.

Mr. Dhima then said so I just want to say this again, this is not about the circumferential highway. This is about finding a solution. It might be, it might not be it. And I've said this and I want to say it again. We have to look at the good, the bad and the ugly here unfortunately. It's one of those things, but I do believe that the state, it's their responsibility to fix this. They caused it, not the Town. So they for once are coming up with the money to figure this out. And you, as a Board need to take advantage of this. I. And if you choose not to follow this, that's fine too. But I feel like, we felt like, some kind of position needs to be made by the Town because this might not come back again. This might be done after this.

Chairman McGrath then said go ahead, Selectman Roy, then Selectman Guessferd, Selectman Gagnon in that order.

Selectman Roy said so a couple of things to Mr. Guessferd's point all we've heard in this memo from the presentation that was made to say was the circumferential highway. It appears that no one is looking at any other alternative, right? Mr. Groth replied well, that's why the conversation was had about the Hudson Boulevard. What we've suggested is the Board consider as part of motion to support the feasibility study is to include other alternatives. That's what we've put in this motion here, and that's what we've been voicing. Selectman Roy replied saying well, no, this just is a feasibility study which then that which then can be limited or expanded at the state's discretion, not at our discretion. And I think that's really where I where I where I differ with this right? Mr. Dhima replied, the motion, for the record, does say to support the feasibility study and to send a letter of support to the New Hampshire Senate for the study and or other alternatives. That is the motion presented to you tonight, which you don't have to entertain. But that's what it says and other alternatives. Selectman Roy responded, and I can't I can't support it as it. I would be happy to listen to somebody a more solid motion that talks about what those alternatives are, because that's not discussed here at all. There's one alternative. Mr. Dhima replied, but we have to start somewhere. If they agree to do a feasibility study, we have to take that, especially if it's on their dime. That's the bottom line. Anything else you'll have to pay for? That's what it's going to come down to. Selectman Roy replied, again, I can't, I can't support it the way it is. Mr. Groth then said if we had the alternatives we wouldn't need the study. Selectman Roy replied, if I could just finish my comments here, I agree with Mr. Trost when he called this a zombie project. It's like sixty three years this has been floating around and this community has never had the will to do anything about it. So I don't know why it keeps getting revived or whatever you want to call it, because anyways, I'm done.

Selectman Guessferd was recognized and said I understand your arguments. I, you know, I do understand what you're saying. But everything has been represented in terms of one thing, one solution. And I get I get it. Now I'm also hearing there's no funding that this study wanted to be done for five years if we even if we got it going now. Mr. Dhima replied, Mm hmm. So what's the harm? I'm just I'm just bringing it up. Selectman Guessferd replied, there's another piece of this. I'm not. I'm a Hudson taxpayer, but I'm also a federal taxpayer, and I'd like to see my federal money my taxes go to things that are much more feasible I guess I'll say, better uses of that money. I don't think this is a good use of a million dollars of our taxpayer federal taxpayer money. I think there's probably other projects in the state that could better use that and that would benefit the state as a whole. Mr. Groth replied, we don't know what those projects are. And the point of not having alternatives is the study hasn't been done. That's the point of the study. You laugh at me (Selectman Roy), but that's the point. Selectman Roy then said because its one alternative, that's all that seems to be discussed is one alternative.

Chairman McGrath asked, Selectman Guessferd are you done? To which Selectman Guessferd replied, I am done.

Selectman Gagnon was recognized and said thank you, Madam Chair. I could be wrong. But what I've been confirmed is that there's a Senate session this Thursday on House Bill 2022. The House has already approved the amendment that Representative Ulery has proposed. And to me, listening to everyone in the room, it sounds as a communication gap because I think I was been informed that the amendment that was called out by Representative Ulery, actually calls out the Circumferential Highway or the Hudson Boulevard specifically. Whereas you gentlemen seem to be saying that it's a feasibility study and you're making it wider. As I stated before, I could get on board with a feasibility study, as the residents have requested in the past for the Hudson and the region. But again, today I can't support it until I see a line item for what the million dollars is for. And then I would like to see that the amendment in the House bill reflects what you guys are telling us.

Mr. Dhima said, Madam Chair, I got the amended HB 2022 today. I just want to read it for the record, so everyone understands. Project Restored the project named Hudson, project number 42108 is restored to the It's restored in the scope of work and amended in a 10 year transportation improvement plan to conduct an analysis to evaluate the feasibility of constructing a road between Route 3A and Route 111 southern portion of the circumferential highway. With the engineering total of \$250,000 in fiscal year 2024 \$750,000 2025. Funding source federal funds. That's it. Selectman Gessferd replied, that's exactly what we're talking about.

Selectman Morin was recognized and said I got a question again for the Planner, engineer or the State Rep. This money, because it's coming from the state, is only going to affect state roads. Am I correct? So as soon as we get the PMA, it's a Town of Hudson problem. Am I Right? Mr. Dhima replied, it's before PMA. It's actually right by the flagstone. Selectman Morin went on to say yeah but once we get to that point, Hudson needs to spend the money to figure out an alternative. Mr. Dhima replied, we'll spend the money even on the state road after this. I mean, that's just the way I see it. Selectman Morin replied, I understand that. But what I'm trying to say is they're going, the circumvention highway is the property. They own that property and that was a question earlier that property has already purchased and its there. Mr. Dhima replied, Mm hmm. Selectman Morin went on to say Ok. And it's been there since 1959, but its state owned, so they're looking into a state road. They are not going to look...they're not going to look at Wason Road either, are they because it's not a state road? Mr. Dhima replied, there's a right of way issue that's taken there. I don't believe so. Selectman Morin then said that's a Town road. So if we wanted to look at other solutions that are on the town road, this town is going to have to pay for that. Mr. Dhima replied, I mean, they could propose it. But yeah, it's this is part of the feasibility study. These are all the things. I can't tell you, like which one they're going to look at, because if we did, we wouldn't be here, obviously. But yes. Selectman Morin then asked, over experience, right? Dealing with the state when I was on the fire department. Yeah. If it ain't a state road, too bad. See you later. And so that's what I'm trying to say. We have one option here that is a state problem. Who is going to do the state problem? After that all these people in this room can bring forward something. I want to give thirty thousand dollars to look at alternatives for our town. So why are we giving up a million dollars of free dollars but let the state do this state thing? And then we as a town can work on trying to put money towards looking at the town options Wason Road because we're going to foot that bill If we widen Wason Road, that's our baby. Whether anybody likes it or not, that is ours. They're not going to do that for us. Yeah, if we did County Road, you know, a cut off the Belknap Road, we got to widen that. That's ours, not the state. And that's what needs to be understood here. Any town road, we're paying for and you got to remember that.

Selectman Roy then said so if I could, but we would be paying the to have this built, even though it becomes a state road. My understanding of the funding model is that that the town would be funding this right. Selectman Morin said No, absolutely not. Mr. Dhima said no. Selectman Roy then said not the feasibility study, but the actual road. Mr. Dhima replied, No, no, that's I always said that they would never be fair for the town to pay to solve someone else's problem. That's always been said. Selectman Morin said and you got to remember when we said and see, here's the difference between the circumferential highway and Hudson Boulevard. We started the Hudson Boulevard thing and asked them if we could do it. They said, Yeah, off our plate, right? We brought that to them. They

didn't bring that to us. Now it's back to the state road. They are looking into the money. It will be them building it, if it got built. If it got built. So that's what everybody's got to understand. Everybody's making assumptions and we're looking at information on Facebook that is very inaccurate. You need to come and get what we're talking about here tonight. You got to understand there's a difference between state roads and town roads. We own the town roads, whether we like it or not, and if we're going to widen Wason Road, which is a circumferential highway. Now it's our bill.

Mr. Vurgaropulos, from the audience said, Madam Chair, its real quick. Chairman McGrath replied, it's got to be. Its 9:01, and we've got more business to do. You got to make it quick. Mr. Vurgaropulos replied, thank you very much. To my understanding, to pivot off what Selectman Roy just stated, how in you stated that the Town would have to foot the bill? I agree with Town Engineer, Elvis that the Town shouldn't pay for stuff that magnitude. It's crazy, right? But when I looked at when I was researching some of the stuff, you go to the town of Hudson web page and you look at the Engineering Department and you look at this project there shows the 2018 grant request and has the breakdown now. The breakdown shows twenty million dollars coming, twenty million dollars coming from the state. The other \$20 million would have to come from the town's residents. That's the way I understand it. Ok, I just wanted to make sure I was reading the information correct. Because you are right. Selectman Morin replied saying that was the old project. We were just Hudson Boulevard. You got to keep the two separate.

Mr. Vurgaropulos replied, I understand, I understand. And like you said, that there's a lot of misinformation out there. But the information that they're not very just separated readily on the site, but there is a whole so dedicated to that. So you see where the confusion is. Mr. Dhima replied, yeah. Two different things to your point, a Selectman, Morin said that was basically a 50 50. Not any different than an 80/20 right now. But basically, that is a completely different approach than what there's. Right now, which is basically just a feasibility study, a hundred percent supported by the NH DOT, using federal money, but absolutely no ties to the Town whatsoever. There's no construction phase, there's no design phase. That's it. And at the end of the day, there's no right or wrong answer. It's just a matter of which way the Board wants to go. That's it. There's no right or wrong here. It's just a matter of which direction you want to go.

Chairman McGrath went back to the Town Planner saying, so, Brian...Mr. Groth replied, thank you. What I've been trying to suggest and what we've both been trying to suggest is that the state has asked us for a yes or no, a black and white answer on this amendment. What we're suggesting is that the Board doesn't need to just comply with the yes or no. that a motion could be made a conditional statement that other alternatives are explored in the event that it's not feasible. Or however, you want to word that. Trying to give the board some leverage into expanding that to other alternatives.

At this point the Chairman said, so I'm going to make a statement. Because I haven't had an opportunity yet. It's true. It's 9:04 p.m. and I'm not going to take more than a minute. So all of the years that I've been working with Planning and in the town and working with the Planning Board and different planners over the years, I have, and I remember Lenny Smith, God bless him. The very first thing he said to me when he met me is about the circumferential highway and that that was coming to the town, that hasn't happened yet. I wasn't in favor of it then. I'm not in favor of it now. However, I'm just going to point out to everybody in this room, we, this board of Selectmen, we've taken an oath of office and we're supposed to be representing or supporting all of the residents in this town and the people in this room as vocal as they are. And I've seen them, you know, Mr. Crowley. Mr. Dobens, I'm getting to know their names. I'm getting to know their faces. But as often as they've come in, we haven't seen the other group of people and we don't know how many of them exist, that aren't that are in favor of taking care of the traffic problems and are in favor of the circumferential highway. I'm not going to go out looking for them, but I'm telling you that this is a small representation of the entire town and all of the residents that live in it. So we need to be careful about how we look at this and there may be other alternatives or other reasons that we haven't thought of. So. Although I'm opposed to it. As a representative of the entire town, I have to keep that that avenue open and be more, you know, willing to listen to other examples or other solutions that people may have. So its 9:06, are we done with this now for this evening or do we want to continue the discussion?

Selectman Roy was recognized and said I can't support this as this is written. As that amendment was read, I can't. There's no amendment I could make to this motion that would make that palatable to me. That amendment to the bill. Chairman McGrath said to Selectman Guessferd, so you you're not going to agree with...Selectman Guessferd said, I agree with Selectman Roy. Chairman McGrath replied, Yeah, I figured you would be. Yeah. Ok, so and you're (Selectman Gagnon) not in favor of it. Ok, so that's a two to three, the feasibility. This isn't going to go anywhere. Jordan, thank you for trying and I'm sorry for the residents that might be interested in a solution to the traffic problems.

Mr. Ulery, called out from the back of the room, Madam Chair, I did misspeak. I forgot to check the consent calendar. No one checks the consent calendar. It's fair to say. Oh, and by the way, the amendment is not just Hudson, there's several other items on the list. Chairman McGrath replied, okay thank you. She then said Ok, so everybody that was here for that project, you're free to go now. Chairman McGrath asked the Board, do you want to take a break? I'll call the meeting back to order at 9:15 p.m.

Selectman Morin made a motion, seconded by Selectman Roy to go back to the regular order of business. Carried 4-0.

During the recess Selectman Gagnon was excused from the remainder of the meeting due to a death in his family.

Upon return from the recess Chairman McGrath said I'm thinking about something that this gentleman said to me during the break. Yeah. I'm going to wait until you're in your chair. So before we take up the consent items, this gentleman in the front row made a point that to me during the break, we didn't take a vote on the feasibility study. So I think we should probably do that now. Selectman Morin said I'd like to hold that off because now we're short one, we're not gonna get an answer. Well, we will, depending on how it's worded. So I take that back. Selectman Roy then said well, as I said before, I wouldn't change the motion as it's written. It's nothing that was said that would make it make it palatable. So I mean, we could make the motion to close the record on it. The Town Administrator then said if it were two to two, it would fail. Which was, I believe, what would have been the result had there been three to two? Selectman Roy said, so I guess I'll make the motion to support the feasibility study and sent a letter of support to the New Hampshire Senate. Actually, I'm going to change that. I stand corrected. I will make a motion to not support the new feasibility sent letter and not study and not send a letter of support to New Hampshire, state the study and or other alternatives. Chairman McGrath asked, is there a second? Selectman Guessferd seconded the motion. The Town Administrator then said I was going to suggest if you make a motion and not do something and it fails, does that mean you do it? Selectman Roy said Ok, so I'll go back to the original motion.

The Town Administrator said, just keep it clean. Chairman McGrath said motion has been made and seconded to support the feasibility study, correct? Selectman Roy replied, Yeah. Chairman McGrath then said for the circumferential highway, all those in favor... let's do this by roll call now make it easier. Selectman Guessferd, no. Selectman Morin, aye. Selectman Roy, no. And Selectman McGrath, aye. So that's 2-2 motion has failed for lack of a quorum.

5. RECOGNITIONS, NOMINATIONS & APPOINTMENTS

A. Appointment

- 1) Conservation Commission - (2 alternate member terms to expire 12/31/22 and 12/31/23)

Carl Murphy

Selectman Roy made a motion, seconded by Selectman Guessferd to appoint Carl Murphy as an alternate member of the Conservation Commission with a term to expire 12/31/23. Carried 4-0.

6. CONSENT ITEMS

Chairman McGrath asked does any member of the Board wish to remove any item for separate consent. Selectman Guessferd made a motion, seconded by Selectman Roy to approve consent items A, B, C, D, and F. Carried 4-0.

A. Assessing Items

- 1) Elderly Exemptions: map 247, lot 108, 3 Elder Street; map 145, lot 009, 1 Bridle Bridge Road
- 2) 2021 Property Tax Abatements: map 161, lot 3-2 & map 118, lot 44 - 127 Barretts Hill Road & 38 David Drive
- 3) Elderly Exemption Re-qualifications: map 156, lot 039, 16 Phillips Drive; map 156, lot 006, sub 051, 9A Taunton Lane; map 198, lot 054, 1 E Street; map 178, lot 021, 79 Speare Road; map 167, lot 010, 9 Power Street; map 216, lot 018, sub 010 17A Holly Lane; map 175, lot 034, sub 016, 10 Pond View Drive
- 4) Disabled Exemption Re-qualifications: map 178, lot 013, sub 031, 87 Mobile Drive; map 177, lot 004, 20 Kimball Hill Road
- 5) Veteran Tax Credit: map 248, lot 091, 1 Crestwood Drive

B. Water/Sewer Items - None

C. Licenses & Permits & Policies

- 1) Raffle Permit - Trinity LLC dba The Bar
- 2) Raffle Permit - British Cars of New Hampshire
- 3) Outdoor Gathering Permit - Antique British Car Show

D. Donations - None

E. Acceptance of Minutes - None

F. Calendar

2/23	7:00	Planning Board - Buxton Meeting Room
2/24	6:30	Candidates Night - Hudson Community Center
2/24	7:00	Zoning Board of Adjustment - Buxton Meeting Room
2/28	7:00	Sustainability Committee - Buxton Meeting Room
2/28	7:00	Citizens Traffic Advisory Committee - BOS Meeting Room
3/01	7:00	Board of Selectmen - BOS Meeting Room

7. OLD BUSINESS - None

8. NEW BUSINESS

A. Open Space Resources

Chairman McGrath recognized Bill Collins, Conservation Chairman and Mark Beauchesne, NH Fish and Game Advertising & Promotion Coordinator. Mr. Collins started off by saying, Mr. Collins started off by saying, good evening, Madam Chair and Board members. It's a tough act to follow. Really, we were waiting in the green room for quite a while. The reason why I've come before you tonight is one. I'll start out by saying that the Conservation Commission is simply an advisory board to the Selectmen, Zoning Board and Planning Board, so we can't make any decisions or contractual decisions as far as I'm concerned in that regard. Recently, back in December, we had a group of concerned citizens approached the Conservation Commission about hunting at Musquash Pond and their concerns centered around some errant shots from a duck hunter. They proposed limiting hunting at Musquash Pond or doing away with it pretty much all together and, you know, keeping it as a wildlife sanctuary. But the Conservation Commission feels that it's still a viable piece of property for the sportsmen in the Town of Hudson to enjoy and go out and, you know, and take part in local hunting. The Conservation Commission is responsible for roughly a thousand acres of property throughout the town, of which probably six hundred acres is hunt able land. The thing we lack is, you know, signage and maybe a little bit of education to local sportsmen when they use these properties and after, you know, our meeting, we researched it, Selectman Morin reached out to Hudson Police Department. I reached out to Fish and Game to see if this was a habitual problem on town owned lands. And to be honest, we couldn't really find a whole lot. There were a couple of calls to Fish and Game dating back to 1999, and it was one complaint that was just this year about, you know, that errant shot. And it hasn't been a reoccurrence since.

Mr. Collins continued on saying, but while I was on the Fish and Game website and talking with members of the Fish and Game, I came across this land Operation Land Share program and I think I sent at least one little bit of information to Mr. Malizia and it was included in your packets. What this does is it provides resource to the Town for proper signage and things along that line. At this point, I'm going to turn over the conversation to Mark here, he's more of a professional here than I am. Mr. Beauchesne replied, thank you, appreciate that. So Operation Land Share is a cooperative program between the landowners, which would be the Town and the agency. The agency has a sign program that's associated with Operation Land share. The signs that we provide to the landowners address common landowner issues. Similar to what this gentleman spoke of, I can give you an example. Hunting permitted. Kind of talks about respecting the property, what responsibilities for hunters are, et cetera? But also, you folks have not just hunters, you have multiple people utilizing your conservation properties. It could be that these properties were purchased with the caveats to allow for hunting. I don't know that I'm not going to speak on that. That would be up to the Conservation Commission to discuss, but we provide these signs to landowner's conservation commission's towns like Hudson free of charge with the caveat that they leave a significant portion of their property open for hunting. We're not asking this, you know, for the whole thing. Obviously, there's some places that are hunting probably wouldn't be viable. Or maybe it's best that we keep some space that is advisable...

Chairman McGrath interjected and said advisable. Hunting shouldn't be advised. It would have to be advisable or...Mr. Beauchesne replied, well, it might not be viable, you're viable, viable, meaning that that there's other uses going on that piece of property. The Town Administrator added, like Benson Park. Mr. Beauchesne replied, yeah, like Benson Park. Yeah, there you go. But it's still conservation land. So that's where, you know, we want to make sure that where these hunters are approaching these properties, they may come in from private property, they may come across a piece of property or trail that you decide that you want to say this is a spot that we don't want hunting. We want to make sure this is a safety zone. That's where that safety zone signs come into play. So they're not to block off the entire thing just to make people aware. Most landowners would deploy them around

their house, their paddocks or places where they keep animals. The law states that you cannot discharge a firearm within 300 feet of an occupied dwelling when hunting. Now somebody can do that if they're not hunting, I don't care. But for the hunting purposes, that's what that is. That's a firearm and a bow and arrow. Chairman McGrath replied, I can tell you, I care when I hear guns going off that probably a little close to the three hundred foot mark. Mr. Beauchesne asked so is that hunters, madam chair or your neighbors? The Chairman replied, I have no idea. I have no idea what they're doing. All I all I know is that I hear guns going off and they're pretty close to where I'm sitting. I don't know if it's deliberate or not. Mr. Beauchesne then said so if, if it's during hunting season, it could be could be hunters. If it's not during hunting season, it could be recreational shooters, which we don't regulate. That would be up to the Town to regulate in regards to discharge and urban, compact, et cetera. But some of us hear that sound and hear the sound of freedom. So it's all perspective in regards to what we want to hear and what we don't want to hear. So we're here to say these signs are here to support recreational activities on Town conservation land and allow for multiple use. We're not just not just hunters, but also anglers where appropriate and other land users like hikers, mountain bikers. I don't know if you'll allow horses on your property, but those folks are out there too. So we provide the signs, you provide the nails.

Selectman Roy said so I have a couple of questions. Do we have the authority to sort of restrict so it's three hundred feet, yards, what did you say... Mr. Beauchesne replied, 300 feet from an occupied Dwelling. Selectman Roy replied, right. So if you take the like, can we adjust that in, for example, so that it's farther away? And then my other question is, can we get a little more specific about how errant that round was? Because really, it only takes one really errant round to cause a disaster? Mr. Collins replied, so I can speak to that. The Hunter was neglectful in maybe his shot taking his shot. It was duck season. You know, steel pellets, travel, you know, can travel quite a distance and you know, it was done maliciously? I don't think so. I don't think Hudson Police Department found that to be the case. Was it a crazy errant shot? Probably. And maybe his position was not very good in where he might have been standing. Selectman Roy then said I guess how close was that errant shot to a human being? Mr. Collins replied, I not even going to venture a guess. They reported to the Hudson Police Department pellets hitting their house or their car with apparently enough velocity that maybe scratch the car or caused some damage. I'm not again, I'm not, I'm not 100 percent sure of the whole case. Selectman Roy replied, okay, I understand.

Mr. Collins went on to say, the first, I just want to specify, we don't. Well, I can say that we don't allow pistol shooting or target shooting on Town property, so people are out jogging or using the trails. They're not going to come across somebody, you know, just target shooting in the woods. And if we do find evidence of that, we report it to the Hudson Police Department or our selectmen liaison right away and that gets taken care of. I think, you know, the goal is, you know, not to prohibit hunting. Obviously, it's a long standing tradition, right? You know, for everybody, what we have is development encroachment upon our open spaces, whether it be residential or business, and it is making it harder and maybe a little more concerning when it comes down to things like that. But you know, at the same at the same rate, we want to preserve the whole aspect of open space and. I've run into many, many hunters, I don't have any more myself, but I've run into many, many hunters who are very respectable of the land. They're probably more respectable than some of the other people using in the property. And, you know, we've never really seen an issue. This was a one-time occurrence. They I'm not sure if they know who it was directly, but the problem seemed to be rectified later on. You'll always have noise complaints. Duck season is duck season. You know, once they start flying over the waters, you know, there's a lot of shooting going on and stuff like that, but it's for a limited time. And you know, I really do believe people are respectful for that.

Mr. Beauchesne added so hunting season is a small portion of the entire year where other recreationalists can enjoy these pieces of property any time, even including hunting season. And that's why you know, what I'm here for is that, you know, we share the resources. We're not exclusive that it's just for hikers or just for mountain bikers that this this is a conservation piece of property. Conservation by defined is the wise use of the resource. You know, if hunting is a wise thing to

happen on this and safe thing to happen, then maybe it should happen. The same program helps identify or excuse me, helps address these concerns, so if there's an area where they need to put up the safety zone signs or make other users aware that there's hunting going on? That's what we do. You know?

Selectman Roy then said so, so just so I'm clear, is a business, does that fall into that occupied dwellings? Mr. Collins replied yes, yes. Selectman Roy replied, three hundred feet. Ok. Okay. Mr. Beauchesne replied Yeah. And that's archery. That's a bow and arrow. That's a firearm. So down here for deer hunting, you're in a shotgun territory, so there's no high powered rifles going on. So in regards to personal safety, I think you're more in jeopardy of the golf course, driving by getting hit by an errant golf ball than anything else. That's probably something you could write down, or she's going to write it down because that's just hunting incidences are very limited. What happens with hunting incidences because there's a firearm involved, the mainstream media and others grab a hold of it and they just never leave it down. I recently got a study in regards to all the hunting incidences that happened in New Hampshire over the past 30 years. We've been averaging six a year, and most of the time it's hunters hurting themselves. I fell out of tree stand. I cut myself, you know, cleaning a deer or whatever it may be. But there's a there's a large public misconception in regards to how safe is hunting. Yeah, I work for the agency. Yes, this is the thing I do, and I'm going to speak positively on it. But I encourage you to do the same and investigate just how safe it is instead of seeing one incident as the norm. All right. Mr. Collins then said so just to just to add a little more to that, like I said, the records I requested from Fish and Game date back to 1999 and the records that Selectman Morin requested date back 10 years. And in in that time span, like I said, only one incident was reported to the Hudson Police Department and a few minor incidences, you know, were reported the Fish and Game and that one incident to HPD was that that episode that happened in early, I think, early December.

Selectman Roy then said so I understand that and and I'm not necessarily opposed to this. In fact, I think if it makes it safer, it's probably a good thing to do. Right? My point was it really only takes one incident to to turn things really bad. Right. I'm just saying like when you're talking about firearms and weapons, it takes one incident. That's all I'm saying. I have a question. It's probably more for you (Mr. Collins). Is there a campaign or a notification process that you folks have about hunting season so that if somebody is using it for another purpose, they know to wear a vest or? Mr. Collins replied, yeah, during the during the fall, starting in September through late December, we normally announce that at every one of our meetings where, you know, hunting, it's hunting season again and make sure if you're out in the woods wearing bright orange for you, your pets, things along that line. We had a celebratory land acquisition get together a couple of years ago, and I brought it up at the end of the meeting, reminding people, you know, use the woods, use them as often as you want, just, you know, just be safe, you know? And as far as the hunters go, like I said, I've run into numerous hunters, especially in northern Musquash, and we've never seen any irregularities, any problems as a result of that. No, bullet holes in signs, you know, the typical things you might see sometimes when land is hunted. We've never really had a problem other than this one time. What really spurred this on, I think from the conservation aspects is, we don't want to limit our open resources to, you know, cross country skis and snowshoes alone. You know what I mean? We want it's an open, its open land. It's supposed to be utilized in a fair, fair way across the spectrum of users. And I think, you know, what we do lack is some signage at some of our kiosks in regards to this. And, you know, financially, I mean, it's not a big drain, but you know, if you start talking, you know, four or five hundred acres, you're posting stuff, you know, \$25.00 a pop at some sign stores, you know, it gets expensive really quick. The state offers a program, you know that like I said, I can't because I'm advisory, I can't, you know, without your permission, I can't sign on to this. And that's why we're here tonight. You know, we can better educate hunters, but we can also better educate the general public about hunting, too.

Selectman Guessferd was recognized and said have you have you considered also you say you do at the meetings, and is there something that you put up on on? You have a website, right? There's a

part of the town website. Mr. Collins replied, yeah, we have the town website. Yep. Selectman Guessferd added, hunting season, do you put things up there as well? And that sort of thing, a lot of people look at those, right as well. Mr. Collins replied saying so social media, of course, is always a big thing too. And you know, the Conservation Commission is taking a little more active interest in utilizing social media because we don't have local newspapers anymore. And really, it's tough to get word out in a lot of things unless people watch the meetings, read the minutes or they go to the Town website and they can say, go into the town website, sometimes it's pretty tricky to find some of that stuff. You know, we can put up a current event, something that's going to happen next week. But you know, you know, do we see, you know, hunting starts, you know, deer hunting starts September through the end of September or early October. You know, things like that now, but we do try to inform the public, like I said, every time we have a meeting or an event, clean up days, things along that line. And like I said, I've been using more social media to get the word out. We've been, you know, we've had a significant uptick in the people looking at the Facebook page that's out there, and I want to keep utilizing that to make people aware of these different things. And that's it, I guess tonight, really what I'm looking for is either a Town official to sign off on the program or, you know, be granted permission to do so, according to the rules that we have. Mr. Beauchesne then said one more point of two note here is that on every sign is this logo. And as the Department's shield, it carries a lot of weight. There's a lot of weight with the general public. It carries a lot of weight with the hunters. They see that they know that there's a cooperation going on with the agency. We stand behind that. So if there's a problem, we have resources to address that. Selectman Roy made a motion, seconded by Selectman Morin to allow the Conservation Commission to participate in the Operation Land Share with the Fish and Game Department. Carried, 4-0.

B. Water Utility Cyber Security Grant Application

Town Engineer, Elvis Dhima was recognized and said, Thank you, Madam Chair. Good evening, everyone. First item for you tonight is a water utility cybersecurity grant. This is basically grant money, ARPA money that the feds are sending down the pipeline. New Hampshire DES is getting a hold of it. They're reaching out to communities. We were contacted. It's basically an opportunity for the Town to have their Homeland Security or the third party. They'll be selected by DES to come in and do a stress test to figure out if we have any weaknesses and if we do, what can be done to do that? It's up to \$50,000. We already have done an internal required stress test by the American Infrastructure Act about a year ago, but we do have programs and projects in place, such as the antenna basically will allow us to do communication with our assets, not only through the wireless routers, but also radio frequency as well. So I'm hoping to use this opportunity to have them identify this need and use a 50 grand towards that project. With that said, I'll take any money, any money...(laughter in the room)after talking about A million dollars and giving it away or one hundred million, I apologize. Long night. I'll take any questions you might have. This is 100% funded by the state. There's no commitment or obligations by the Town. Selectman Guessferd made a motion, seconded by Selectman Roy to approve and authorize the Town engineer to apply for the Cyber Security grant. Carried 4-0.

C. Sewer Utility Cyber Security Grant Application

Mr. Dhima was again recognized and said thank you, Madam Chair. This is exactly the same thing, same amount, 50 grand. But this is really to our sewer utilities. Everything right now, as far as communication goes, for our day to day operation between the pump stations and our internal access to them, it's handled by a third party. Again, we'd like to have someone else come in, including Homeland Security, to look at that and the intent is to have a second means to

communicate if the wireless routers go down. Again, we're going to be pushing towards having radio backups for every single one of them so we can see what's going on with those facilities. They do not have any control system in there. So it's basically just view only. Do that for a reason. But then again, always looking for ways to improve that. So that's what this is, 100% funded by the state now. Partnership with the Town as far as money goes, so I'll take any questions, you might have. Selectman Roy made a motion, seconded by Selectman Guessferd to approve an authorized the Town Engineer to apply for a cybersecurity grant. Carried 4-0.

D. Hudson - Pennichuck Water Wholesale Water Supply Contract

Town Engineer, Elvis Dhima, was again recognized. Mr. Dhima explained, as you well aware, June 20, 2021, we had to disconnect one of the wells through the PFOS levels. Again due to the new requirements that were basically pushed down to us by the State, DES. We've been purchasing more water from Pennichuck ever since. Our contract with them, current contract we have with them expires in about two years, three years. So we have to start a negotiation. This event with the PFOS in one of the wells being offline, basically put Mr. Malizia and myself in a position to start negotiating a better price if we're going to continue to purchase additional water from them. While we deal with what we're actually going to do with the way with Saint Cobain. With that said, there was a long three months of negotiations back and forth. Legal was involved. The Town Administrator added, our Attorney participated just so you know this has been vetted. Mr. Dhima continued saying, the whole process was basically back and forth trying to get it. In a nutshell what we're dealing with is, if we continue with this contract compared to what we're going to be dealing with a new contract. If we purchase a million dollars million gallons a day, we're looking at about just over half a million dollars a year in savings between the current contract and the new one in place, based on a million gallons per day purchased at a minimum.

Mr. Dhima continued saying, so we think that's beneficial. The language from the previous contract is pretty much the same. We just have to fine tune it and clean it up a little bit. But that's basically in a nutshell, it's a two year contract with three, two year extensions. What that is basically is if we see that we bring the wells back and we want to purchase less water from Pennichuck, it gives us a mechanism not to lock ourselves in for 20 years, which is the current contract in place. With that said, I'll take any questions you might

Selectman Roy was recognized and said so I just want to be clear that this is funded out of the water fund, correct? Mr. Dhima replied, correct. 100%. You're absolutely right. Selectman Roy then said so will we be able to maintain our current water rates under this contract Mr. Dhima replied, as of now? Yes. This fiscal year, this upcoming fiscal year? Yes. Selectman Roy then said so I'm I'm I need a little bit of clarification. The memo talks about a million gallons a day. Paragraph 5A talks about 2.1 million gallons a day and then 7A goes back to one million gallons a day. So I just want to be clear about what we're purchasing here. Mr. Dhima replied, saying, I would start by saying that the contract is complex as it is for people that deal with this every day. But basically, what you're seeing is you're purchasing a million gallons per day at a minimum, but with a maximum of 2.1 million gallons. So they're basically saying we'll provide you a minimum of one million, but we cannot provide you more than 2.1, at least out of the EConnect crossing. We can push water from another crossing, which is on the Merrimack River in Litchfield. And that's what that is, providing a minimum and a ceiling and that ceiling, by the way, that was part of the original contract as well. Ok. So there's a limitation to what they can push to us.

Selectman Roy then said so then my I have just two more questions. One is any of these costs recoverable through civil action? So my understanding is there's some civil litigation going on about the PFOA, and I know that's kind of in the beginning stages in a very long time, the road. But can we recover some of these costs? Mr. Dhima replied, well, I can tell you, Mr. Malizia is keeping track of every single penny that we're spending and then some, including his time dealing with this. So yes.

The Town Administrator added, it is our intention that would be part of our plan. Mr. Dhima added, we've also been advised by the state to keep track of all the costs associated with everything that's basically triggering us to change our daily operations.

Selectman Roy replied, Ok.

Selectman Roy then said, and then I think my final question is probably more for Mr. Malizia, but do we need a non-appropriation clause in this contract? The Town Administrator replied, we've been under a water utility contract extension for 20 years. It does not have an appropriation. Just further state that the attorneys vetted. Should we have needed one, he would have advised to put it. So I don't believe so. Selectman Roy replied, okay. Seeing no further questions, Selectman Guessferd made a motion, seconded by Selectman Morin to approve the new Wholesale Water Supply Contract, as recommended by the Town Administrator and Town Engineer. Carried 4-0.

E. Fiscal Year 2021 Audit Report

The Town Administrator was recognized and said we got the audit report, which is, I think there was a copy of the report in the Selectmen's General Read, so you can all take a look at it. This also gets published in the annual report, just so everybody knows. So I think, Selectman Roy, you asked for it to be on the agenda. Selectman Roy replied, yeah, I just have some questions and some things that we might want to just consider how we're going to address in the future. So the gift card issue, I'll start, I'm on, I'm on Page three. The gift card issue, I'm guessing, we would be prepared to have an if that an unusual event ever happened again, we'd be prepared to have policy that that tracks that or whatever. Chairman McGrath asked, what is that? The Town Administrator replied, if you recall, at the height of the pandemic, the Board authorized the purchase of a gift card for all the employees. We distributed those gift cards, the auditor said well, you should really have them signed so that, you know, they got it. Selectman Roy said I think a tracking thing would probably be more appropriate than having somebody come in. You know that we issued this gift card to this employee kind of thing. I'm not so sure of having somebody. The Town Administrator added, I think it's probably tacky to have somebody sign. Selectman Guessferd and Roy agreed. The Town Administrator went on to say, but given that that's a fairly rare occurrence, I'm sure something simple can be put together. That's. I'll leave it at that because we don't do it that often. That was a pretty rare occasion. I will say this that typically you'll give an award to someone for their longevity. They're usually standing right here, right? I did talk to the Finance Director about these things.

Selectman Roy then said so the uninsured deposits, like so the way I read this and correct me if I'm wrong, is that we have money that exceeds the FDIC insurance limit in certain Institutions at certain. The Town Administrator said we had something that needs to be what they call collateralized. So we're going to need to speak to the Treasurer to make sure we have the appropriate levels because we need to make sure our money is insured. Selectman Roy replied right, okay, okay. And then I thought that we did this a couple of years ago with the reaffirmation of the town policy. The Town Administrator replied, so typically you've adopted or adopted certain policies like fund balance policy, investment policy. So both of us are a little puzzled as to what policies they're talking about. So the Finance Director will have a conversation to say if you want us to reaffirm policies that have not changed and we've been using, I guess we could do so. Selectman Roy replied, I think we've done that in the past, I vaguely remember something. The Town Administrator replied, I know we've done that 125 Cafeteria Plan. We do, we do other ones. But quite honestly, I can't tell you the last time we adopted XYZ policy, we have to specifically look at what policies they're talking about. I'm not aware that we were deficient in anything that required. That's like driven by the state. So the investment policy, what was the other one, the fund balance policy. There's some state guidance on those RSA. So we've done those on an annual basis. The 125 Cafeteria Plan, I believe, is a federal requirement. We've done that. Other policies, we need to find out what are the policies are you talking about? They found they have a town file that has our policies in it, and someone this year have said, Oh, we

haven't seen this one dusted off for 10 years. I'm making up a number. Ok, so you tell us which ones you think need to be reaffirmed. Selectman Guessferd said you've got to have findings?

Selectman Roy then said the reconciliation issue. The Town Administrator said we're working through the rest of that. I had a meeting with the Town Clerk, which is where that issue was. Those are, I think, proceeding along we are through. I believe I know we did at least one of the months, I think, is the second month we're finishing out. Selectman Morin said, we had that meeting the other day. Selectman Roy then asked, and so then is there a plan to make sure that those things continue to be done in a timely manner? Selectman Morin and the Town Administrator replied, yes. Selectman Roy then asked, what is the requirement? Is it quarterly or? The Town Administrator replied, you want to do it as often as soon as you can, but I would say quarterly would be a good goal to start with. Selectman Roy replied, Ok. That's all I have.

The Town Administrator then said but other than that, I think, you know, there's some pronouncements going forward. There's a lot of GASB, Government Accounting Standards Board. There's always some concern, some group that comes out with all these new standards you've got to comply with. The Finance Director will be speaking to the auditors to see how much that affects us. They notify us that these new standards were adopted. Some may not be applicable to the Town. Overall, though, I think the Town is still in a very strong financial position. Very healthy, fun balance 6.2 or 6.3 million for the general fund, the Sewer and Water have their own fund balances and I didn't see any other major, they didn't have any other major issues. Again, reasonable. And again, the report was in your general read. And it also gets published in the Town report so anybody can see it. Selectman Roy said I generally wanted to go over some of those Findings to make sure.

9. Remarks by the Town Administrator

The Town Administrator said just don't forget you have your next meeting is next Tuesday the 1st, as the election of the 8th, you will not be meeting that week. You'll be meeting next week. Just a public service reminder. Again, we have two polling places. If you're in Ward One, you'll be voting at the normal location Community Center. No change for those folks. For Ward Two, you're voting at Alvirne High School. The polls will be open seven to eight o'clock. It's the Town and School ballots.

10. Remarks by the School Board

Mr. Gasdia said jokingly said Madam Chair, I will keep it brief. 45 minutes tops. Get you out of here by midnight. I'll try to talk a little extra. So first, I think I need to first say Mrs. Putnam for saving the School District for the absentee ballots not being ready. But in all seriousness, the big news for us is the superintendent search. We have two finalists Dan Mullis, who is the current superintendent in Barrington, New Hampshire, and Garth McKinney, who is the interim superintendent in Nashua. Dan Mullis spent the day in Hudson today touring all of the schools. We had a public meet and greet at the Barnyard Cafe. We had a Zoom meeting, so unfortunately we took some of your TV audience away tonight at seven o'clock. And for this town and the staff, we're doing the exact same thing tomorrow with Garth McKinney, and we're hoping to have a decision made soon.

Next week is February vacation, so it's hopefully people can get away. It's a little more normal this year than it has been in the past couple. And with that March 1st, I will not be here, so I will miss that next meeting. And so depending on what happens at the election, this may be my last meeting with you, and I just wanted to take the opportunity to thank everyone around this table, including Jill and

Steve and everyone else for great partnership and, you know, looking forward to working with you again. But in the event we don't just want to say thank you back to you.

11. Other Business/Comments by the Selectmen

Selectman Gagnon: absent

Selectman Roy: So I two things. One, Candidate Night is this coming Thursday, February 24th at 6:30 p.m. in the Community Center. It's also will be on HCTV. You can you can submit questions to the Hudson Woman's Club if you have any questions for any of the candidates on the ballot. And so that runs from 6:30 to 9:00 and then on March 8th, again, it's two locations. Please do not forget to come out and vote. Please vote. That is all.

Selectman Morin: I've just got one thing. It concerns me greatly is the pounding that our Town employees got for some information that was not even close to being correct. Posts on Facebook started a frenzy and attacked our employees, and it could have been dealt with and it could have been stopped. But people chose not to do it. But we can get into that at another time. My concern is, as I mentioned tonight, the people that that had concerns with the Amazon project went to our Town Planner and our Engineer and got information every single time that they needed it. This Board, members of this board go to those two employees for information when they need it. But because one employee was asked by a representative, who is also a town resident who has that right to provide some information, we went into this frenzy and stuff got posted on Facebook and listening to the people here tonight, looking at emails that I have received and listening to all the things throughout the town and reading posts on the Facebook, and somebody said it tonight, and I wrote it down because it fits perfectly. Words matter. And it perfectly fit what happened from that, that Facebook post that had total erroneous information. And instead of that person or a person who could have corrected that issue did not, turned into a frenzy and our employees took a beating for no reason. I think it's wrong. I think it needs to be addressed and it will be coming up at a future meeting. Thank you.

Selectman Guessferd: The only thing I want to say is just reiterate about Candidates Night and also, you know, voting on March 8th again. Well, we could have say a multiple times between now and election, I'm sure. If you're if you're in one ward, you're voting at Alvirne, typically the northern end of town. If you're if you're in the other part of town, you're going to be voting at the Hudson Community Center. So we'll just see everybody come out. Let's get let's get the vote out. That's the bottom line. Chairman McGrath replied saying, I can guarantee you that I am going to be voting. I can guarantee you with that.

Chairman McGrath: And I have no comments tonight because it's been a long night. A lot has been said. I don't think I need to say anymore, so I'll save it for the next meeting, if you can. If you can come up and see me, I've got something for you.

12. Nonpublic Session- There was no nonpublic business this evening.

13. ADJOURNMENT

Motion to adjourn at 10:01 p.m. by Selectman Roy seconded by Selectman Guessferd.
Carried 4-0.

Recorded by HCTV and transcribed by Jill Laffin, Executive Assistant.

Marilyn E. McGrath, Chairman

Bob Guessferd, Vice Chairman

David Morin, Selectman

Kara Roy, Selectman

Brett Gagnon, Selectmen

draft

HUDSON, NH BOARD OF SELECTMEN

Minutes of the March 1, 2022 Meeting

1. CALL TO ORDER - by Chairman McGrath the meeting of March 1, 2022 at 7:00 p.m. in the Selectmen Meeting Room at Town Hall
2. PLEDGE OF ALLEGIANCE led by Benson Park Committee Chairman, Dick Empey
3. ATTENDANCE

Board of Selectmen: Marilyn McGrath, Bob Guessferd, David Morin, Kara Roy

Absent: Brett Gagnon

Staff/Others: Rob Buxton, Fire Chief; Tad Dionne, Police Chief; Dick Empey, Benson Park Committee Chairman; Diana LaMothe, School Board member; Jill Laffin, Executive Assistant

Absent: Steve Malizia, Town Administrator

Following Attendance, Chairman McGrath asked Police Chief, Tad Dionne, to come forward to be sworn in as Police Chief. Chief Dionne was sworn in and received a round of applause from all who were present.

Following the swearing in of Chief Dionne, Chairman McGrath recognized Planning Board Chairman, Tim Malley. Mr. Malley handed out a document to the Board. He then started by saying Mr. Malley said, so thank you. I just wanted to take an opportunity, at Candidate's Night there was a lot of questions about the master plan. I put together a timeline of where it stands. So I'll read through this, and then if there's any questions just stop me. So at the Candidate's Night, there was much discussion about the master plan. So who does the master plan? The Town of Hudson currently has a master plan that was adopted by the Planning Board in 2006. I have been told that our current master plan was a result of years of work by the Planning Board at the time, and it's a 231 page document. So this is some good news for you guys. The Board of Selectmen do not oversee or adopt the master plan so that's your get out of jail free card. The Board only needs to provide funding in the budget for the process, which the Board did approve \$25,000 for fiscal year 2021. I do want you to know I went back on some of the minutes back in 2012. It was estimated it was going to cost \$110,000 for the master plan. So apparently there was some ability by working with NRPC to get it down at a much lower cost structure.

Mr. Malley then went on to say, then I go into basically I just copied the RSA about the master plan. The couple of things that points I wanted to point out was the RSA doesn't give us a specific time for the master plan to be updated. There is a point in the RSA where it says it's recommended to be looked at every five to 10 years, but it's not a set in stone time frame for it to be reviewed. And the other thing is the master plan is not the zoning ordinance, so it's a guide to help create zoning ordinances, but it's not the zoning ordinance. It's basically just a guide for that development side of it. I'm not going to I'm trying not to read the whole thing, I'm just trying to do kind of the bullet points. So in 2011, in August of 2011, the Planning Board had on their agenda for review of the 2006 master plan. From what I was able to grab from the agendas in February 2012, it was talked about again and then in March 2012, there was a determination from Town Council at the time, which I believe was Attorney Buckley that it didn't need to be reviewed until after 2015.

Mr. Malley went on to say, so then from the planning department, we had a little upheaval with our town, a longtime town planner leaving, then we had a short term temporary town planner and that kind of all lays out that in 2018 Mr. Groth was brought on board. During one of my first meetings with

him when I became chairman was master plan and land use regulations were the two things that were his hot button topics. So, bring us a little bit more forward March of 2019, because the Board of Selectmen had done and put it in the budget and the budget was approved. July in 2019, when the funds became available under the new budget Mr. Groth started the process within NRPC in October of 2019. We held two vision sessions. 45 people attended. Then we turn around in November of 2019, we held two more. 41 people attended. And then throughout those months, we also had an online survey, and we only had 390 people participate in the online survey. So we were going good. And then in March of 2020 the world shut down. It kind of goes through, you know, Mr. Groth in September of 2018 had sent a memo over to the Board stating that the results of the public outreach were complete and published. We were working on draft chapters, but the review was really put on hold. We had some large plan sets, large projects coming into the community. We had a pandemic and we knew after the after all that we were going to have to get back into more visioning sessions because we anticipated we would start seeing some more activity instead of 41 people. Let's just go through where he had updated the Board of Selectmen and School Board in August of 2021. And during all of that, you know, we were still fulfilling our statutory requirements, zoning amendments, all those things.

Mr. Malley continued on saying, but the key point here is moving forward. We've already been having the discussions on moving this forward again. So from 24 through basically 30 kind of lays out what with thought process we've still got NRPC, they were willing to create and continue working on the project, work on getting some more in-person or virtual community outreach things going. Basically to finalize the master plan over the course of hopefully this year. Of course, we could have another lockdown and not able to do it, but that's kind of our intent. And then the one thing that was discussed was with additional outreach sessions there may be some areas that we want to do some more in-depth studies with NRPC and have them really look into. With an emphasis on population, housing, transportation, land and future land use chapters. But if we decide to go that way, I'm just going to fair warn you all, he's going to be coming in, probably looking for another \$5000 towards that project. I'm not requesting that or anything. I'm just a warning up there. So it's kind of hoping that this would kind of let everybody know that the process hasn't stopped, that the town of Hudson is in compliance with the RSA. We are planning to move it forward now that we can and I know you guys have been taking some hit on the campaign trail about it. So hopefully that get out of jail free card helps a little.

Chairman McGrath then said, Thank you. So they changed the law at some point because it used to be in order for us to be able to collect impact fees, which helps the schools, helps the town with traffic, roadway improvements, playgrounds, things of that nature, in order to be able to collect those impact fees we had to have a master plan in place. And it used to be every 10 years it had to be updated. I don't know when they changed it. At some point, they obviously I mean, you looked it up. Yeah, so and I don't I don't dispute that at all. I'm just saying that at some point along the line, they changed it from every ten years to 10 years, 15 years whenever you got around to it. So that might be the reason for the some of the comments that were made at the candidate's night, which I thought were grossly unfair. Mr. Malley responded saying, and, you know, in my limited research because once again I saw candidates and I just wanted to dispel any false giving's of the master plan. It's a very important guiding document. But even with the recommendation to do it every 10 years, well, as we know in two years, a community can greatly change. The city in Nashua adopted a 30 year master plan, so they're not going to look at it for 30 years. Chairman McGrath replied, well, that explains Nashua. Mr. Malley replied that does explains a lot of issues.

Selectman Roy said so, can I just ask the question. I would presume that that's a living document. So you say they developed this plan and they won't look at it for 30 years. I would hope that they. I would hope that when we when we do that, that we even if it's a 10 year plan, at some point, at some points during that 10 years, we're looking at that and seeing if those things still...Selectman Guessferd said, be adjusted, to which Selectman Roy replied right? Mr. Malley replied, yeah. So I mean, there's a lot of the master plan that is just basic data. Its data is data from the census. So there's a lot of parts of the master plan that that don't greatly change and alter. That is one of our hopes and intents, as once we get through this process, we can take in now a couple of years down the road as we're watching the town, maybe we open up some more vision cycles, maybe we take one chapter and just

kind of look at it. It is a document I'm not going to lie. It's kind of been put on the shelf since 2006. I received it when I was appointed to the Planning Board. I read it. I thought it was kind of boring and really didn't give much direction. I'm not going to lie, and it kind of got put on the kind of put on the back shelf. Well, so hopefully it becomes a living, breathing document.

Diana LaMothe, School Board Representative, was recognized and said I had the same reaction attending Candidates Night, and I actually was going to make a statement in the closing comments. Because I was a part of the Capital Improvement Plan development. I was one of the 40 something people that attended the public input sessions, and there is the capital improvement plan on the website, which I've mentioned before, is a great informational document and it is fluid. It's going to change. And that was actually an inspiration to get the school to develop a capital improvement committee specific to school only, which then of course, get communicated to the town. And I've given credit to Brian Groth for the capital improvement plan that he developed was a driving force behind what the school now has, which is on the school website. And I do remember the moment when the pandemic hit, and that's when everything was put on hold, so it was in process. The master plan update was in the process. And yeah, and the pandemic kind of changed a lot of things. So I just wanted to comment on that.

Selectman Guessferd was recognized and said I'll just make a brief comment. Get out of jail free card, I don't really like that term, but I understand what you're saying. I, you know, I think I mean, I look at it as, yes, we don't own, the Board of Selectmen doesn't own that plant, but I look at it as something that we hopefully have input into in terms of the vision of this town and that sort of thing so that we're somehow involved and not just kind of sitting back and and saying, not my job man, you know. So I will just say that, you know, as far as our job here as a board to kind of help kind of move that along and and so I do see that we have a little bit of responsibility with regard to kind of that piece of it. Yes, we don't set it. We don't necessarily own it ourselves, but I'd like to think that we're, you know, I don't know if you want to call it influencers or that we we have some input. Mr. Malley replied, yeah, I'm going to be honest and I don't know the answer, but I don't, I don't remember seeing anywhere in the statutes where it went to the Board of Selectmen. And it may. I may be a hundred percent...Selectman Guessferd interjected saying well, yeah, I mean, I'm not talking about a direct right, you know, a direct input to it, but...Mr. Malley continued saying between the liaison and you have a member on the on the on the Planning Board. Selectman Guessferd replied, right, right. Selectman Morin added, and we do have input as residents. Selectman Guessferd replied, right, exactly. Selectman Morin then said even if we don't do it here, you can still, as a resident go forward and state your opinion. Selectman Guessferd replied saying, right, absolutely.

Selectman Roy was recognized and said so I guess to Selectman Guessferd's point, I would hope it would be a little bit collaborative. That there would be some interaction between the boards about what support you need, what's going into it like even as a heads up kind of thing? So that to help go through the process. I mean, I guess as the leaders of the community, I would hope that this again, some collaboration.

Mr. Malley replied saying, as I said, I don't. I made this statement and I'm not sure I looked at the process. I don't remember how they did it back in prior to 2006. I do look at this room, I look behind me and there's quite a few members of those 41 people who are here tonight. So you do get your input also in that manner. So I'm not a 100% sure on that finalized process of how that goes.

Chairman McGrath then said so, so as someone that has served on the Planning Board for a number of years. I served on this board for a few years now. The Board of Selectmen role in this is providing the funds necessary. You know, if we have to, we have to hire outside staff. Seems to me that we've got someone upstairs that's working from NRPC and, you know, so I don't know if he's working on the master plan update or if he's working on something else but part of NRPC. So we provide the funds and the mechanism to actually be able to get this document done. As far as you know, you attended the visioning sessions, you didn't, I don't think. Selectman Guessferd responded, I did. I did. Absolutely. Chairman McGrath replied, I didn't, because Mr. Groth suggested that I not attend that. He thought that because I had a platform being this board that I might steer the applicant or the

people that were attending in a different direction than they wanted to go. I was mightily insulted by that. However, on my drive home, I started thinking about it and I thought, you know that that makes sense. And I was willing to step aside. And not attend the visioning sessions. So in any event, those are things that we can, as Board members, participate in. writing the document as Planning Board members, and that's all up to them. That's their role in the community, not only reviewing and approving plans or disapproving plans, that's their role as master plan update and. so in any event, I think that they I think that this this particular Planning Board has done a good job of that they may not be as timely as people want them to be. But according to your research, there isn't a timeline anymore. If the city of Nashua is not doing it for 30 years, 30 years, that's a long time to not look at your community and see what the residents want for development. It's pretty. I would call that pretty insulting. Mr. Malley responded saying, I was actually pretty surprised when I pulled it up that it was a 30 year master plan. There are other communities that are in the process that we are in right now, and they're dealing with the same thing. The town of Derry started their master planning process. They're just restarting it now that we're hopefully to a point where we can do those in-person meet and greets and getting all that vision going. I believe Litchfield is. So there's quite a few towns in around us that are actually the exact same process.

Chairman McGrath then said, so one of the things that I would suggest as someone that served on the Planning Board for a lot of years, I would suggest doing some visioning sessions again because the ones, the ones that were done, they're now kind of out of date. Mr. Malley replied, when we've already we've already talked about that. The fact that 2019 well, let's just go through it. We had a pandemic. We had some massive projects coming to town. There have been a lot of things that have changed in our community and we need to hear from the people again. Chairman McGrath replied, hopefully, they'll show up this time well, as opposed to and I would expect that the neighborhoods that have been so involved and showing up to Board of Selectmen meetings and giving public input, they're going to show up at these visioning sessions. They're going to participate in the process and encourage others to do the same. Because you can't do it unless you hear from the people that live in town and, you know, it's been, it's the same for voting. Mr. Malley replied saying, and as it was kind of a key point that really drew my attention and I knew what the attendance was because I didn't participate you know, I was one of the people actually working as one of the people writing on the board. Selectman Guessferd said, you ran my table. Mr. Malley replied, I ran your table. He then said the way it was going in 2019 approximately I'm just going to say 400 people were going to set the vision for the Town of Hudson's master plan. Hopefully at this point we will start seeing thousands of people come in and let's really get a good vision on the town and where everybody wants it to go.

Chairman McGrath then asked the Board, anybody else? The Chairman thanked Mr. Malley for coming in. Selectman Guessferd said, appreciate it. Really. Selectman Roy asked is there any more public input? Chairman McGrath replied, yes Kara, it is. Selectman Roy replied, you called him up. You didn't announce Public Input. Chairman McGrath replied, that wasn't public input. That was something else. So now I'm going to recognize public input. Anyone in the audience that wish to wish to address the Board on any issue which the board has control of at this time, come up and state your name for the record your name and address for the record.

4. PUBLIC INPUT

James Crowley, 4 Fairway Drive

I didn't realize the Planning Board Chairman would be here today. I'd like to go on record to say I've attended a lot of their meetings and I think the Planning Board has been knocking themselves out, working very hard for this community. I was going to, I don't know, as long as you got your master plan hat on I'd like to, I've been reading over the RSA's lately, not for the fun of it, but the applicable RSA's are 674:1-5. In three it says revisions to the plan are recommended every five to 10 years. It's not a cast in concrete thing. And then other sections, I don't really don't want to go into it, but it tells you how it's all laid out and it also goes through that says report to appropriate town

officials, which I consider sitting right here and it goes into detail, if everybody reads all these sections, they're supposed to be public input. Input from various town departments and NRPC. It really draws it all together. It gives you a roadmap of what's supposed to happen. And it's not something you do overnight. It's going to take a while to get through it all. But originally, the reason I want to, I just wanted to give you that. Make everybody semi comfortable.

Mr. Crowley went on to say, but originally I come here...I wrote this out. I would like to give the Board of Select an update on some discussions in the previous meeting. I have looked into RSA 674 this is subchapter twenty three on temporary moratoria and limitations on building permits and approval, subdivisions and site plans. It requires an enactment of an ordinance adopted by the local legislative body upon recommendation of the Planning Board. Ordinance requirements or statement of need for moratorium details, what is affected, written findings by the Planning Board to describe unusual circumstances, plus a bunch of other criteria. But on top of all that, the duration of this ordinance, if it's voted in as a whole one year. As so seems to be the earliest could be adopted as probably March of 2023 and it only lasts til March of 2024. That would be a tremendous amount of work and registered voter education, and I would think the likelihood of this happening in the short duration of the ordinance powers make this approach impractical. Historically, it appears the same conclusion was made by people smarter than me. And so in other words, I would say I'd take that off the table. Master plan is where you want to go.

Mr. Crowley then said I had a bunch of other stuff, too, but something if the Board allow me. Last but not least on Candidate's Night, I stated I would be willing to not approve a project, even if all the required documents were submitted. I'm trying for a three year elected Planning Board position. I know this is cause for concern, since elected Planning Board positions are no longer subject the Board of Select review and vetting. As a professional civil engineer, now retired, I am bound to use my knowledge to thoroughly review the quality of all reports, plans and plans requiring my approval. This is necessary even if the professionally prepared reports and plans have been peer reviewed by others. If I find deficiencies in these documents and plans, I can't ethically sanction or prove them. However, I will not put the Town of Hudson in a lawsuit position without extensive, considerable thought. I expect the Board of Selectmen Liaison, others, remind me of that, and they should expect any disapproval decisions made by me to be on solid, defensible grounds. Additionally, courts will not tell a developer to build whatever they want if the town were to lose a lawsuit. The contested points within the lawsuit would be what is overridden. The trick is to make the factual points of a disapproval specific and not just general indefensible quality. I love Hudson as many others do before making any negative decisions, if I'm elected, I will try to make them well known, if possible, to the public. If the Board of Select or town residents disagree with me before any voting on a project, please take the time to educate me. All I ask is if you disagree with me, please do it in an agreeably respectful way. However, I know even BOS or Board of Selectmen members are not accorded that respect on occasion. I've observed a lot of that. Also, please don't expect instant replies. I'm not too fast on a keyboard or in giving quick or short verbal replies. This speech tonight is an indicator of how I generally respond. I hope everyone exercises their right to vote for their candidate of choice, no matter who that may be. I also encourage everyone to make March 8th the largest voter turnout in Hudson. I mean, 14% is sad. Thank you for this time to think and allowing me to say my viewpoints. I will try to live up to what you want if I'm elected.

John Debuc, 11 Eagle Drive

Mr. Debuc began by saying, I wanted to cover a couple of things tonight. The first was something that was and we had there was a lot of discussion last week about that million dollars for this, for the study, the feasibility study. Something that Selectman Gagnon had asked was why an off ramp wasn't put in the plan for this development. And I think he was told that state roads cannot exit into private property. So for the most of the time that this project was in place, I attended most meetings. I spoke at a lot of meetings and we did a lot of research. And I remember talking about this quite often. And even Mr. Coutu had asked the question about, you know, will you put a road off into the

development? He was told, No, they won't. They won't do that. But when the 2007 Planning Board meeting GPI was the one of the earlier projects, GPI was the project designer and Mr. Ron Mueller was asked about that, and he said he was there was a design was still evolving with ongoing discussions with the state, DOT and the Planning Board's engineering consultant, stating that the New Hampshire DOT had set an access off the Sagamore Bridge Road was feasible so long as a developer could show a benefit. And that was brought up. So it's not that it can't be done, it's that it needed to be built into the project. And if a developer doesn't want to build it into project, it won't be done. But the New Hampshire DOT did not say that it can, that it cannot be done. So I just wanted to clarify that for the people that are here.

Selectman Morin was recognized and said let me answer your question. Two different projects. We have documentation upstairs from the Commissioner of DOT that says they will not build an off ramp for this project. No matter if it was approved or somebody could prove it or not. It was too dangerous. It was too much work due to the steepness of the hills and everything, they said. No. So that's a whole different project, a whole different thing at a different time. We need to clarify that. Mr. Debuc then said so I think that if that can be released in one of your... for the next meeting, so we can read this, because I know that when I was listening to discussions, they had asked the developer if they would try to develop this into the plan and the answer to Mr. Coutu was no, because Mr. Coutu was pointing for that. Selectman Morin replied, correct, because DOT, which again, it's a state road, it's not a Hudson Road. You got to understand that too. The commissioner said no, Mr. Debuc then said and I need to look at that and I'll readdress it. But for former project, they would. But this one, they would not. Selectman Morin said different commissioners. Mr. Debuc replied, different Commissioners and I can look at that.

Mr. Debuc went on to say, the second thing I want to, I want to thank Mr. Malley for update regarding the master plan. I think it's very important. You know, I really wish that in that year and a half that we sat in those meetings, we had a lot of people there that we could have thrown a few a few meetings in to look at the master plan. I think right now we have a captive audience with some of these projects that are going on. And you know, is there a way to build in some of this planning into the meetings instead of having every meeting? Look at these developments. And you know, if I had a way back machine, I would have asked for this, you know, instead of every two weeks looking at a single project for a year and a half, if we could have thrown in three master plan meetings, it would have been great because we had a captive audience and we have a captive audience right now. And I think this is the time to take advantage of that during these meetings when all these projects are going. I appreciate your time and I will look into that and hopefully I can get some clarity on that. Thank you. Selectman Morin replied, if you contact the Town Planner, he will give you the information. Mr. Debuc replied, he's great. Any time I ask him to something, he's phenomenal. He's quick and I really appreciate all he does for us also. Selectman Morin replied, glad you just said that. Thank you.

5. RECOGNITIONS, NOMINATIONS & APPOINTMENTS

A. Resignation

- 1) Benson Park Committee - Kevin Cormier, member term to expire 4/30/23

Selectman Guessferd made a motion, seconded by Selectman Morin to accept the resignation of Kevin Cormier from the Benson Park Committee. Carried 4-0.

6. CONSENT ITEMS

Chairman McGrath asked does any member of the Board wish to remove any item for separate consent. Selectman Guessferd made a motion, seconded by Selectman Morin to approve consent items A, B, C, D, and F. Carried 4-0.

A. Assessing Items

1) Certification of Yield Taxes Assessed/Timber Warrant: 58R Gowing Rd. - map 237, lot 032/sub 000

B. Licenses & Permits & Policies

1) Raffle Permit - Hometown Hero Outdoors NE Chapter

C. Donations - None

D. Acceptance of Minutes - None

E. Calendar

3/08 7:00am-8:00pm Town/School Election
Ward One - Hudson Community Center
Ward Two - Alvirne High School
www.hudsonnh.gov for Voting Information

3/9 7:00 Planning Board - Buxton Meeting Room
3/14 7:00 Conservation Commission - Buxton Meeting Room
3/15 7:00 Municipal Utility Committee - BOS Meeting Room
3/16 6:00 Library Trustees - Hills Memorial Library
3/17 7:00 Benson Park Committee - HCTV Meeting Room
3/21 7:00 Traffic Advisory Committee - BOS Meeting Room
3/22 7:00 Board of Selectmen - BOS Meeting Room

7. OLD BUSINESS - None

8. NEW BUSINESS

A. Town Newsletter

Selectman Morin was recognized and said two weeks ago, I was in an event and I had several residents again request a newsletter through the Town. They understand that we have all the information up on the website and we try to get out the best we can. But a lot of them want something they can sit and read, and we had actually had a very long discussion about it, how we would go about it, what we could include, what we can include. And they asked to bring it forward again tonight to see what we can do. Speaking with Lorrie from the Town Administrator's Office, she's willing to take care of that and do the newsletter because she had done what one or two

previously I believe. Selectman Roy said I think in a previous life, career or something. Selectman Morin continued on saying, and the way she was thinking about doing it instead of us mailing it out and a big cost, we have that, I can't think of what it's called, but your program, you sign up for different things through the town. You sign up for the newsletter. Sign up for the newsletter and once it's done, it automatically goes to whoever signs up for it. Selectman Roy then said can I ask a clarifying question this newsletter would be electronic? Selectman Morin replied, yes. Selectman Roy replied, okay, okay, I just want to make sure. Selectman Morin said it would be, you know, we have certain things you can sign up for and you get it automatically when something. Same thing. Discussion with Lorrie and because of what it entailed, and again, we have to we have to run this by Mr. Malizia. I had a brief discussion with him before I put it on the agenda tonight, so he was aware, but he's not going to be here tonight to see what, but she suggested, and I agree that we do a committee to try to figure this out first before we just throw something out there and set some limitations. When I was talking to the residents, I told them, we're not going to put, you know, Jane got an award for her gymnastics. It's going to be Town related stuff. It's not going to be a newspaper. And they were all right with that. It's just some of them need to read stuff instead of going online. So if the Board would agree to put together a committee and let this do this and let the committee come back and make a presentation to the Board and get this moving? That's what I'm asking for tonight.

Chairman McGrath replied, I think we're having an election next week and I think we should wait until after the election is over with because you never know what it's gonna look like after the election. Selectman Morin said it doesn't have to be done today, but it's something with the Board with the board back that? Selectman Guessferd replied, absolutely. Selectman Roy said yep. Selectman Guessferd then said we'd have to come up with things like how do we decide which goes in. Selectman Roy added, yeah, right. Who controls content, who you know? Who's actually publishing it? You know, doing the actual writing and stuff because that's the time consuming stuff. Selectman Morin then said you know, right and talk and you bring up a good point, Selectman Roy. Talking to Lorrie, if she's putting it on the website, she can just copy and paste it to this document, right. Selectman Roy then said she's not going to write every item. That's what I'm talking about. Who? How does how does that work? Selectman Morin replied, well, that that would that would be the committee that's to bring something forward to the Board. Selectman Morin then said I make a motion that we move forward with discussion of Mr. Malizia to form a committee to look into this and then to bring it back to the Board with the plan? This was seconded by Selectman Guessferd. Chairman McGrath then said, ok, motion is made and seconded any discussion? I'm going to abstain from voting because again, I'm going to state that after next Tuesday, the Board may look very different than the current makeup. And if one new member or two new members you normally, you know, count on, you know, those people that are going to be making the decisions, then so. So I'm going to abstain from voting, but the rest of you can go ahead. So my motion has been made and seconded. Carried 3-0-1 with Selectman McGrath abstaining.

B. Haselton Barn Discussion

Chairman McGrath recognized Chairman of the Benson Park Committee, Dick Empey, and Benson Park Committee member, Jack Madden. Mr. Empey started off the discussion by saying, this discussion we're bringing forward tonight all started at the deliberative session when a former selectman asked what the status was of the Haselton Barn and what we were intending to do with it. So we thought that we would come before you tonight and give you a little reminder of what's taken place with this barn. I'll have Jack Madden, a member of the Committee, read through this for you, and at the end of it, we happy to answer any questions and clarify anything that you are unsure about.

Mr. Madden started by saying thanks, Dick. The Haselton Barn is located on the southern end of Benson Park on the corner of Brush Hill Road and Flying Rock Road. This historic structure is estimated to have been constructed between 1850 and 1860, with major additions around the turn of

the century, the late 1800s, early 1900s. The barn is approximately ninety six feet long and thirty six feet wide. The barn is framed with native lumber, with mortis and tendon joints held together with one inch oak pegs. The structure is on the New Hampshire Register of Historic Places. In January 2009, the DOT transferred the Benson Park property from DOT to the Town of Hudson. Now the recent history in 2003 an extensive study was done to determine the condition of the structure. The study was updated in 2018. As of the 2018 report, the existing roof exterior was in very poor condition. The roof is comprised of one inch thick board sheathing, which was covered with a layer of wooden shingles. Then, over time, it was repaired with some metal sections on top of the wood shingles, and then one or two additional layers of asphalt shingles were placed on the structure. So currently, portions of the shingles are actually sliding off of the roof, and the roof has been leaking at a number of places in excess of three years. At this time, there's a significant amount of rot occurring in these areas, which will require replacement of the boards and possibly some of the underlying structural members. Now, in the spring and fall of 2018, we suffered several incidents of vandalism in the barn, including a small fire which was started on the wooden third floor. And that's the main floor of the barn as you come in the door off of Brush Hill Road.

Mr. Madden went on to say, in October of 2018 the DPW extensively re-secured the barn exterior to prevent unauthorized entry. And in December of 2018, we installed security lighting around the outside of the barn for \$1,875 dollars. There has not been any reoccurrence of unauthorized entry or vandalism since that time. So also in fall of 2018, we pursued an estimate to replace the roof. The solicitation went out to several contractors, but we only had one response. The only estimate we were able to get was a \$60,000 dollars to strip the roof down to the boards and install plywood sheathing on top of them and then asphalt shingles on top of that. Stripping the roof is required due to the instability and then the weight of the multiple layers of the existing roof. At this time, we also learned that an engineering study would have to be done to examine whether the structure could support the new roof and for the safety of the roofing contractors personnel. In January 2019, CMA Engineers did this report and they confirmed that the structure would support the new roof with only minor repairs. There was one cracked rafter and they would do this report for a cost of \$5,800 dollars. Also in January of 2019, the Board of Selectmen rejected the \$60,000 roofing project, saying that they would look for relief through Concord. Subsequent to the rejection, a meeting was held with the Board of Selectmen at the Barn with DOT and the Division of Historical Resources to seek financial support. At that time, the DOT and the DHR advised the Board of Selectmen that they could submit the request in writing. DOT advised, however, that it was highly unlikely that it would be accepted due to the agreement in the deed, stating that the town is responsible for maintaining the three historical buildings in the park. And those three are the barn, the train station and then the office and kitchen for Benson's.

So the buildings were to have been maintained and as equal or better condition than they were at the time. The signing of the deed back in 2009. So in the subsequent spring, the project was put on the town's capital improvement program. However, it did not make the cut for funding. So currently, the engineering report from 2018 is no longer valid through the passage of time, continue leaking, continued development of more rotting in the underlayment. Excuse me, on the boards and on the possible on the structural members. So the report would need to be done over now. Our cost estimate at this time for the roof repair is in excess of \$120,000 dollars due to the increased of scope of work that would be required through the continuing leakage in the roof and the ensuing rot, as well as the cost of inflation and building materials that has been occurring during COVID. Respectfully submitted Richard Empey, Chair, Benson Park Committee, and Jack Madden, member of Benson Park Committee.

Selectman Morin was recognized and asked what's the estimate for a new engineering study on top of that? Mr. Empey replied we haven't pursued that yet. I can tell you it was \$5,800 three years ago. I'm sure it's more now, and it probably will have to be a little more extensive because of the ensuing damage since it was done last time. A couple of things that came to mind as Jack was reading that first of all, back in the beginning, the DOT transferred the Benson Park property to the Town of Hudson. That was my quick claim deed. There are people that believe that somehow the state still owns a portion of this park or something of that sort. Fact of the matter is it is deeded to the Town of

Hudson. It is our possession with all the covenants that are included in the deed. It is not in any way, shape or form a state park or a state property.

Chairman McGrath then said except that they keep, they've got their thumb over the Town of Hudson because, you know, they keep threatening to take it back. Right? If we don't, if we don't put in certain buildings, if we don't do it a certain way, if we don't it, you know, it goes on endlessly. So I mean, they keep, they keep their thumb over the Town of Hudson. Mr. Empey replied, that's exactly true. Well spoken. The fact of the matter is, to my knowledge, at this time, the state has never actually spoken of taking back the property, which they certainly have a right to do, according to the deed. The hoops we have to jump through because it's a historic building that are controlled by the DHR, mostly somewhat extensive. For example, if we decide to do this roof and we pick architectural shingles for our replacement, that project would have to go to DHR and they have, I believe, 30 days to approve or disapprove our methods of repair. And they have the right to come back and say, No, you can't do it that way, we would insist on this way. And then where it would go from there is anybody's guess. As far as the state taking back the property, it says right in the deed that they must reimburse the Town for any expenses we have put into that park. This would probably be valued in the millions of dollars with all the landscaping work that's been done, the repair work on the buildings. And even though we haven't physically put that amount of money into the park, the value of the work that's been done is very, very extensive. If you went out and hired a landscaper to do that work, it would be in the millions. So the likelihood of them going that route, in my opinion, would be very, very slight because it's going to cost them a lot of money to take it back. And then what do they do with it?

Selectman Guessferd was recognized and said so, yeah, so I was going to kind of go there the value, so it's so it's clearly the value of what's been added, not the actual cost. It's clear in the in the, I'll say, in the contract and the deed. Mr. Empey replied, well, I'm not a lawyer and I'm not under contract with the town, but I think it's pretty clear in the deed that any improvements Uh, you know, again, I'm not a lawyer. Selectman Guessferd said I have one other question. So I live near there and I see that you didn't say we didn't say anything about the cupola. Mr. Madden replied, the cupola's awful. Selectman Guessferd said it's just sitting on the side is, is that is it, Is it, I would say that's got to be part of whatever repairs that we would do to it, correct? Mr. Empey replied, the cupola was removed in 2003 due to its extreme weight and the structure of the band. There was some concern that it might cave in so they removed the cupola. And in the reports that were done in 2003 and updated in 2000, what was it, 18? They addressed that the cupola alone has a price tag on it of about \$95,000. But the thing to keep in mind here is the deed says equal or better condition than the day we bought the park, which was in January of 2009. In January of 2009, that cupola was in poor condition. It's still in poor condition, you know, but we are obligated to restore it to the \$95,000 dollars price tag. No, I don't believe so because it wasn't in good condition when we took it. We only have to maintain equal or better condition. And there actually was a report done, a firm was hired and a report was done to the condition of these buildings on that day. And as I understand, there was some discrepancies in that report and it never was formally accepted by the Town, and I'm not sure about the DHR as to the condition of those buildings.

Mr. Empey then said, so this discussion I had not intended to ask for anything, ask for any action on your part at this time. I think it was responsible to the form of selectmen and to the town to bring you up to date as to where we are today, and I guess it's up to you to decide what action we should take. I predicted on the day that we walked away from that meeting. I said to a selectman that this project, if it is not done, a portion of that roof is going to be in on the floor in five years. And I believe as of today it's right on schedule. You don't have any more than another two years or so before that roof's going to cave in in a section. Not the whole roof. I intended to take some pictures, but I went over there to do it and found it was all covered with snow, so that was not too productive.

Selectman Guessferd then asked, I see a light on in there sometimes is it is that part of the security? Mr. Empey replied, there should never be a light on inside the barn. Selectman Guessferd replied, there is. Mr. Empey responded saying, that tells me somebody's been in there and forgot to shut it off or whatever. The exterior of the barn has motion detector lights that only work at a certain light level. They won't come on during the day just right after dark or at dusk. Last I checked on them and it's

fairly recently, they're all in good working order, but I kind of find it interesting that you saw lights on. Selectman Guessferd then said, toward the top, actually. That's yeah, it was weird. I mean, it's been on. They were on. I don't know if they're on right now, but they've been on the last several weeks. We've seen the light on in there. Mr. Madden replied, it might be some kind of a reflection of the way the exterior lights are bouncing off or something. Selectman Guessferd said it could be, yeah. Mr. Empey added but if it's on at night, what would reflect? Anyway, something I'll take a look at it.

Chairman McGrath then asked, so what are you looking for, Mr. Empey? Do you want us to tell you to? What would you like us to do? Mr. Empey responded saying I don't think I really have an answer to that question. As you know, in the past has been a great deal of discussion as to the value of the barn. And if you put X number of dollars in the barn, what does it gain us or what is the value in doing that? All I can state is what the DHR says we are supposed to do. If you said to me, I want to spend a half a million dollars and restore a portion of that barn, I guess my answer to you would be, and what are you going to do with it? So this is the dilemma. It's a beautiful, old, historic barn. It's in much better shape than the exterior indicates. A walk inside that barn is a little surprising. But that said, how much money do you spend to maintain a historic structure that nobody has an answer of how we get a value back from that? What do we do with it? There's been talks about a farm museum, a venue for different public events, all those things. And the biggest problem going forward with that barn is there's no water, there's no sewerage. If you were to use it in any public way, you would have to make it ADA accessible. You would have to probably put in a sprinkler system and then, you know, heating insulation, air conditioning, you know, depending of course, what you use was you'd have to put a lot of money into that barn to make it something that was really usable. If anybody has a great idea, I would certainly entertain it. But in the years that I've been around the Benson Park Committee, we've never come up with a viable answer to what to do with it, to make any kind of a public thing out of it other than perhaps a farm museum. You'd probably spend in excess of \$2 million.

Chairman McGrath then asked, so if you don't upgrade it or maintain it in any in any fashion and it becomes one of these barns that you know, starts to topple over. What is the state apt to do about that? Because I know, I know, I'm not imagining it because I've heard it many times where the state was going to take it over again if we didn't do something with, you know, whatever it was that that was being proposed. So, you know, if we let the barn topple over collapse upon itself, what would the state do then? I mean, would they would they come back in and say, well, you were supposed to maintain that and we're going to do, you know, we're going to fine you a certain amount of money or we're going to take Benson's back because you didn't live up to your agreement? I mean, what are they going? What exactly is going to happen? Mr. Empey replied, I don't think anybody has an answer to that, including the state. I don't think they'd know what to do. They'd have a big discussion because, like I said, to take back the park, they've got to come up with millions of dollars and then they get the park back. They're going to get all kinds of noise from citizens about why did you close the park? How are you going to, you know, how would they maintain it? They certainly cannot run that park for the kind of money that this town does it. We maintain that park on a very short budget for what it is. So, you know, what do they do with this? They take it back, OK, if the barn collapses or if we don't meet our obligations to me and this is just me talking, I have no official position, no knowledge of any official position. Worst case scenario, I would think that they could come in do the work that should have been done and somehow back charge the town or fine the town or whatever for not doing what the deed said that we could do. But I'm sitting here guessing in front of you. I have no official knowledge of what would happen and nobody else does either.

Mr. Madden added, Chairman McGrath, in the in the deed, it requires the town to maintain it in a state of good repair. But there is no discussion anywhere in the document that I've been able to find where it says, are there any penalties for the town if the town doesn't live up to its agreement? The only thing is that the state says, yes, we can take it back. Chairman McGrath then said, so I just had a thought, which is why I'm smiling, because he would he would be, I think, more than happy to give us some inkling as to what the state would do in that's former Selectman Jasper. I mean, he's got he's got a great deal of knowledge about Benson Park and how we obtained it and what we have to do to keep it. So I would suggest that we set this Board, send a letter to select former selectman Jasper and see if he can at least give us some indication of what the state would do or what they

would want us to do and what we would be required to do. I mean, I can't imagine that that we as a community or the state, as their former owner, is going to let us allow that barn to collapse onto itself. I can't imagine that. And I imagine there'd be a lot of hoopla in the town from people that go to the park. They wouldn't want to see that either. I mean, I've been my parents are from Prince Edward Island, so I've spent a lot of time down there in the summers and in the fall. And it's sad to see a barn that in its heyday was a really pretty, pretty structure. And, you know, people really maintained it well. But when it's let, when it's allowed to disintegrate and fall in on itself, it's really quite sad and not pretty to look at. So I can't imagine that this community would want that to happen.

Selectman Roy was recognized and other than the roof, is the building structurally sound? Mr. Empey replied, the short answer is yes, with a few caveats. There's one roof rafter that's cracked, the engineering study mentioned this. That's a relatively simple fix. The problem area in that barn is its L-shaped that's a granary across the front wall, in the back corner in the valley with the two roofs meet is where the leakage is. Three years ago, the boards were wet. The roof boards on the inside, but they weren't rotted. Now they are. OK and there is some beams in that area, they're starting to look pretty soft. And again, I'm not qualified to give you a statement about exactly what needs to be replaced, but I'm smart enough to know a piece of rotten wood when I look at it. So anyway, that area needs work above and beyond where we estimated three years ago. The study that was done in 2018 mentioned this area, and I believe it said somewhere around \$8,000 to \$10,000 to repair that previously improperly repaired area and then the roof on top of that. But I would imagine, well I know the figures that he gave in that 2018 report very low today. And that's, you know, I mentioned in here that we went from \$60,000 three years ago to in excess of \$120,000 today. And I did a little seat of the pants research on that. We would need something in excess of 150 sheets of three quarter plywood to go over that roof. As one example, three years ago, that was a \$30 a sheet bill. Now it's in excess of \$65.00 dollars and going up rapidly. Same thing with shingles. And those are just basic items. So the inflation of the materials has been very dramatic in the last three years. And then on top of that, we have the addition of more deterioration and more work needed in those three years. So I feel comfortable in sitting here and saying you that \$120,000 will not do with that \$60,000 would have done three years ago, and I'd be absolutely amazed.

Mr. Empey went on to say, and there's another issue here, too, that comes to light. There have been some inquiries made through DHR about this roof by the DPW, and they found that DHR has contractors that are on their list that are qualified to work on historic buildings. Ok in contacting these contractors, today, I won't say today, a couple of months ago, only one replied and said they weren't interested. Another one said, we no longer do that, and the rest of them didn't even reply. So it is a real disconnect there. DHR said these contractors are approved to do the work. Then over here, these contractors can no longer do the work. So who the heck is supposed to do the work? You know, we have to go find an unapproved contractor and then get that contractor approved by DHR, and that's all part of submitting our design and what we're going to do. As I mentioned before, before you do anything, DHR has to approve what you're doing, so they know that you're not destroying historic portions of the building. This is this is not a simple, yeah, go ahead and do it. You know, there's a lot, a lot of issues.

Mr. Madden then said to follow up Dick and to get back to your question, you know, is the building structurally sound? Again, I'm not a structural engineer. That's not my major discipline, but it's a post and beam construction. The last time I was inside was 2018 when we had this other study done. And it is massive inside. But to Dick's point where we've got these leaks, no. You know, if you've got rotten wood against good wood, eventually you're going to get rotten wood and the beams. And that's the concern that the leakage has to be addressed. And then you have in doing the study, you're going to find out that there are going to be probably more than the single rafter that was in bad shape was, you know, three years ago. It's probably more.

Mr. Empey then said the other, excuse me, the other issue is this isn't the average roof. The terrain around the barn won't allow the use of aerial lifts to get up on the roof. It's going to have to be staging. The staging is going to have to be set up on uneven ground, which is a little bit more of a challenge. They'll probably need to be some grading work to get that staging stable for them to get

up there and work. Your average roofing contractor won't even consider looking at that barn. I only found three years ago when I went around trying to get estimates. I only found one person that would even talk to me about it. The rest of them said, No, we won't do that. We don't want to do that. We're not interested. We're too busy, you know, just no, because the time and effort to do that roof, they could go out and probably do four or five other jobs and make a lot of money on it. Whereas this job is going to be it's either going to be very, very expensive or they're not going to make much money doing it.

Selectman Roy said I had I had a follow up question. I guess I'll ask, but I don't know that I think you might have answered it. Is there anything we can do to, I guess, temporarily at least stop the damage that's happening? Mr. Empey responded saying, yes and no. Ok. The first thing that would come to mind is maybe put a tarp over the leak. Number one, the tarp isn't going to last because of the wind and weather. You know, first of all, you're going to have to get somebody to go up and put the tarp up. This isn't something the highway department can go over there, DPW, can go over there and just put a tie up on the roof. It's too high. It's too inaccessible for them to do with their equipment. So you put a tarp on the roof. It lasts you for three months, six months. What did you gain? You know, if you did a temporary patch on the leaking area paid somebody good money to go up there and put a decent roof on that section. It's, you know, it's like dominoes. You know, you repair this, the section right next was not much better than the section that has failed. And you're just going to go boom, boom, boom, boom down the roof. What are you gonna do it every two months, every three months, every six months. Go up there and do a patch. I would in good conscience and as a taxpayer in this town, I don't think I'd spend my money that way. I think that it's either do the roof and stop the leakage or take the consequences for not. Selectman Morin was recognized and said we've already done temporary repairs in the past, correct? Mr. Empey replied, oh yes, there's been there's been repairs done on that roof before. And one of the issues is that the repairs. We have between three and four layers of roofing on that barn and you talk to any roofer two's the limit. And the problem is so thick now that the roofing nails don't go through it all into the wood small enough to hold the shingles and the whole section of shingles where it's leaking, it's actually sliding off the roof. You know, it's all the all the simple little things have gone about as far as they can, you know?

Chairman McGrath then said, Ok. Anybody else have any questions? If not, I would suggest that DHR is it? That they be contacted and tell them that we're going to take the barn down or what a fall down and see what they have to say. Mr. Empey said, I guess my reply to you is, have the Town Administrator write him the letter? I won't put my name on that letter. Chairman McGrath followed up saying, it's, you know, you're essentially saying we're between a rock and a hard place. Mr. Empey replied, we are. Chairman McGrath went on to say we either have to do the barn over every inch of it because, you know...Selectman Guessferd said the roof. Mr. Empey and Mr. Madden agreed saying the roof, every inch of the roof. Mr. Madden then said, I mean the roof. We more or less need to do the right thing and fix the roof for you to decide whatever else you're going to do on the interior. Chairman McGrath replied saying so what may I ask you this? How are we going to hire to do that roof? Mr. Madden responded, well, that gets to be the problem, as Dick has noted it's a complex problem. It's not like hiring somebody to give you a quote to fix your roof in your house. I mean, it's a big structure, you know, varying levels of, you know, the topography outside.

Chairman McGrath then said, so let me just I'm going to say this. I give up because, you know, no matter what has been proposed, you know, it's either so to try and do the roof over, you don't have you don't have a contractor that you can hire to do that. If you want to do it some other way, there's no one to hire, they don't do that work anymore. So again, you know, what are we going to do? We can't hire anybody to do it. I think you two, I'm not sure that I'd put you up on a roof. Either one of you. Mr. Madden chuckled, responding, what are you saying, Marilyn? Chairman McGrath replied, I don't want to see you fall down. That's what I mean. Mr. Empey added, you ain't getting me up on that roof anyway. Chairman McGrath continued saying, no, but you know, it's every, every turn that we've tried to take with addressing this, we can't do it. And it's, you know, so go to DHR and find out from them if they have any contractors that they're willing to share and that they're willing to at least entertain whether or not they approve them as contractors that would be able to do that work. You know, it's we've got to do something, either something or nothing. So it's, you know, if somebody can't come up

with something, I'm going to say we're going to do nothing, right? Mr. Empey replied, that's the dilemma. We've kind of gone that route already. DPW contacted the DHR contractors that are on the list, and their answer was, all of them, was no. So is there contractors out there to do the job? I'm sure there's somebody out there will that'll do it for X number of dollars, but it might be five times what that route would cost any place else. You know, it's really a tough, tough situation.

Chairman McGrath then said so I just had another idea we're going to wait until Town Administrator Malizia gets back from his vacation and task him with this dilemma. Mr. Madden said welcome back from vacation. Chairman McGrath chuckling said welcome back and we'll see you when you go back to, you know, Florida for another vacation. Mr. Empey then said at this time, my feelings are that if we put a roof on that building, we're going to pay a lot of money. But it should make that building fairly stable for another 20, 25 years or more, which kind of gives us a little breathing room. Anything short of that is just let it go. You know, so you know, I don't know. I can't sit here and tell you, you should do this. You know, it's this is the point of this whole evening, this whole discussion is this is where we stand. These are the facts. And we've got to decide what our solution is going to be. Chairman McGrath replied, I think we're probably going to be hearing from former Selectman Jasper at some, because I'm sure he's watching this meeting and he'll have some idea of I don't know if he'll have an idea about maintenance of it or putting a new roof on if you can use asphalt shingles or if you have to put them put gold shingles on. I mean, you know, I don't, I don't know. It doesn't seem that anybody else knows. So we're wasting time here. And you know, it's just. I think that I think we're going to have to wait and when Steve comes back, see if he has an idea. And if he doesn't, then you know, maybe the new selectmen will have an idea. So I just I don't I don't know what else to do. So and we're going close to 8:30 pm now, and I was hoping to be on my way home at about eight o'clock. Mr. Empey followed up with saying, about the only thing I'm 100% sure of is it's not going to heal itself. Mr. Madden then said, with that thank you for your time.

C. Code of Ethics Report

Chairman McGrath said, we had two selectmen that were charged with an ethics violation. We've gotten the correspondence from the Ethics Committee and they found that there was no violation of the Code of Ethics. So that's unless you want to have a discussion about it further. I'd be happy to do that, but I don't know that it's necessary.

Selectman Roy said well, Madam Chair, I just want to state, for the record, that I've read and understand the requirements of town code 53.6 F, but I will point out that I was not noticed of either the complaint, nor the findings that appear as part of this agenda, denying me any due process. I am also aware of other ethics complaints involving elected officials that have not appeared on the Board of Selectmen public agenda. So it sort of boggles my mind about why this did. Chairman McGrath replied, can't answer you. Selectman Roy replied, well, somebody put it on the agenda, Madam Chair. Chairman McGrath replied, well I did. I did because I got the correspondence in the mail and it was addressed to me as the Chairman of the Board of Selectmen. And it's not just you, it's another selectman as well. Selectman Roy then said so and again, I know that there were other ethics complaints involving elected officials that have not appeared on the on the public agenda. So again, I just see it as odd, and I find it also interesting that I was never noticed. I had nothing to do with that. I don't think Selectman Morin had anything to do with that. Did you, Mr. Guessferd? Did you have anything to do with not notifying? I mean, none of us had that, we didn't have that ability at all. Selectman Roy replied, I'm just pointing out for the public record that I was not noticed and I was denied due process on this complaint. Ok, well, that's I can't help you with that.

D. Complaint by Town Employee

This item was not an agenda item. Chairman McGrath started by saying, So, OK, next up. This I'm going to take up one other item that we got in, I don't know if you got it or not, but it's a complaint by one of our town employees, Elvis Dhima, Town Engineer, violation of Title IV, public officers and employees. Please be advised that Selectman Gagnon has made a statement on social media regarding my position. His statement includes the following quote "maybe that the town engineer was saying anything he could to get us to agree, which wasn't true." Close quote per attachment, A. Selectman Gagnon, is implying that I was lying at that meeting. The rules and regulations listed above clearly state that matters such as this have to be non-public for the following reasons. Section 91-A:3 II(c) "matters, which if matters, which, if discussed in public, would likely affect adversely the reputation of any person other than a member of the public body itself, unless such person requests an open meeting. This exemption shall extend to any application for assistance or tax abatement or waiver of a fee, fine or other levy if based on inability to pay or poverty of the applicant." Mr. Dhima's correspondence went on to say, please be aware that as of as the Town Engineer, I am a licensed professional engineer in the State of New Hampshire and Mass, among other licenses, which are subject to renewal and regulated by rules and codes and code of ethics. Such accusations could result in review of my license status and investigation, which could trigger a suspension and monetary damage to my family and I. I demand an apology from Selectmen Gagnon and removal of any social media comments that could be interpreted as damaging to my ability to earn in my profession as a licensed professional engineer. Sincerely, Elvis Dhima, professional engineer, town engineer, member of Hudson Police Fire and Supervisors Association. So that was in our packets tonight. Selectman Roy replied, but it wasn't part of the agenda. And quite frankly, Mr. Gannon's not here....Selectman Guessferd interrupted saying he's not here to defend himself. Yeah. Selectman Roy went on to say, so I don't I don't know why that would have been read in public. Well, when Mr. Gagnon and you knew Mr. Gagnon was not here. Chairman McGrath replied, yeah, well, he chose not to be here. Selectman Roy replied, I don't think it was a choice Madam Chair. Chairman McGrath replied, I'm not so certain about that.

9. Remarks by the Town Administrator - absent

10. Remarks by the School Board

School Board member, Diana LaMothe was recognized and said I wanted to mention I presented to the Senior Center today. The school ballot and Police also presented the police warrant article, and it was an honor for me to go there. And I just I love the fact that there's a senior center in town and to be able to actually go there and there was a good turnout. There was like a dozen seniors who were present, engaged, and asked excellent questions. And so that's a good news report. And actually one of the seniors did mention she brought up the fact that a bus may be donated if it is accepted to help transport seniors to the senior center. And of course, you have to be a, you know, a certified driver of the bus, which is, I know in the proposed budget for fiscal year 23. So that was just some points that were brought up.

I do want to mention that the sample ballot, according to the printer, is in the mailing department and it will be dropped at the post office tomorrow. So if people are wondering when they are going to get their sample ballot, it should be in the next day or two. The school will also be posting on Facebook just a reminder to vote. There is a sign in front of the same building also that will continue to run that message with voting information and hopefully we get a greater turnout at the polls. And I will end there. That's all I have.

11. Other Business/Comments by the Selectmen

Selectman Gagnon: absent

Selectman Roy: So I am I have a couple of things. One, I find it unfortunate that Madam Chair chooses to try to shame a Board member that's not present. Second, and finally, I saw a Save Hudson New Hampshire post that has set a goal of 5,000 voters for this coming election next week. I hope I hope we exceed that goal. I won't be unethical and endorse any specific candidate, but I will ask you to please go out and vote on March 8th. That's all I have, Madam Chair.

Selectman Morin: I like to address a resident's email if you don't mind. I just got to find it here. So I received this email and we discussed this at the last meeting. That was a reference to what took place with the DOT Commission and how that all went down and we discussed that last meeting, but obviously the message didn't get out there. Or there's a resident that doesn't understand because this email was forwarded to the DOT Commission on February 28th. So I just want to address Kathleen Crowley's email so we can get this out again and make sure everybody's understanding. Her email goes on to say "Hudson Boulevard. This is a request to remove the feasibility vote from the agenda. Representatives Ulery and Rice, Town Engineer Dhima, Steve Malizia Town Administrator and Dave Morin did this without the knowledge or approval of the Board of Selectmen." Selectman Morin went on to say, now we had some discussion on this during the last meeting and I thought we had cleared it up, but I'm going, I'm going to cover it again. First of all, as we have talked to about state roads tonight, this is not our problem. This is a state land that's owned by the state land. It's not owned by the town. Two legislatures who brought this forward can do that because they're part of the state and they run things up there, not in Hudson. And as we've seen since this time, I have received numerous emails in support of this million dollars just to look at this study. I heard it at Candidate's Night that people are in favor of it, and I've also seen numerous posts on social media that people are in favor of this. So the next question was, again, we're being called on the carpet that we did something we weren't supposed to. Well, I can tell you and Mr. Debuc, I appreciate what you said tonight because you said Mr. Dhima has been outstanding in helping you. Well, Mr. Dhima was not only helping a resident...Mr. Debuc, from the audience said, Mr. Groth, not Mr. Dhima. Selectman Morin went on to say I'm sorry. I apologize. I apologize. He was helping...say that again. Did you say Mr. Groth? Mr. Debuc replied yes, as did Selectman Roy. Selectman Morin said, oh I said Mr. Dhima. Selectman Roy responded, he said Mr. Groth in his comments. Selectman Morin replied, you did? Oh, well, Mr. Groth was thrown in this, too. So it's still pertains. Ok. And he because he was brought into the original complaint and he didn't even go up there. He had nothing to do with this whatsoever. Ok. Mr. Malizia had nothing to do with this whatsoever, either, and people accused him. So I want to make that clear tonight. Second of all, Mr. Dhima, like he has done for all kinds of residents that have had issues and he does every single day with buildings, and anything was helping a resident who made a request and a state legislator that made a request. You how many times that we send stuff up to DOT on different roads? Let's take the Dunkin Donuts project, OK? There's nothing out there that we talk to you guys about, but there's another lane going in front of Dunkin Donuts onto the Sagamore Bridge. Nobody has any problems with that, but because some people don't agree with this study, we're going to blow this up into a big issue. Reference to my participation in this. If you watch the video, I sat there and said absolutely nothing. All I was there for to see what was going on because I was notified the night before. I had no idea what was going on. I went up to see. I did not represent the town of Hudson. I did not even represent myself. I sat there and said nothing. So people need to understand just because you don't agree, doesn't mean we can't do it. The Constitution of the United States says I can voice my opinion if I like whether people like it or not. Ok. This was nothing but a fact finding search because we had no idea ourselves what was going on. The legislatures did this, not us. That needs to be cleared. So I hope that takes care of any issues or

any misunderstandings that are out there. The Town of Hudson had nothing to do with this. State land. State legislators, not selectmen, not residents, not employees. Thank you.

Selectman Roy said Madam Chair, can I just ask a couple of clarifying questions? So cuz I did listen to the video. So when Representative Ulery was talking and referenced you as a member of the Board of Selectmen, you corrected him and said you were there as a private citizen, not as a member of the Board? Selectman Morin replied, he was speaking at the time. I did not, but I did not. I did not say anything so. Selectman Roy replied, and I understand that. So then let's talk about all of this, all this support that all of a sudden came in. I believe last week was discussed after duly noticed meeting, and there were, I don't know, approximately 30 people sitting there. Approximately 10 or so talked, only one of them spoke in favor of it. So, so I guess, you know, I get that they have a little a little buyer's remorse at this point. But you know, again, it was at the duly noticed meeting. And I have a question about something you said last week. And I just want to make sure that I understand it. People were talking about the circumferential highway and the Hudson Boulevard as interchanging things, just calling different names to the same project. Right? And you clarified that, if I remember correctly, and you said two things. One was circumferential highway was a state project paid for by the state. Selectman Morin replied, correct. Selectman Roy then said Hudson Boulevard was a local project and would be paid by the community. Selectman Morin replied that's how it was presented last year on the ballot. Yes. Selectman Roy then said Ok. But I think that as we said last week, words matter, right? Because the memo that we received from Mr. Dhima states that the DOT Director wanted to add the Hudson Boulevard project back on to the 10 year plan, not the circumferential highway, which means it would fall into the cost would fall to the community. Selectman Morin replied, not necessarily. That's just that's just assuming on your part. Selectman Roy replied, no, no, because that's what you said.

Selectman Morin then said, no, because if you I understand what you're saying. But first of all, we got to do the study first. Second of all, if they like the name Hudson Boulevard and that's what they call it, like the Everett Turnpike, then we're all good and they're going to pay for it. So that's semantics at this point. Selectman Roy then said no, again, words matter. And you explained that there were two. There were two different projects there. So again, I just want people to understand what we're talking about here. So either Mr. Dhima needs to clarify what he put in that memo or she's talking about putting the Hudson Boulevard project back on the 10 year plan as something that this community would pay for. Selectman Morin replied, again, I'm going to say...Chairman McGrath interjected saying, point of clarification first. Point of clarification. So are we talking about the letter that Mr. Dhima and Mr. Groth? Selectman Roy replied, the one that was presented last week. Chairman McGrath then said so that so it was the two of them that it wasn't just it wasn't just Mr. Dhima, it was Mr. Groth that helped. Selectman Roy interjected saying Okay, so well the authors. Chairman McGrath interjected saying so words matter. In in your terms, so make sure that you address it appropriately. Selectman Roy then replied, ok, so the authors need to clarify that because because quite frankly, it sounded like a shell game, right? Selectman Morin responded to Selectman Roy saying the State of New Hampshire wouldn't give us, wouldn't give us free a million dollars if they didn't plan on going through their road. And I'm going to say it again. We have the Everett Turnpike. We have this pike over here, but I will get it clarified for you, Selectman Roy. Make sure you get it. I'm all set thank you. Chairman McGrath then said you might not need to. Selectman Morin said you'll have it tomorrow. Selectman Roy replied, thank you.

Selectman Guessferd: Ok. I just want to clarify something else. You use the term, Selectman Morin, Town, getting the money. We're not getting any money. This is federal money they're going to spend no matter what. I just want to make sure because there's a lot of misconception out there. Selectman Morin replied, you're right. Selectman Guessferd continued saying that this is going to be money that we're going to have the authority to spend. Selectman Morin replied, we're not we're not specifically getting the money, but it is benefiting the Town of Hudson. Selectman Guessferd replied, I understand. But again, words matter, right? We all. So anyway, I just want to make sure it's clear because there's been a lot of social media and know about all this, and there's a lot of citizens that do

not have the right understanding of what this was all about. Selectman Morin replied, well, clarify that tomorrow for you.

Having said that, beyond that, all I want to say is get out and vote next Tuesday. Make sure you get to the right place. The cards went out. I got my card in the mail. Brightly colored neon cards, so make sure that you're voting in the right place. You're voting either at Alvirne or you're voting at the at the Hudson Community Center, so I hope to see you there. Thank you very much. That's it. I'm done.

Chairman McGrath: Ok, so I'm up next. And last. So I'm going to read a statement into the record. So I am supporting the police. And by the way, these are my comments, personal comments. I'm not speaking on behalf of the Board of Selectmen. I'm not speaking on behalf of anybody other than myself. So I am supporting the police facility expansion and renovation. This is an urgent need and the cost is only getting greater as more time goes by. Please vote yes for anybody that's watching this, please vote yes on warrant article nine.

Number two, I am fully supporting the election of Rich Weissgarber to the Board of Selectmen. Selectman Roy then said, point of order. Point of order. Point of order. I strenuously object to any member of this Board supporting a specific candidate from this dais. It's unseemly, and I think it's unethical. Selectman Morin then said correct me or not, you funded for Mr. Guessferd. What's the difference? Selectman Roy replied, what's the difference? I never said anything from this dais that before a town election, I've never said that. I've never used this as a pulpit to support a specific candidate.

Selectman Morin replied, I just wanted to get that out there. Selectman Guessferd said that's fine. Selectman Roy said okay, but it's unseemly and it's unethical, and it is different. Selectman Guessferd said and I agree with Selectman Roy. Chairman McGrath said of course you do. Selectman Guessferd continued saying, that there is no there is no reason for you to be endorsing a particular candidate, whether it's one of us or whether it's somebody else from this place. Chairman McGrath then said okay. Stop. Stop. I will. I'll stop this right now. Selectman Morin, could you take me to the public (input table)? Chairman Roy then said, well, the point of what a public input is over, Madam Chair. Public input is over. Chairman McGrath replied really? Selectman Roy replied yes. Chairman McGrath replied, I don't think so. Selectman Roy then said Bob. Selectman Guessferd replied, yes? Selectman Roy then said motion to adjourn. Selectman Guessferd replied second. Chairman McGrath then said, ok, so I'm going to finish my comments. Selectman Roy then said Motion to... a point of order. Point of Order. Point of Order. Chairman McGrath said to Selectman Roy, you can point of order all you want. To which Selectman Roy replied, I will point of order all night over you. I will. Because it's unethical and it's unseemly. Chairman McGrath kept speaking saying, I am going to read my last two comments. I will read my comments. Throughout this Selectman Roy was repeatedly calling for a point of order. Chairman McGrath continued to say I will read my last two comments. I will read my comment about Selectman....At this time Selectman Morin interrupted saying Selectman McGrath there is a motion on the floor. I have to agree with Selectman Roy. Chairman McGrath replied saying okay. So point of order. What is it? Selectman Roy said there's a motion on the floor to adjourn. Selectman Guessferd said adjourn. Chairman McGrath then said to adjourn? Okay. Motion has been made and seconded to adjourn. Vote carried 4-1 with Chairman McGrath opposed.

12. Nonpublic Session- There was no nonpublic business this evening.

13. ADJOURNMENT

Motion to adjourn at 8:41 p.m. by Selectman Roy seconded by Selectman Guessferd.
Carried 3-1, McGrath opposed.

Recorded by HCTV and transcribed by Jill Laffin, Executive Assistant.

Marilyn E. McGrath, Chairman

Bob Guessferd, Vice Chairman

David Morin, Selectman

Kara Roy, Selectman

Absent

Brett Gagnon, Selectmen

DRAFT



TOWN OF HUDSON

Recreation Department

12 Lions Ave • Hudson, New Hampshire 03051 • Tel: 603-880-1600



Agenda
3-22-22

8A

RECEIVED

MAR 17 2022

TOWN OF HUDSON
SELECTMEN'S OFFICE

TO: Steve Malizia

FROM: Chrissy Peterson

DATE: March 17, 2022

SUBJECT: Recreation Department Summer Staff Rate of Pay Review

I would like to be placed on the agenda of the next Board of Selectman Meeting to requests the board's consideration to increase the hourly rate of pay of our Summer Program Counselors and CIT's. The current hourly rate for counselor's ranges from \$10.00 to \$11.25 based on a step process, and \$8.25 for CIT's, (Counselor in Training).

Due to the Covid-19 Pandemic, we unfortunately had to cancel our summer program the past two year. Since then the world has changed including but not limited to, cost of living increases, price of gas, etc. As we head into our first summer reopening the program, I strongly feel that the time has come to review the rate of pay.

In order to attract applicants and secure staff, I am proposing the board's consideration to increase the rate of base pay to \$13.00 an hour for counselors with the opportunity to continue a step process allowance up to \$14.00. Additionally, I am recommending increasing the CIT rate of pay to \$10.00 an hour. Former staff sought employment elsewhere due to the programs closure, which results in us, reinventing the staffing wheel this year. It is imperative to offer a competitive rate to secure staff and important to put a price on the value of what the job entails.

Thank you,

Chrissy Peterson

Recreation Director

Agenda
3-22-22



TOWN OF HUDSON

Engineering Department



8B

12 School Street • Hudson, New Hampshire 03051 • Tel: 603-886-6008 • Fax: 603-816-1291

RECEIVED

MAR 18 2022

TOWN OF HUDSON
SELECTMEN

TO: Steve Malizia, Town Administrator
Board of Selectmen

FROM: Elvis Dhima, P.E., Town Engineer

DATE: March 8, 2022

RE: Construction Services Award for Transfer Station Upgrades

The Town transfer station is in need of upgrades related to compliance and efficiency. In 2020, Board of Selectmen dedicated \$40,000 to a master plan for the landfill, with Phase 1 including the design of a retaining wall, which will bring it up to code and improve safety and efficiency. In addition, the Board of Selectmen dedicated \$750,000 from the American Rescue Plan funds to implement Phase 1.

We advertised in the Union Leader and on the town website on November 26, 2021. On February 3, 2022 we held a mandatory pre-bid meeting and six parties attended. In addition, we sent the bid invitations to four different vendors. Our engineering estimate was \$750,000.

Our bid request included two alternatives, where alternative A consisted of all the proposed work to be completed by the contractor, and alternative B included a significant number of tasks and materials to be completed by our Public Works Department.

On February 24, 2022 we received one bid as follows:

	Alt. A	Alt. B
1. WPD Excavation, Hampton, NH:	\$899,435	\$699,820

After completing the bid evaluation, proposed work/tasks schedule and costs, it appears that an approximate \$125,000 increase is due to steel cost. We have engaged with the contractor and they are open to Public Works completing some tasks to reduce the cost of the project such as hauling material and the paving portion.

The contractor has agreed to provide credit up to \$30,000 if Public Works hauls fill in and out of the site. In addition, they have agreed to allow the Town to complete Item 403.11- Hot Bituminous Paving, which will reduce the contract by \$32,000. In summary, the contractor has agreed to reduce the bid amount by \$62,000 if the Town participates on the two tasks listed above.

The Town Engineer and Public Works Director's recommendation to the BOS is the third motion.

First Motion:

Reject the bid and rebid the project.

Second Motion:

To approve the contract for Construction Services for Transfer Station Updates to William P. David Excavation, LLC, for the amount of, not to exceed \$899,435, using American Rescue Plan Account #: 7203.

Third Motion:

To approve the contract for Construction Services for Transfer Station Updates to William P. David Excavation, LLC, for the amount of, not to exceed \$837,435, using American Rescue Plan Account #: 7203.

To reduce the cost of the project by utilizing Public Works to assist with hauling of material and completing the paving portion of this project using American Rescue Plan Account #: 7203.

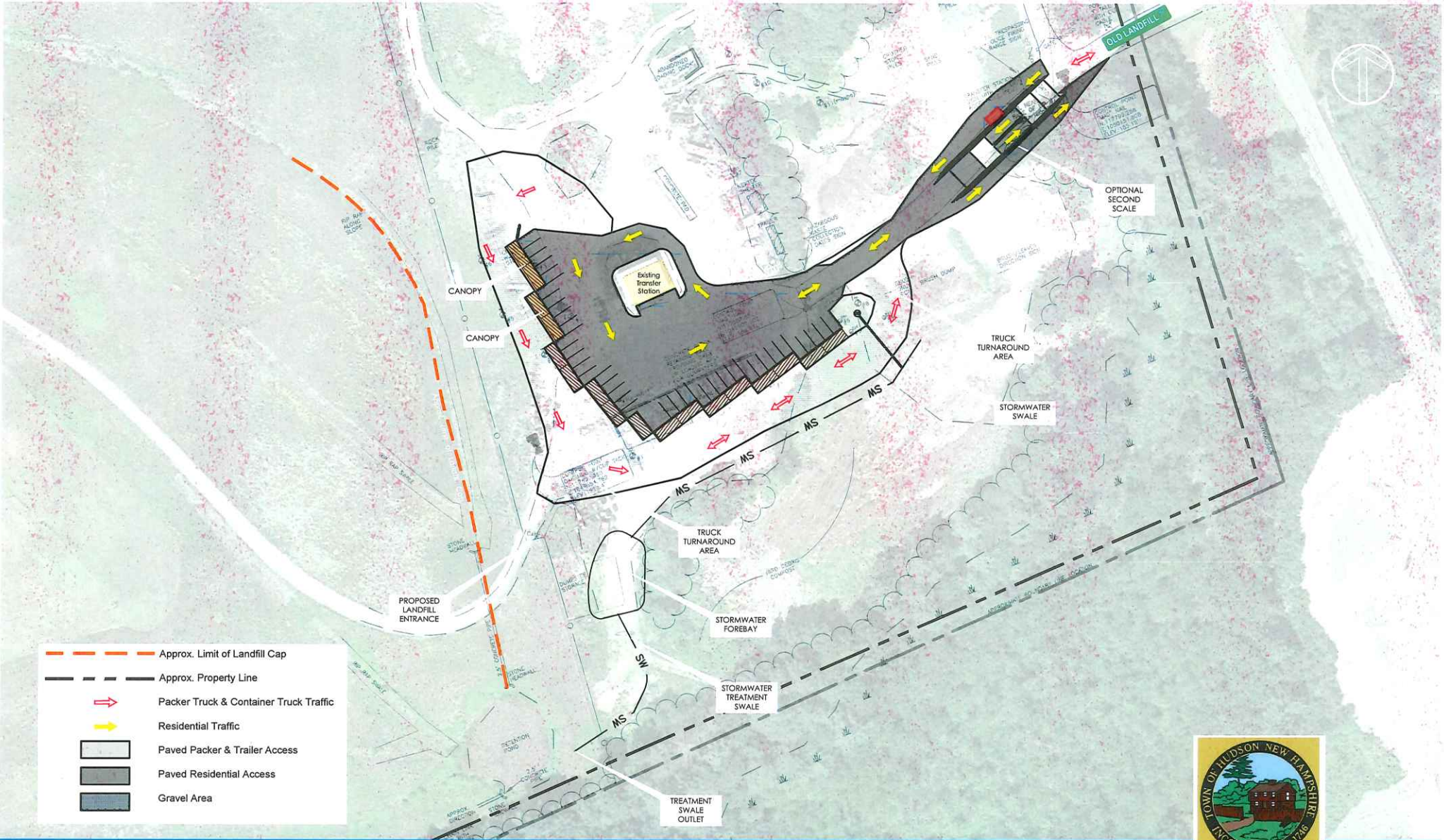

- Approx. Limit of Landfill Cap
- Approx. Property Line
- Packer Truck & Container Truck Traffic
- Residential Traffic
- Paved Packer & Trailer Access
- Paved Residential Access
- Gravel Area

Hudson Transfer Station - Hudson, NH
Scale Site Layout



CMA
ENGINEERS
 Portsmouth, NH
 Manchester, NH
 Portland, ME
 www.cmaengineers.com



Figure 1

WILLIAM P DAVIS EXCAVATION LLC

19 Lafayette Road, Hampton, NH 03843
603-944-5844

Mr. Elvis Dhima, P.E.
Town Engineer
Town of Hudson
12 School Street
Hudson, NH 03051

Re: West Road Landfill Improvements Project

Dear Mr. Dhima,

William P Davis Excavation LLC is pleased to offer the attached bid proposal per the specifications provided for the West Road Landfill Improvements Project location in Hudson, NH.

We are aware of the budgetary constraints and are aggressively pursuing this opportunity to work with the Town of Hudson on its development and construction.

After carefully reviewing the available project documents we are confident that our experience and knowledge gained on similar projects will allow us to aid in the design and provide potential savings to the Town of Hudson through value engineering.

WP Davis is committed to providing our clients with the highest quality workmanship at the most competitive pricing. After review of our proposal, we would respectfully request the opportunity to discuss the project with the project engineer and your staff to ensure we make every effort to bring this project in at the Town's budget and with the highest quality control possible.

I have included a list of our recent projects, our letters of reference from the New Hampshire Department of Transportation, our Bonding Agent and Banking Reference for your review.

WP Davis is grateful for the opportunity to bid on this work, and we look forward to the potential of working with the Town of Hudson and its agents on its completion.

Respectfully submitted,

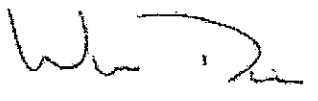

MANAGER

William Davis, Manager

PHILADELPHIA INDEMNITY INSURANCE COMPANY
One Bala Plaza, Suite 100
Bala Cynwyd, PA 19004-0950

Power of Attorney

KNOW ALL PERSONS BY THESE PRESENTS: That PHILADELPHIA INDEMNITY INSURANCE COMPANY (the Company), a corporation organized and existing under the laws of the Commonwealth of Pennsylvania, does hereby constitute and appoint Mark D. Leskanic; Bette A. Botticello OF THE TOWN OF NEEDHAM, STATE OF MASSACHUSETTS, its true and lawful Attorney-in-fact with full authority to execute on its behalf bonds, undertakings, recognizances and other contracts of indemnity and writings obligatory in the nature thereof, issued in the course of its business and to bind the Company thereby, in an amount not to exceed \$50,000,000.

This Power of Attorney is granted and is signed and sealed by facsimile under and by the authority of the following Resolution adopted by the Board of Directors of PHILADELPHIA INDEMNITY INSURANCE COMPANY on the 14th of November, 2016:

RESOLVED: That the Board of Directors hereby authorizes the President or any Vice President of the Company: (1) Appoint Attorney(s) in Fact and authorize the Attorney(s) in Fact to execute on behalf of the Company bonds and undertakings, contracts of indemnity and other writings obligatory in the nature thereof and to attach the seal of the Company thereto; and (2) to remove, at any time, any such Attorney-in-Fact and revoke the authority given. And, be it

FURTHER RESOLVED: That the signatures of such officers and the seal of the Company may be affixed to any such Power of Attorney or certificate relating thereto by facsimile, and any such Power of Attorney so executed and certified by facsimile signatures and facsimile seal shall be valid and binding upon the Company in the future with respect to any bond or undertaking to which it is attached.

IN TESTIMONY WHEREOF, PHILADELPHIA INDEMNITY INSURANCE COMPANY HAS CAUSED THIS INSTRUMENT TO BE SIGNED AND ITS CORPORATE SEAL TO BE AFFIXED BY ITS AUTHORIZED OFFICE THIS 5TH DAY OF MARCH, 2021.



(Seal)

John Glomb, President & CEO
Philadelphia Indemnity Insurance Company

On this 5th day of March, 2021 before me came the individual who executed the preceding instrument, to me personally known, and being by me duly sworn said that he is the therein described and authorized officer of the PHILADELPHIA INDEMNITY INSURANCE COMPANY; that the seal affixed to said instrument is the Corporate seal of said Company; that the said Corporate Seal and his signature were duly affixed.

Notary Public:

Vanessa McKenzie

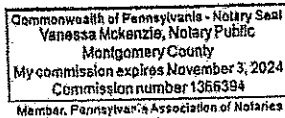

residing at:

Bala Cynwyd, PA

My commission expires:

November 3, 2024

I, Edward Sayago, Corporate Secretary of PHILADELPHIA INDEMNITY INSURANCE COMPANY, do hereby certify that the foregoing resolution of the Board of Directors and the Power of Attorney issued pursuant thereto on the 5th day March, 2021 are true and correct and are still in full force and effect. I do further certify that John Glomb, who executed the Power of Attorney as President, was on the date of execution of the attached Power of Attorney the duly elected President of PHILADELPHIA INDEMNITY INSURANCE COMPANY.

In Testimony Whereof I have subscribed my name and affixed the facsimile seal of each Company this

25th day of February 2022



Edward Sayago
Edward Sayago, Corporate Secretary
PHILADELPHIA INDEMNITY INSURANCE COMPANY

**HUDSON- Alternate A
HUDSON, NEW HAMPSHIRE**

BID FORM

Notes:

1. All prices must be written in ink. Unit prices must be written in words as well as figures for the entire proposal. In case of discrepancy, the amount in words shall govern.
2. All prices given shall include items delineated in the Measurement and Payment Section, and in accordance with the Drawings, Specifications and Contract Documents.

Item No.	Description	Quantity	Unit	Unit Price	Total Price
203.1	Common Excavation Fifteen dollars and Zero cents.	4,000	CY	\$15.00	\$60,000.00
209.1	Granular Backfill Twenty-Five dollars and Zero cents.	670	CY	\$25.00	\$16,750.00
214	Fine Grading Fifteen Hundred dollars and Zero cents.	1	U	\$1,500.00	\$1,500.00
304.2	Gravel (F) Eighteen dollars and Fifty cents.	3,150	CY	\$18.50	\$58,275.00
304.3	Crushed Gravel (F) Twenty-Five dollars and Zero cents.	900	CY	\$25.00	\$22,500.00
403.11	Hot Bituminous Paving, Machine Method Two Hundred dollars and Zero cents.	160	TON	\$200.00	\$32,000.00
508	Structural Fill Twenty-Five dollars and Zero cents.	220	CY	\$25.00	\$5,500.00
520.01	Concrete Class AA Five Hundred Fifty dollars and Zero cents.	500	CY	\$550.00	\$275,000.00
544	Reinforcing Steel (F) One dollar and Sixty cents.	54,000	LB	\$1.60	\$86,400.00
550.1	Structural Steel (F) Three dollars and Twenty cents.	58,300	LB	\$3.20	\$186,560.00

585.3	Stone Fill, Class C Fifty _____ dollars and Zero _____ cents.	70	CY	\$50.00	\$3,500.00
593.411	Geotextile, Perm Control CL 1, Non- Woven Six _____ dollars and Zero _____ cents.	400	SY	\$6.00	\$2,400.00
603.80212	12" Plastic Pipe (Smooth Interior) One Hundred _____ dollars and Zero _____ cents.	61	LF	\$100.00	\$6,100.00
604.124	Catch Basin Type B, 4' Dia Seventy-Five Hundred _____ dollars and Zero _____ cents.	1	U	\$7,500.00	\$7,500.00
606.6311	Safety Rail, w/Guard, Steel Ninety _____ dollars and Zero _____ cents.	410	LF	\$90.00	\$36,900.00
641	Loam Thirty _____ dollars and Zero _____ cents.	260	CY	\$30.00	\$7,800.00
645.531	Silt Fence Two _____ dollars and Zero _____ cents.	1,000	LF	\$2.00	\$2,000.00
646.31	Turf Establishment with Mulch and Tackifiers Zero _____ dollars and Twenty-Five _____ cents.	15,000	SF	\$.25	\$3,750.00
692	Mobilization Eighty-Five Thousand _____ dollars and Zero _____ cents.	1	U	\$85,000.00	\$85,000.00
TOTAL BID:					
Eight Hundred Ninety-Nine Thousand Four Hundred Thirty-Five _____ dollars \$899,435.00 and Zero _____ cents.					

Note:

- Items subsidiary to "Concrete" include, but are not limited to, joint materials, weep holes, sealers, etc.
- Items subsidiary to "Structural Steel" include, but are not limited to, roofing, flashing, purlins, anchor bolts, etc.

**HUDSON- Alternate B
HUDSON, NEW HAMPSHIRE**

BID FORM

Notes:

1. All prices must be written in ink. Unit prices must be written in words as well as figures for the entire proposal. In case of discrepancy, the amount in words shall govern.
2. All prices given shall include items delineated in the Measurement and Payment Section, and in accordance with the Drawings, Specifications and Contract Documents.

Item No.	Description	Quantity	Unit	Unit Price	Total Price
203.1	Common Excavation Eighteen dollars and Forty cents.	1,900	CY	\$18.40	\$34,960.00
508	Structural Fill Forty dollars and Zero cents.	220	CY	\$40.00	\$8,800.00
520.01	Concrete Class AA Five Hundred Fifty dollars and Zero cents.	500	CY	\$550.00	\$275,000.00
544	Reinforcing Steel (F) One dollars and Sixty cents.	54,000	LB	\$1.60	\$86,400.00
550.1	Structural Steel (F) Three dollars and Twenty cents.	58,300	LB	\$3.20	\$186,560.00
606.6311	Safety Rail, w/Guard, Steel Ninety dollars and Zero cents.	410	LF	\$90.00	\$36,900.00
692	Mobilization Seventy-One Thousand Two Hundred dollars and Zero cents.	1	U	\$71,200	\$71,200
TOTAL BID: Six Hundred Ninety-Nine Thousand Eight Hundred Twenty dollars and Zero cents.					\$699,820.00

Note:

- Items subsidiary to "Concrete" include, but are not limited to, joint materials, weep holes, sealers, etc.
- Items subsidiary to "Structural Steel" include, but are not limited to, roofing, flashing, purlins, anchor bolts, etc.

**CONSTRUCTION SERVICES FOR
WEST ROAD LANDFILL IMPROVEMENTS
TOWN OF HUDSON, NEW HAMPSHIRE**

In the interest of fairness and sound business practice, it is mandatory that you state any exceptions taken by you to our specifications.

It should not be the responsibility of the Town of Hudson to ferret out information concerning the materials, which you intend to furnish.

If your bid/quotation does not meet all of our specifications, you **must** so state in the space provided below:

Our bid meets all the specifications outlined in the bidding documents.

Proposals on equipment, vehicles, supplies, service and materials not meeting specifications may be considered by the Town, however, all deviations must be listed above.

If your proposal does not meet our specifications, and your exceptions are not listed above, the Town of Hudson may claim forfeiture on your proposal bond, if submitted.

Signed: W. D. MANAGER
I DO meet specifications

Signed: _____
I DO NOT meet specifications as listed in this bid; exceptions are in the space provided.

Failure to submit this form with your RFP response may result in your Proposal being rejected as unresponsive.



THE STATE OF NEW HAMPSHIRE
DEPARTMENT OF TRANSPORTATION



VICTORIA F. SHEEHAN
COMMISSIONER

WILLIAM CASS, P.E.
ASSISTANT COMMISSIONER

December 13, 2021

William P. Davis Excavation, LLC
19 Lafayette Road
Hampton, NH 03842

Your request for prequalification in order that you may bid on projects advertised and let by this Department has been reviewed and is in compliance with the prequalification regulations for Public Works and/or Road and Bridge projects valued at **\$1,000,000 or under**. The Department assigns ratings in the various classifications, some of which are listed below:

- | | |
|-----------------------|---------------------|
| Road Construction | Bridge Construction |
| Site | Utilities |
| Water | Sewer |
| Traffic Signals | Highway Lighting |
| Building Construction | Bridge Painting |
| Mechanical | Electrical |
| Asbestos Removal | Paving |
| Roofing | Landscaping |

Eligibility for bidding on a particular project will be determined by the Prequalification Committee at the time that the request for plans, specifications and a proposal is made. Their decision will be based on the magnitude and complexity of the project in question and on the requesting firm's capability to successfully prosecute to completion the particular project.

Your firm has been rated on a project by project basis for those projects in the following classifications: **Box culvert, water, sewer and site work**. Your prequalification will expire on **March 31, 2023**.

All prequalification information supplied to this office will be held in strict confidence and used for no other purpose than for prequalification for bidding on projects advertised and let by this Department.

Sincerely,

Michelle Drouin

Michelle Drouin
Prequalification Administrator

PHILADELPHIA INDEMNITY INSURANCE COMPANY

One Bala Plaza, Suite 100
Bala Cynwyd, PA 19004-0950

Power of Attorney

KNOW ALL PERSONS BY THESE PRESENTS: That PHILADELPHIA INDEMNITY INSURANCE COMPANY (the Company), a corporation organized and existing under the laws of the Commonwealth of Pennsylvania, does hereby constitute and appoint Mark D. Leskaniemi; Bette A. Botticello OF THE TOWN OF NEEDHAM, STATE OF MASSACHUSETTS, its true and lawful Attorney-in-fact with full authority to execute on its behalf bonds, undertakings, recognizances and other contracts of indemnity and writings obligatory in the nature thereof, issued in the course of its business and to bind the Company thereby, in an amount not to exceed \$50,000,000.

This Power of Attorney is granted and is signed and sealed by facsimile under and by the authority of the following Resolution adopted by the Board of Directors of PHILADELPHIA INDEMNITY INSURANCE COMPANY on the 14th of November, 2016.

RESOLVED: That the Board of Directors hereby authorizes the President or any Vice President of the Company: (1) Appoint Attorney(s) in Fact and authorize the Attorney(s) in Fact to execute on behalf of the Company bonds and undertakings, contracts of indemnity and other writings obligatory in the nature thereof and to attach the seal of the Company thereto; and (2) to remove, at any time, any such Attorney-in-Fact and revoke the authority given. And, be it

FURTHER RESOLVED: That the signatures of such officers and the seal of the Company may be affixed to any such Power of Attorney or certificate relating thereto by facsimile, and any such Power of Attorney so executed and certified by facsimile signatures and facsimile seal shall be valid and binding upon the Company in the future with respect to any bond or undertaking to which it is attached.

IN TESTIMONY WHEREOF, PHILADELPHIA INDEMNITY INSURANCE COMPANY HAS CAUSED THIS INSTRUMENT TO BE SIGNED AND ITS CORPORATE SEAL TO BE AFFIXED BY ITS AUTHORIZED OFFICE THIS 5TH DAY OF MARCH, 2021.



(Seal)

John Glomb, President & CEO
Philadelphia Indemnity Insurance Company

On this 5th day of March, 2021 before me came the individual who executed the preceding instrument, to me personally known, and being by me duly sworn said that he is the therein described and authorized officer of the PHILADELPHIA INDEMNITY INSURANCE COMPANY; that the seal affixed to said instrument is the Corporate seal of said Company; that the said Corporate Seal and his signature were duly affixed.

Notary Public:

Vanessa McKenzie

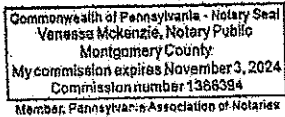

residing at:

Bala Cynwyd, PA

My commission expires:

November 3, 2024

I, Edward Sayago, Corporate Secretary of PHILADELPHIA INDEMNITY INSURANCE COMPANY, do hereby certify that the foregoing resolution of the Board of Directors and the Power of Attorney issued pursuant thereto on the 5th day March, 2021 are true and correct and are still in full force and effect. I do further certify that John Glomb, who executed the Power of Attorney as President, was on the date of execution of the attached Power of Attorney the duly elected President of PHILADELPHIA INDEMNITY INSURANCE COMPANY.

In Testimony Whereof I have subscribed my name and affixed the facsimile seal of each Company this 14th day of December, 2021



Edward Sayago, Corporate Secretary
PHILADELPHIA INDEMNITY INSURANCE COMPANY

Rochester Reservoir Spillway Modification Project: Contract - \$87,294.34

Reconstruction of reservoir overflow spillway.

Owner: City of Rochester, NH

Prime Contractor: WP Davis Excavation LLC

Dennison Road Sewer Replacement Project: Contract - \$60,000.00

Replacement of 300LF 8" Sewer main with service and ancillary Work.

Owner: Town of Durham, NH (Owner Reference Contact Information Below)

Prime Contractor: WP Davis Excavation LLC

Temple Court & Reed Street Sewer Project: Contract - \$ 112,000.00

Installation of sewer main, services, and manhole structures, and roadway reconstruction.

Owner: Town of Goffstown, NH

Prime Contractor: WP Davis Excavation LLC

Skyhaven Airport Sewer Project: Contract - \$60,000.00

Installation of 1500LF 2" force main, 500LF 4" gravity main, and a central lift station.

Owner: Pease Development Authority (Owner Reference Contact Information Below)

Prime Contractor: WP Davis Excavation LLC

Nashua Hydrant & Valve Replacement Project: Contract - \$179,925.00

Replacement of 21 hydrants and valves and the Nashua WWTP

Owner: City of Nashua NH (Owner/Engineer Reference Contact Information Below)

Prime Contractor: WP Davis Excavation LLC

Waterline Connection Project, Former Pease AFB: Contract - \$97,379.90

Install 900LF of water service line via direction drilling.

Owner: USAF

Prime Contractor: Woods Environment

Alternate Form
W-9 (rev 01/2011)

Request for Taxpayer Identification Number and Certification

Give form to the requester. Do not send to the IRS.

Name (as shown on your income tax return)

William P Davis Excavation LLC

Business name/disregard entity name, if different from above

Check appropriate box for federal tax classification (required): Individual/ Sole proprietor C Corporation S Corporation
 Partnership Trust/estate
 Limited Liability Company - Enter the tax classification (C= Corporation, S-S Corporation, P= Partnership) _____
 Other (see instructions)

Exempt payee

Address (number, street, and apt. or suite no.)

PO Box 758

City, state, and ZIP code

Hampton, NH 03843

Requester's name and address (optional)

List account number(s) here (optional)

Part I Taxpayer Identification Number (TIN)

Enter your TIN in the appropriate box. The TIN provided must match the name given on the "Name" line to avoid backup withholding. For individuals, this is your social security number (SSN). However, for a resident alien, sole proprietor, or disregarded entity, see the Part I instructions on page 3. For other entities, it is your employer identification number (EIN). If you do not have a number, see *How to get a TIN* on page 3. **Note.** If the account is in more than one name, see the chart on page 4 for guidelines on whose number to enter.

Social Security number -

Employer identification number -

30-0485207

Part II Certification

Under penalties of perjury, I certify that:

1. The number shown on this form is my correct taxpayer identification number (or I am waiting for a number to be issued to me), and
2. I am not subject to backup withholding because: (a) I am exempt from backup withholding, or (b) I have not been notified by the Internal Revenue Service (IRS) that I am subject to backup withholding as a result of a failure to report all interest or dividends, or (c) the IRS has notified me that I am no longer subject to backup withholding, and
3. I am a U.S. citizen or other U.S. person (defined below).

Certification instructions: You must cross out item 2 above if you have been notified by the IRS that you are currently subject to backup withholding because you have failed to report all interest and dividends on your tax return. For real estate transactions, item 2 does not apply. For mortgage interest paid, acquisition or abandonment of secured property, cancellation of debt, contributions to an individual retirement arrangement (IRA), and generally, payments other than interest and dividends, you are not required to sign the certification, but you must provide your correct TIN. See the instructions on page 4.

Sign Here	Signature of U.S. Person 	Date: 2/24/22
-----------	--	---------------

General Instructions

Section references are to the Internal Revenue Code unless otherwise noted.

Purpose of Form

A person who is required to file an information return with the IRS must obtain your correct taxpayer identification number (TIN) to report, for example, income paid to you, real estate transactions, mortgage interest you paid, acquisition or abandonment of secured property, cancellation of debt, or contributions you made to an IRA. Use Form W-9 only if you are a U.S. person (including a resident alien), to provide your correct TIN to the person requesting it (the requester) and, when applicable, to: 1. Certify that the TIN you are giving is correct (or you are waiting for a number to be issued), 2. Certify that you are not subject to backup withholding, or 3. Claim exemption from backup withholding if you are a U.S. exempt payee. If applicable, you are also certifying that as a U.S. person, your allocable share of any partnership income from a U.S. trade or business is not subject to the withholding tax on foreign partners' share of effectively connected income. **Note.** If a requester give you a form other than Form W-9 to request your TIN, you must use the requester's form if it is substantially similar to this Form W-9. Pursuant to IRS Regulations, you must furnish your Taxpayer IRS Identification Number (TIN) to the City whether or not you are required to file tax returns. If this number is not provided, you may be subject to required withholding on each payment made to you. To avoid this withholding & to ensure that accurate tax information is reported to the IRS, **A RESPONSE IS REQUIRED.**

AMENDMENT # 1 – QUESTIONS AND ANSWERS RELATED TO THIS PROJECT

**WEST ROAD LANDFILL IMPROVEMENTS
TOWN OF HUDSON, NEW HAMPSHIRE**

In the interest of fairness and sound business practice, the Town will provide answers for questions we have received for this project. Deadline for all questions is February 10, 2022. It shall be the responsibility of the Contractor to be aware of this amendment and providing this document with the bid documents.

Question 1: Are we required to submit two (2) bids form, Alternate A & B?

Answer 1: You are required to submit a bid form for alternate A. We encourage you to submit Alternative B, if your alternative A bit is over the budget.

Question 2: Are we required to submit to separate bid bonds ?

Answer 2: You will only be required to submit one bond that will represent the highest bid amount.

Question 3: Does the Town still require handrail installation after the pre bid meeting?

Answer 3: No, we will replace the handrail item with 6” bollards & chain. We have attached the specs for the pipe bollard and cover which can be Idealshield or Postguard.

Question 4: What will be the layout and spacing for the bollards ?

Answer 4: The bollard will be located on the inside and outside corners and twelve (12) feet apart. See attachment for additional detail

Question 5: Does the Town still require chain installation and what is the required spacing ?

Answer 5: Chain will be required at the four (4) and two (2) foot height.

Question 6: How will we get paid for the bollards and chain items?

Answer 5: Contractor shall be paid under the handrail item for the bollard and chain installation.

Question 7: Who will be responsible for the concrete testing?

Answer 7: The contractor shall be responsible for the concrete testing.

Question 8: Who will be responsible for the steel inspection?

Answer 8: The Town will be responsible for the steel inspection.

Question 9: Who is responsible for any permits and fees?

Answer 9: The contractor shall be responsible for pulling foundation permit and all permit fees will be waived.

Question 10: Will an as built be required?

Answer 10: Yes, an asbuilt , including layout and grading, stamped by a NH Professional Land Surveyor will be required to confirm that the project was built to design.

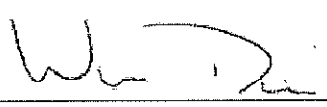
Signed:  _____

I DO understand the above and agree to meet specifications

Signed: _____

I DO NOT meet specifications as listed in this amendment

Failure to submit this amendment form with your RFP response may result in your Proposal being rejected as unresponsive.

Company: William P Davis Excavation LLC

Signed by:  MANAGER

Printed or typed name: William Davi, Manager

Address: 19 Lafayette Road, PO Box 758, Hampton, NH 03842

Telephone number: 603-944-5844 fax number: _____

Toll free number: _____ e-mail: _____

Cell phone number: _____

Primary point of contact: Will Davis

Payment terms and conditions: Per The Contract

Please fill out, sign and return to:

Town of Hudson
Town Engineer
Mr. Elvis Dhima, P.E.,
12 School Street, Hudson, NH 03051
603-886-6008; 603-594-1142 (Fax)
edhima@hudsonnh.gov

Due Date/Time: February 25, 2022, Not Later Than 10:00 AM

1-800-639-2199

Fax (603) 224-2927

Bollards\6in_Bollard_w_Base

Phoenix Precast Products

Phoenix Precast Products

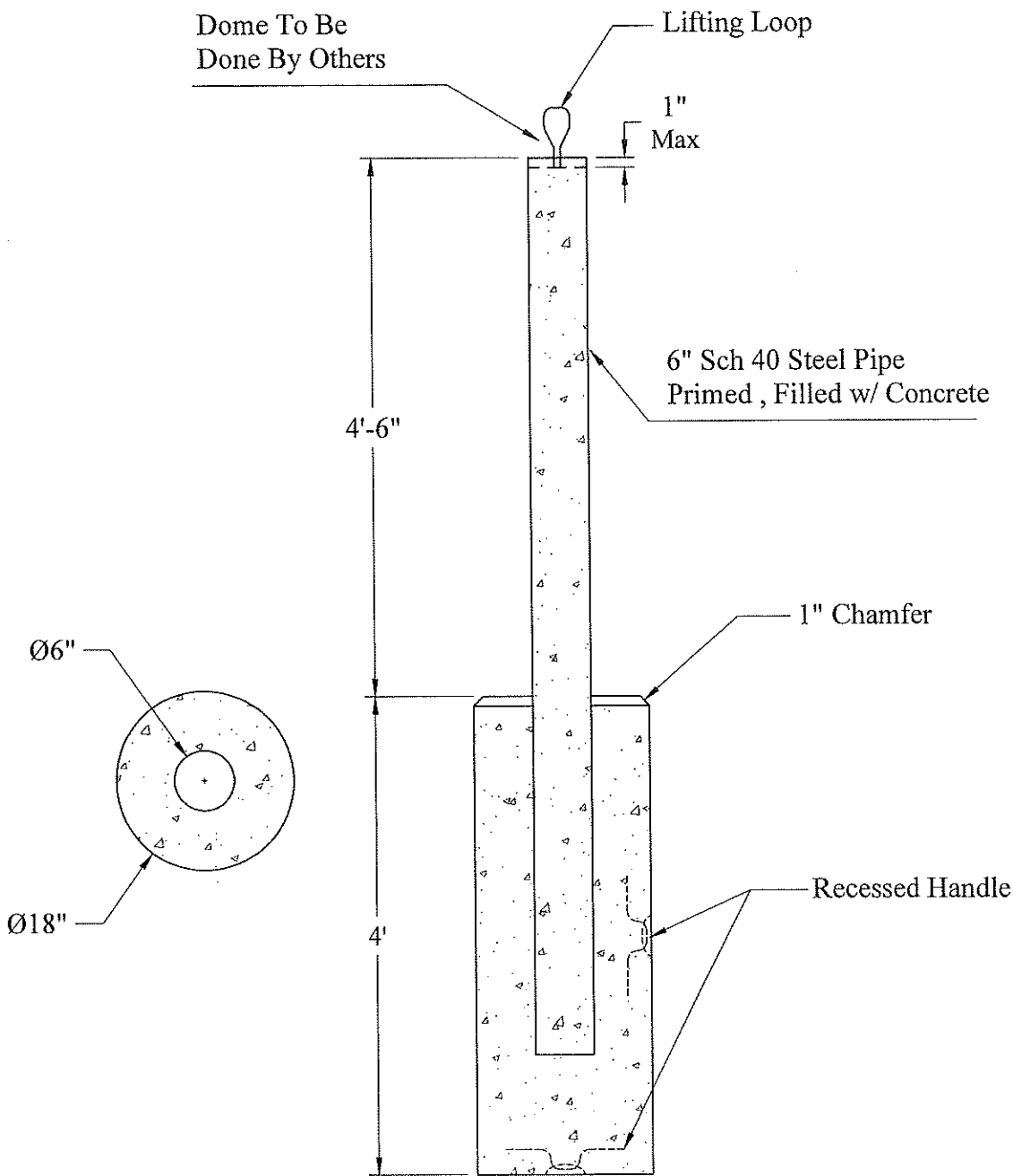

Decorative Polyethylene Sleeves Available

General Notes

- 1.) Concrete: $f_c = 4,000$ PSI @ 28 Days Minimum
- 2.) Weight: 1,300 Lbs

Phoenix
Precast
Products

6" Dia. Bollard
With Base

P/N: PB-6 Bollard



Improve the Safety & Look of Your Facility "Shield It" with the Original Bumper Post Sleeve

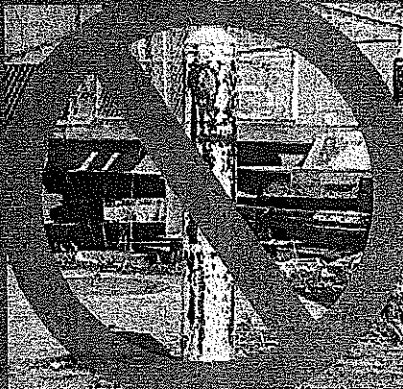

Clean It Up



**Highly Visible in
OSHA Yellow**

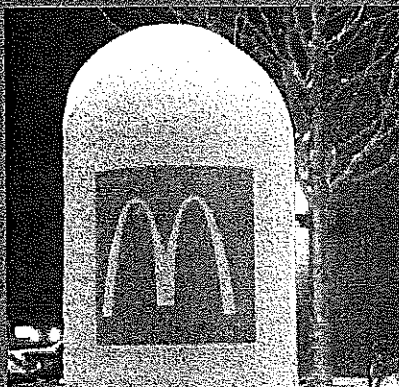

Custom Logos

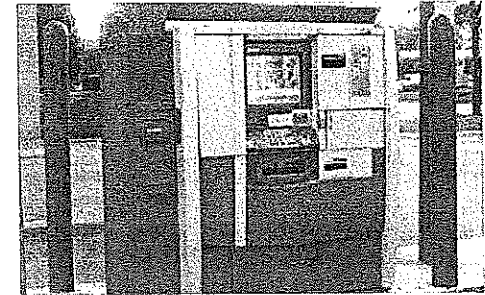
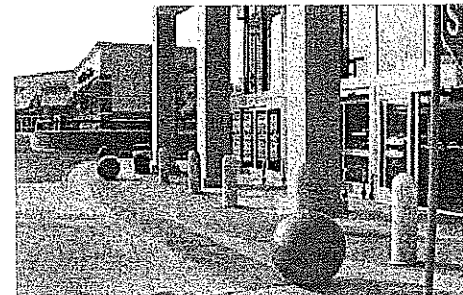
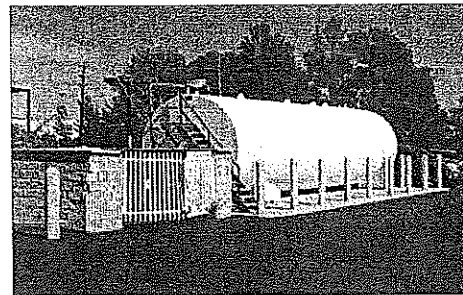
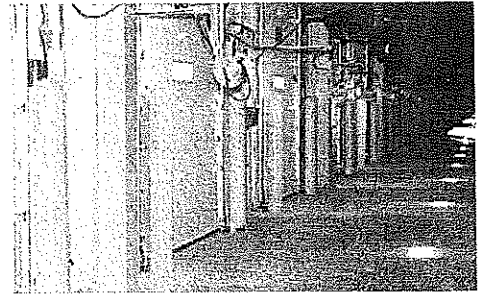
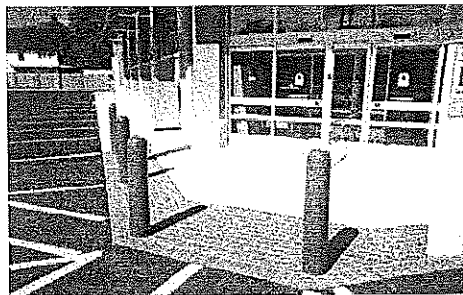

Bumper Post Sleeve Features & Benefits:

FEATURES

- Available in 1/8" & 1/4" wall thickness
- UV & Anti-Static Additives
- Cut to Custom Heights
- Covers Posts from 3" to 11"
- Polyethylene Thermoplastic

BENEFITS

- Permanent Installation Reduces Theft
- Chemical & Water Resistant
- Custom Logos and Colors
- Improves Safety and Visibility

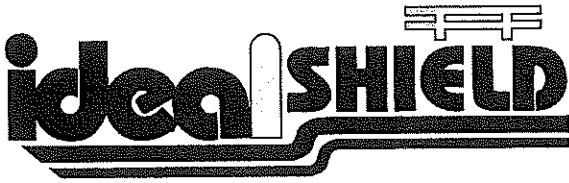

Ideal Shield®
Bumper Post Sleeve
Three Step Installation

Frequently Asked Questions

How do I clean the Ideal Sleeve®?

The Ideal Sleeve® is easily cleaned with environmentally friendly industrial strength detergent and water solutions. Avoid using abrasive cleaners.

How does the Ideal Sleeve® hold up in the elements?

The Ideal Sleeve® withstands temperatures from 210°F to -40°F (99°C to -40°C). Cold storage and food processing plants like the Ideal Sleeve® because of its resistance to subzero temperatures. The Ideal Sleeve® is used in all climates across North America.

How do I secure the Ideal Sleeve® to an existing bollard?

Simply apply a strip of neoprene adhesive tape 3" from the top edge of the post, leaving a 1" gap between the ends of the tape. At the bottom of the post wrap the neoprene adhesive tape completely around so that the ends of the tape meet this time. Slowly slide the sleeve over the post with a twisting motion. You will hear air being forced out of the sleeve. The sleeve will fit securely around the post.

Can you match my company's colors?

OSHA yellow, red, blue, and black are the standard sleeve colors, however we can match almost any pantone or color sample to meet your company's needs. Custom logos are also available upon request.

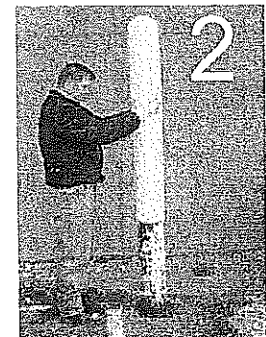

E-MAIL: info@idealshield.com

WEBSITE: www.idealshield.com

Bumper Post Sleeve Specs

Pipe Size, Inches	Product Number	Height, Inches
3"	BPD-YL-3-60-S	60"
3 1/2"	BPD-YL-3.5-52-S	52"
3 1/2"	BPD-YL-3.5-68-S	68"
4"	BPD-YL-4-36-S	36"
4"	BPD-YL-4-52-S	52"
4"	BPD-YL-4-60-S	60"
5"	BPD-YL-5-52-S	52"
5"	BPD-YL-5-72-S	72"
6"	BPD-YL-6-52-S	52"
6"	BPD-YL-6-60-S	60"
6"	BPD-YL-6-65-S	65"
6"	BPD-YL-6-84-S	84"
7"	BPD-YL-7-56-S	56"
8"	BPD-YL-8-52-S	52"
8"	BPD-YL-8-60-S	60"
8"	BPD-YL-8-69-S	69"
10"	BPD-YL-10-69-S	69"

Fits Pipe 3 to 11 Inches

How to figure which sleeve size to order:

1. Measure the circumference, (distance around the post) you wish to cover.
2. Take that dimension and divide by pi (3.14) to receive the pipe size.

Example: circumference is 21.5"
 divide by 3.14
 pipe size is 6 7/8"
3. The bumper post sleeve you need is a 6".

Other Ideal Shield® Products

- Guardrail Systems
- Handrail Systems
- Sign Systems
- Goal Post Systems
- Cart Guides
- Wall Systems
- Bike Racks
- Cart Corrals

IDEAL SHIELD, L.L.C.
2525 Clark St. Detroit, MI 48209
(313) 842-7290 Fax (313) 842-7860
Toll Free: 1-800-731-1722



6" Sleeve

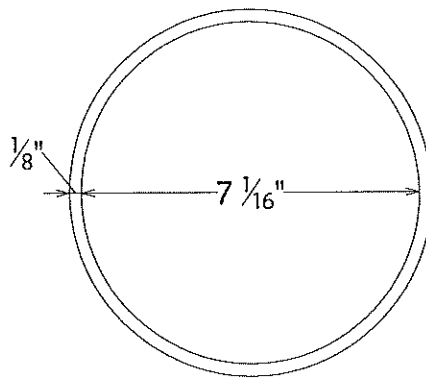

Cross Section of Sleeve

THIS DRAWING AND ALL THE INFORMATION THEREON IS THE PROPERTY OF IDEAL SHEEL. IT IS CONFIDENTIAL AND MUST NOT BE MADE PUBLIC, NOR COPIED, NOR USED TO THE DISADVANTAGE OF IDEAL SHEEL AND IS SUBJECT TO RETURN ON DEMAND.
 COPYRIGHT 2000 - IDEAL SHEEL

NO.	REVISIONS	DATE	APPROVED

IDEAL SHEEL
 2525 Clark St.
 Detroit, MI 48209

PROJECT	CUSTOMER	DESCRIPTION	DATE BY	APPROVED BY	DATE
		6" Sleeve	ACB		3/31/06



4" Sleeve

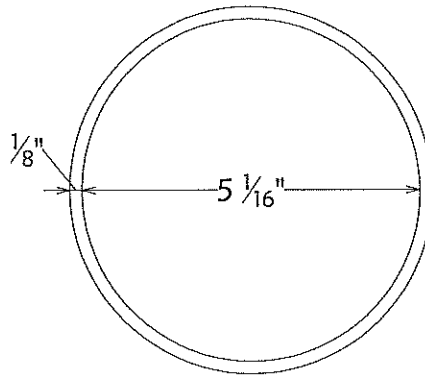

Cross Section of Sleeve

THIS DRAWING AND ALL THE INFORMATION THEREON IS THE PROPERTY OF THE IDEAL SHIELD. IS CONFIDENTIAL AND MUST NOT BE MADE PUBLIC, NOR COPIED, NOR USED, TO THE DETRIMENT OR DISADVANTAGE OF SAID IDEAL SHIELD AND IS SUBJECT TO RETURN ON DEMAND.
 COPYRIGHT 2009 - IDEAL SHIELD

NO.	REVISIONS	DATE	APPROVED

IDEAL SHIELD
 2020 Clark St.
 Detroit, MI 48209

PROJECT	CUSTOMER	DESCRIPTION	DATE IN	APPROVED BY	DATE
		4" Sleeve	ACB		3/31/06



1-866-825-8659

Bollard Cover Sizing Tool

Place paper horizontally over pipe from **OD to OD to get a correct measurement.

*Bollard cover sizes are Ideal Shield Specific
**OD = Outside Diameter

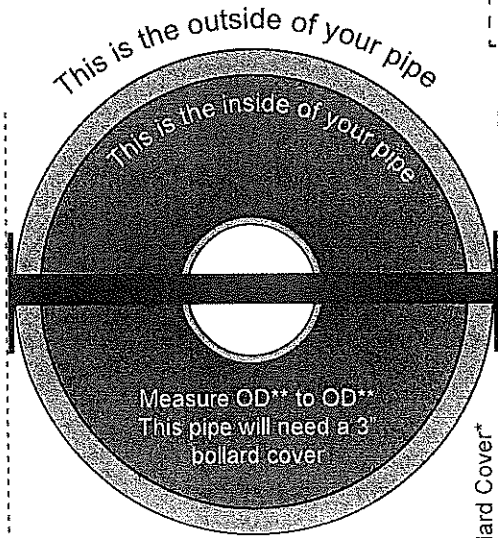

3.5" OD = 3" Bollard Cover*

4" OD = 3.5" Bollard Cover*

4.5" OD = 4" Bollard Cover*

5.563" OD = 5" Bollard Cover*

6.625" OD = 6" Bollard Cover*

7.5" OD = 7" Bollard Cover*

8.625" OD = 8" Bollard Cover*

Anything beyond 8" will need a 10" Bollard Cover*

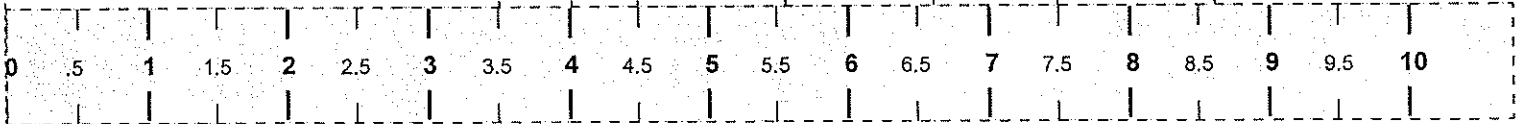

Maintenance-free Bollard Protection!



by Encore

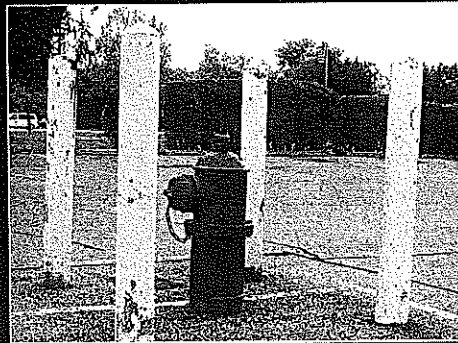

Bollards WITHOUT Post Guard

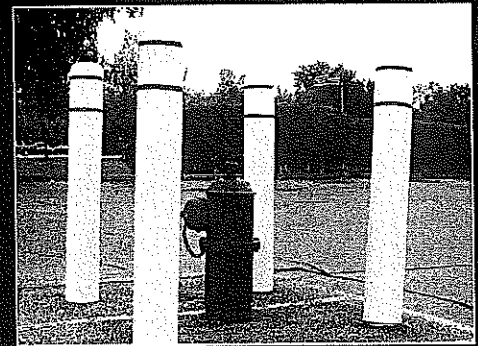

Bollards WITH Post Guard

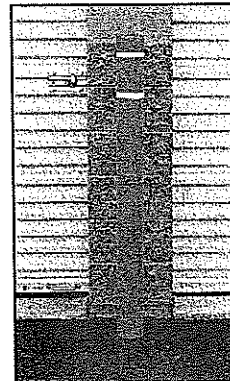
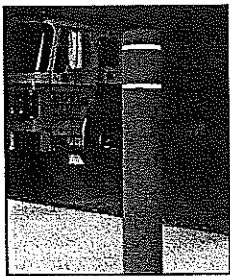

Great Looking Protection at Low Cost

Quick Payback
Save scraping and painting

Installs Easily
Slides over existing post

High Quality Plastic
Designed for all weather conditions

Colorful Choices
Covers and stripes

Fade Resistant
Ultraviolet stable for 5 years

Recessed Reflective Striping
Increase visibility and safety

Improves Property Appearance
At a very low price!

Wide Selection of Sizes
Many diameters and lengths

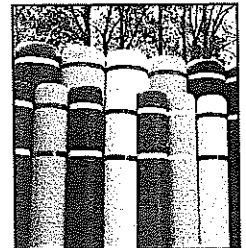
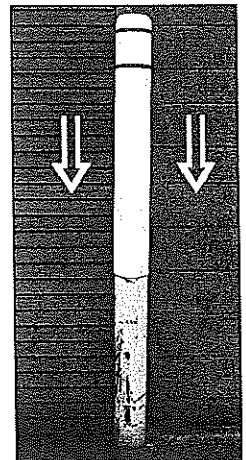

"We've cut maintenance costs and reduced customer complaints from dinged car doors."

John Nelson
Beaumont Hospitals



www.encorepostguard.com

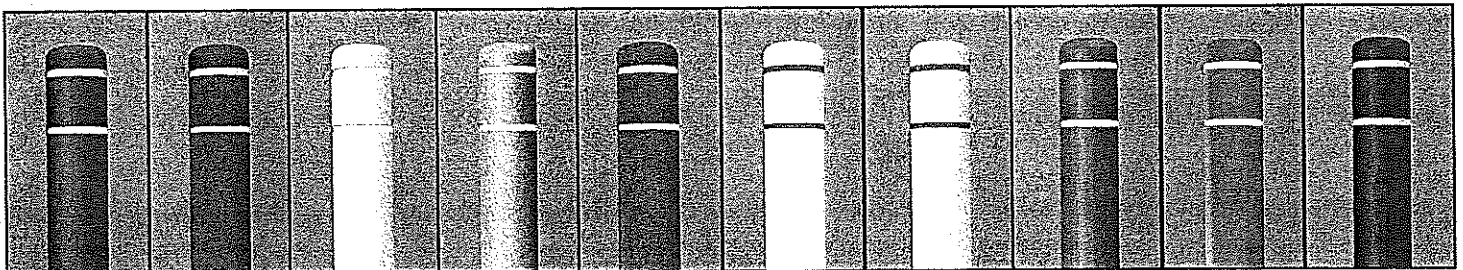

Maintenance-free Bollard Protection!



by *Encore*

Why Paint?

It's easy to install and Post Guard saves time and costs!



Every Post Guard is packaged with two foam strips.

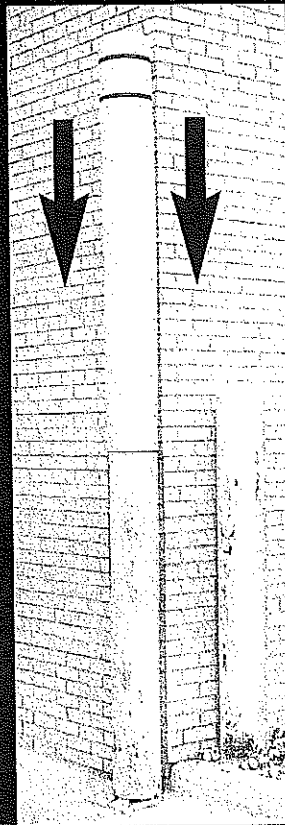

It easily slides over the post for a snug and secure fit.

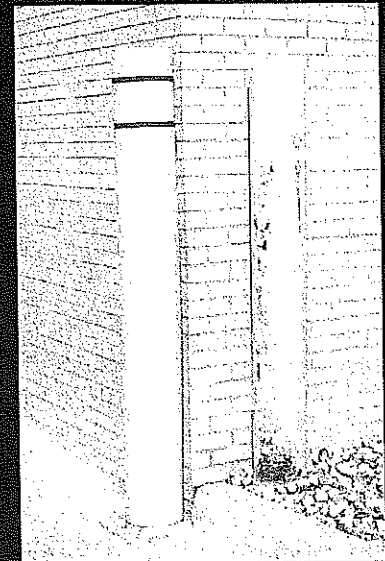

Post Guard looks good!

Post Guard is a protective sleeve that easily fits over posts. It saves time and costs by eliminating constant scraping and repainting. The plastic part contains ultraviolet and anti-static additives that withstand extreme temperatures. Custom colors, symbols and company logos are available.

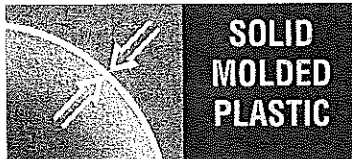

**SOLID
MOLDED
PLASTIC**

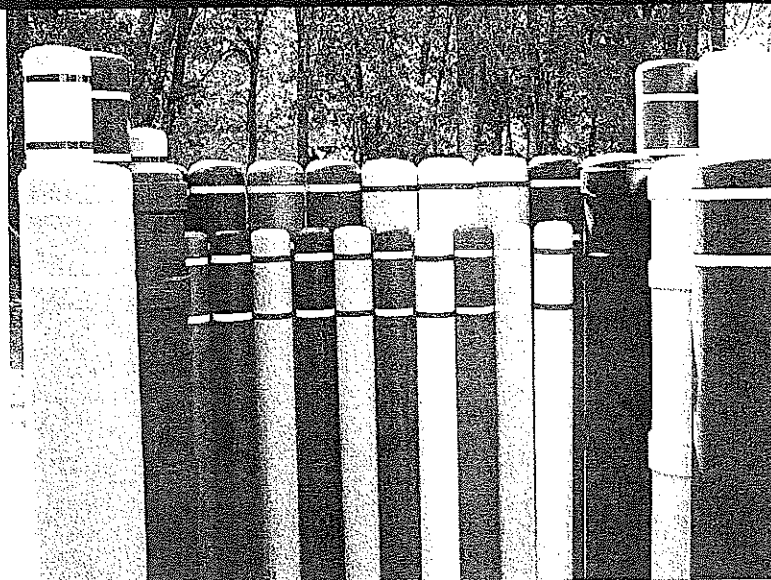

Post Guard sizes:

- 4.5" Dia. x 52"
- 4.5" Dia. x 64"
- 7" Dia. x 60"
- 7" Dia. x 72"
- 8-7/8" Dia. x 72"
- 10-7/8" Dia. x 60"

Square:
4.5" x 4.5" x 56"

Easily trimmed on-site to fit your application!

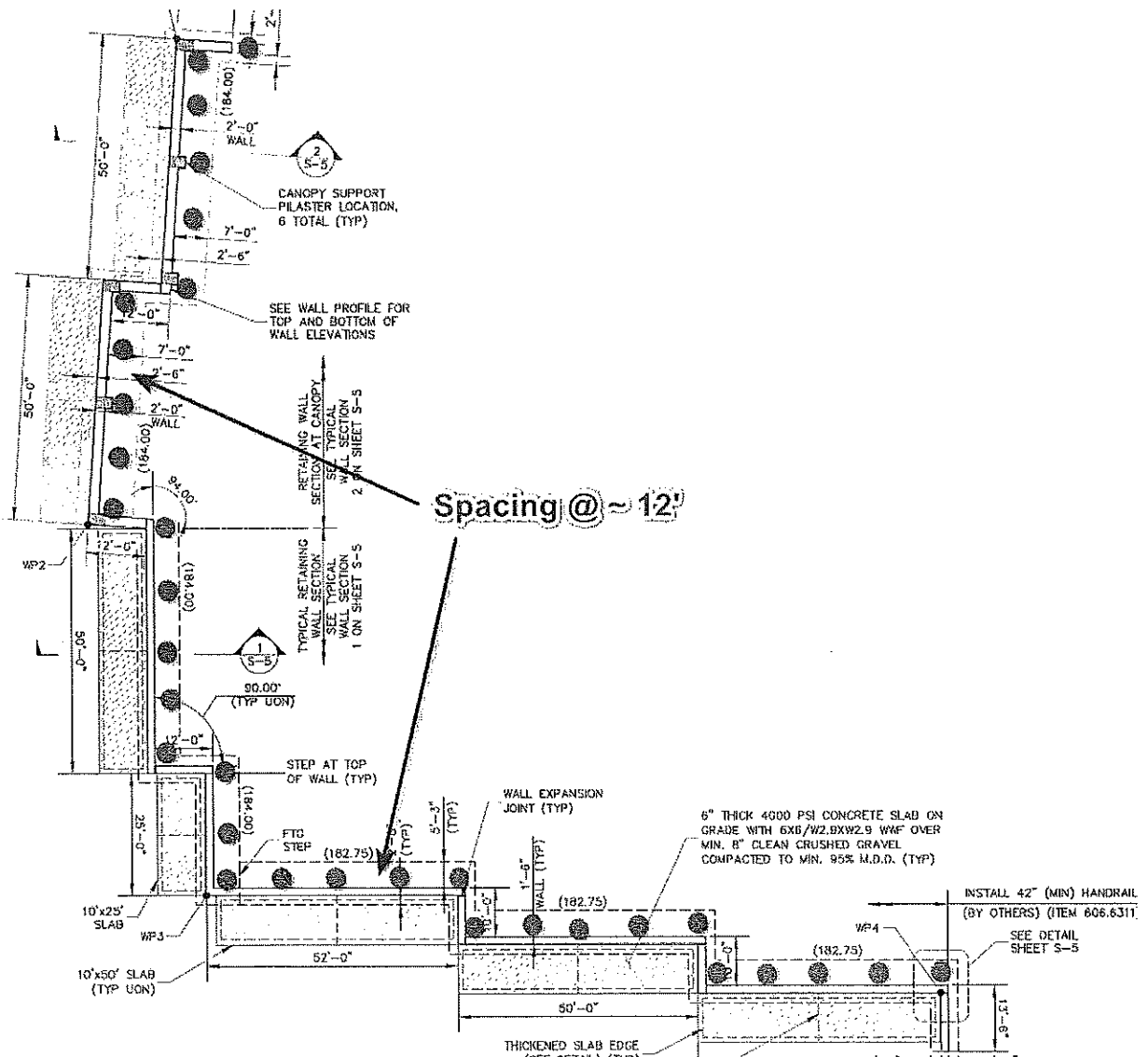

Spacing @ ~ 12'

1" Heavy Duty Chain - Yellow Coated

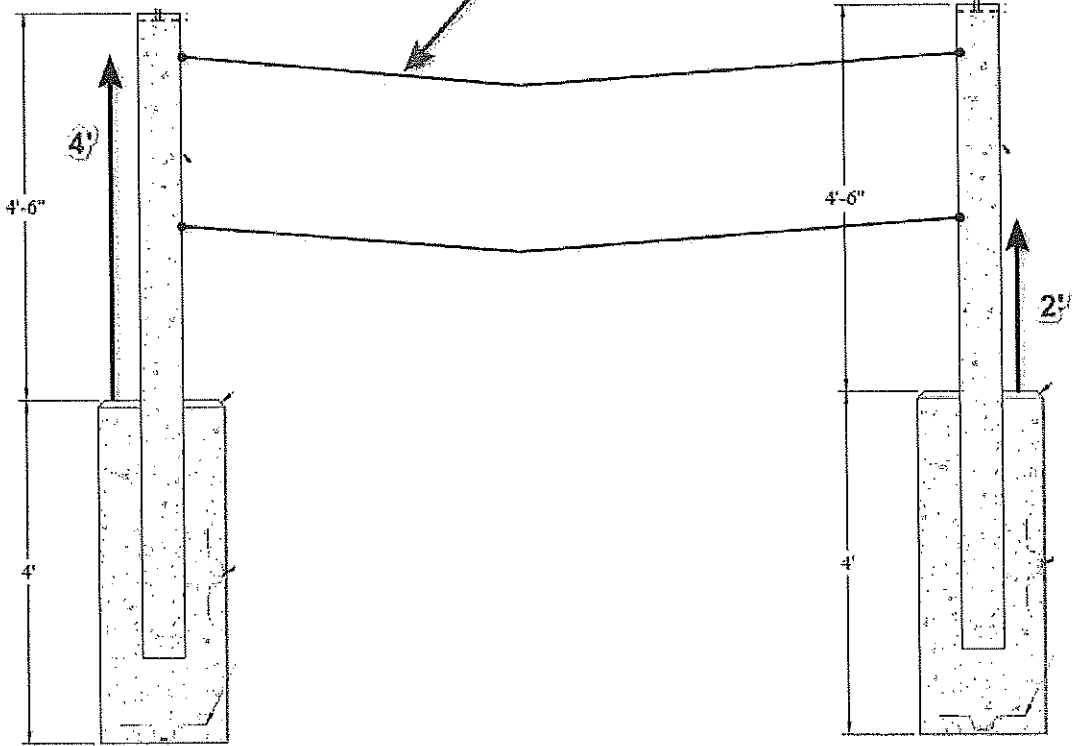

Agenda
3-27-22

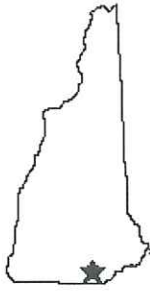

TOWN OF HUDSON

Engineering Department



8C

12 School Street • Hudson, New Hampshire 03051 • Tel: 603-886-6008 • Fax: 603-816-1291

TO: Steve Malizia, Town Administrator
Board of Selectmen

FROM: Elvis Dhima, P.E., Town Engineer

DATE: March 8, 2022

RE: Inspection Services Award for Transfer Station Upgrades

RECEIVED

MAR 08 2022

TOWN OF HUDSON
SELECTMEN'S OFFICE

The Town of Hudson hired CMA Engineers, Inc. for the transfer station master plan and design services for the current transfer station upgrades.

For the construction phase, we need support with shop drawing review, quality control and assurance during construction and providing feedback to the contractor for the steel and canopy construction phase.

Town Engineer's recommendation is to hire CMA Engineers, Inc. on an as-needed basis to provide support during the construction phase.

Motion:

To approve the contract for inspection services for the Transfer Station Updates to CMA Engineers, Inc., for the amount of, not to exceed, \$7,500, using American Rescue Plan Account #: 7203.



March 3, 2022

Mr. Elvis Dhima, P.E., Town Engineer
Town of Hudson
12 School Street
Hudson, NH 03051

**Re: Town of Hudson Transfer Station - Engineering Services
Amendment #2 to Engineering Services for Hudson Transfer Station Upgrades
CMA Eng. #1197**

Dear Elvis:

In response to your request, we have prepared this Amendment #2 to our contract for engineering services for the Town of Hudson Transfer Station Improvements. The amendment includes work to support the Town through the construction phase of the planned improvements to the retaining walls at the Town transfer station. The Amendment modifies our contract for Engineering Services for Transfer Station Upgrades dated September 14, 2020.

Background, Approach and Scope of Services

Work to date has included planning for long term improvements in a three-phase approach that includes retaining walls to support an elevated area for dropping off materials (Phase I), a scale (Phase II), and a new recycling facility and transfer station building (Phase III). Work also included final design of the retaining wall improvements (Phase I) and subsequent design revisions to those wall improvements to reduce the overall length of them.

The Town is now preparing to move forward with the construction of the Phase I work which includes the retaining wall system and associate site improvements for drainage.

Work will be performed as requested by the Town, and is assumed to include the following tasks:

- Attendance at meetings.
- Review of shop drawings and product submittals for conformance with project specifications and contract plans.
- Periodic site visits for review of materials, conformance with the design, and construction progress at critical times within the construction.
- Responses to RFIs and questions regarding design intent.

It is assumed that the Town or the selected contractor shall be responsible for the cost of material testing including concrete testing during the construction of Phase I.

Schedule

CMA Engineers understands that the work related to the construction of the transfer station retaining walls is currently being advertised for bids. We are prepared to be available for the construction engineering services included in this proposal upon commencement of that construction.

Engineering Fees

The Town has requested a **\$7,500** budget for the work covered under this contract. CMA Engineers will not exceed **\$7,500** in engineering fees without reviewing with the Town the circumstances for such increase(s) and reaching consensus on a mutually agreeable adjustment. Based on standard CMA Engineers rates, this budget is expected to provide 40-60 hours of work, inclusive of expenses.

Engineering fees will be assessed on the basis of CMA Engineers, Inc. standard rates. Engineering staff are invoiced at the rate of salary cost (wage rate plus 35% to cover statutory and customary fringe benefits) times a factor of 2.45. Principal time is invoiced at the lesser rates of \$195 for Craig Musselman, P.E. and William A. Straub, P.E. The fixed rate for Principal time is subject to annual inflationary adjustments. Sub-consultants will be invoiced at cost times 1.15. Expenses are invoiced at cost. Mileage will be billed at the prevailing IRS rate. CADD computer time is invoiced at \$10/hr.

Contract Terms

Work will be performed in accordance with our contract for engineering services referenced above and dated September 14, 2020. The terms and conditions of that contract shall apply except where modified above.

If you have any questions, please don't hesitate to call. If you concur with the arrangements outlined herein, you may authorize us to proceed by signing in the space(s) indicated below.

Very truly yours,
CMA ENGINEERS, INC.



Paul D. Schmidt, P.E.
President

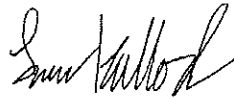

Liam B. Kalloch, P.E.
Project Engineer

Accepted and Authorized to Proceed:

Town of Hudson, NH

Date

LBK:rol

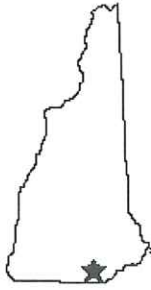

TOWN OF HUDSON
Engineering Department



Agenda
3-22-22

8D

12 School Street • Hudson, New Hampshire 03051 • Tel: 603-886-6008 • Fax: 603-816-1291

TO: Steve Malizia, Town Administrator
Board of Selectmen

FROM: Elvis Dhima, P.E., Town Engineer
Jess Forrence, Public Works Director

DATE: March 17, 2022

RE: Bush Hill Road Improvement Opportunity

RECEIVED
MAR 17 2022
TOWN OF HUDSON
SELECTMEN'S OFFICE

Bush Hill Road is currently a road that has poor sight distance issues due to its geometry and layout. One of the most challenging spots is along 112- 118 Bush Hill Road segment.

The current owner of 116 and 117 Bush Hill Road, Mr. Tyler, has reached out to Town staff regarding a possibility of working with the Town to provide the necessary Right of Way to address these concerns. The Town of Hudson owns the property located at 112 Bush Hill Road, approximately 0.282 Acres of undeveloped land, adjacent to 116 Bush Hill Road.

The intent is to work with the owner to secure necessary Right of Way for future road improvement that will allow the Town to eliminate the sharp turns and improve public safety

The Town Engineer and Public Works Director's recommendation to the BOS is pursue this opportunity

Motion:

To authorize the Town Engineer to work with Public Works Director and Mr. Tyler, for a scope of work and fee related to the potential purchase/trade of Right of Way.

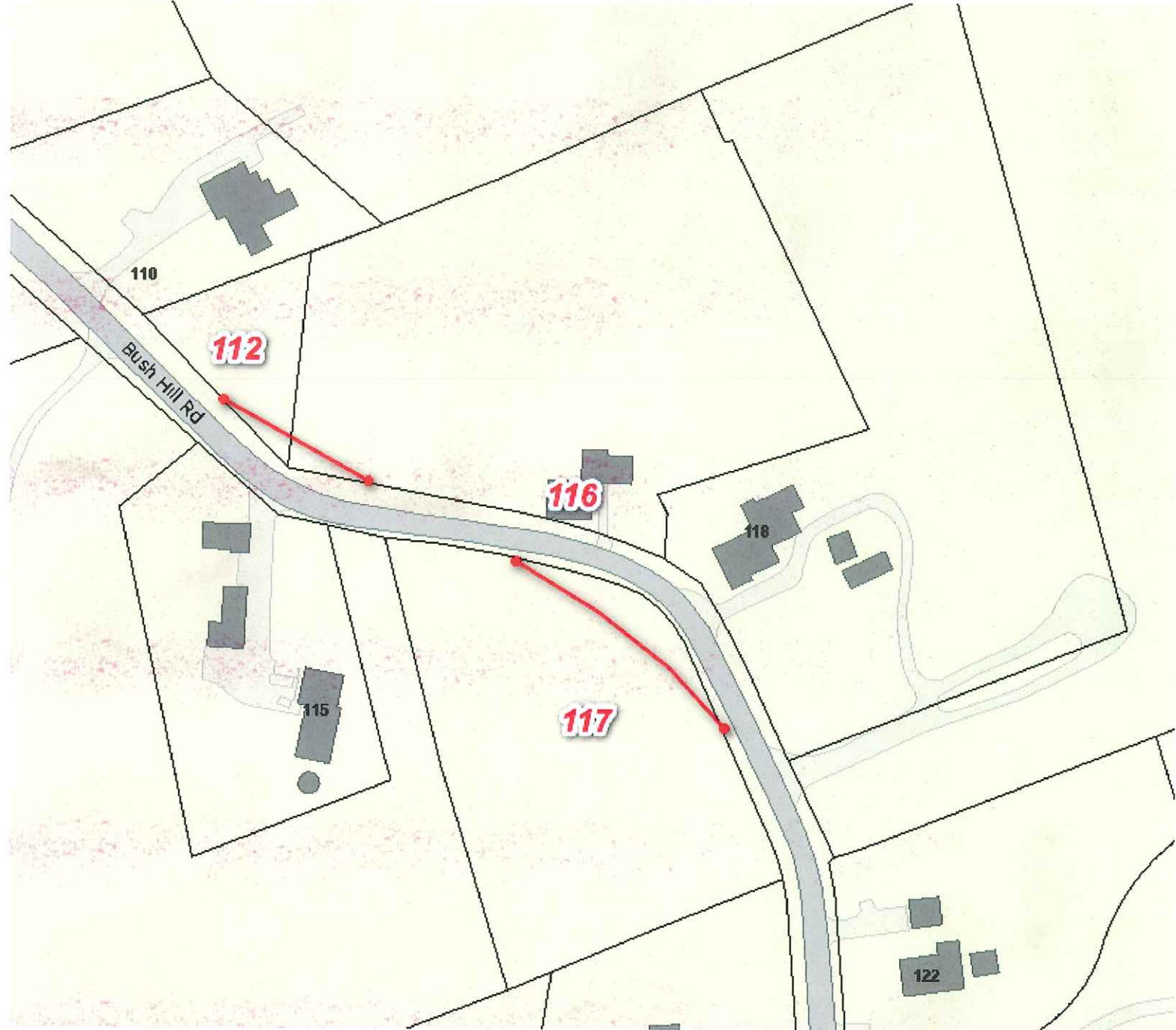

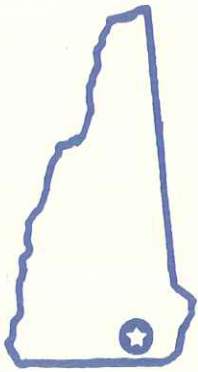

TOWN OF HUDSON

Public Works

Agenda
3-22-22

2 Constitution Drive Hudson, New Hampshire 03051 603/886-6018 Fax 603/594-1143



RECEIVED

MAR 17 2022

TOWN OF HUDSON
SELECTMEN'S OFFICE

8E

To: Board of Selectmen
From: Jess Forrence Public Works Director
Date: March 17, 2022
Re: Town Wide Paving Contract

I have received an offer from Brox Industries to extend our town wide paving contract again this year. The current pricing is \$69.98 per ton to supply and install hot bituminous asphalt. In their FY2023 contract, due to the ever increasing prices of liquid asphalt, fuel and labor, Brox has proposed a \$2.47 per ton increase to \$72.45 per ton on hot asphalt. This represents a 0.035% increase over last year.

The current price for cold planing and reclaiming are \$1.35 per square yard and \$1.36 per square yard respectively. Brox is proposing a \$0.30 increase for cold planing to \$1.65 per square yard and a \$0.39 increase to \$1.75 per square yard for reclaiming. This will be the first increase for these items since 2010.

After doing some research on current pricing I strongly recommend we accept this offer.

Recent bids in the area that I have located include Nashua, which is paying \$75.00 per ton for main roads and \$72.00 per ton for residential roads to furnish and install hot bituminous asphalt, which averages out to \$73.50 per ton. \$2.05 per square yard for cold planing and \$3.60 per square yard for reclaiming.

In comparison to Nashua, a community that bids more than six times the tonnage that we do, we will be paying \$1.05 per ton less on average for main and residential roads combined, for asphalt, \$.40 per square yard less for cold planing, and \$1.85 a square yard less for reclaiming.

Looking at these numbers it may not seem like much of a cost savings, But using the amount of asphalt we purchased in FY2021 and the amount of square yards of cold planing and reclaiming we did, the savings is significant. If we had to pay the same prices Nashua does, to complete the same amount of work in FY2023 as we did in FY2022 it would cost over \$115,000.00 more.

One more difference worth noting is, our existing contract, other than the 3 cost items noted above, is all inclusive. This means there are no other cost items that are in other neighboring town and city contracts like trimming pavement joints and driveways, emulsion application, sweeping, handwork, separate pricing for different asphalt mix designs, and separate pricing for residential and main roads. These items, if listed separately, would dramatically increase our costs.

In closing, Brox has been a long time, loyal and trust worthy contractor for the Town of Hudson. They have always completed the work on time and in a professional manner. They do quality work and back up their work. It is my recommendation that we accept this offer to extend the Town Wide Paving contact for FY23. It is my recommendation that we waive the bid process and accept their offer to extend the Town Wide Paving contact for the FY23.

Cc. Lisa Labrie, Finance Director

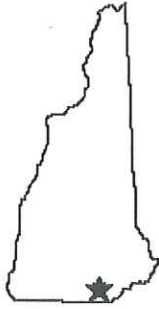

TOWN OF HUDSON FIRE DEPARTMENT

39 FERRY STREET, HUDSON, NEW HAMPSHIRE 03051



*Agenda
3-22-22*

8F

Emergency 911
Business 603-886-6021
Fax 603-594-1164

Robert M. Buxton
Chief of Department

TO: Marilyn McGrath
Chairman

FR: Robert M. Buxton
Fire Chief

RMB

DT: March 16, 2022

RE: Radio Replacement - March 22, 2022 BOS Public Agenda

RECEIVED
MAR 17 2022
TOWN OF HUDSON
SELECTMEN'S OFFICE

I am happy to report that we have set the final schedule for the radio infrastructure project the Board of Selectmen have funded. We are anticipating the new towers, antennas and microwave systems to be operational by July 1, 2022.

As we prepare to move the Public Works Department from a low band system to a high band frequency, we need to move forward with the purchase of mobile radios and base station equipment. This project will be a large improvement to the Public Works operation and employee safety programs.

The upgrade to the Public Works facility will also allow for improved interoperability between Public Works, Police and Fire Departments. Additionally, it will allow us the opportunity to expand our communication program in the area of Emergency Management. Currently, this functionality does not exist between all three departments.

The following is a breakdown of the costing associated with this project;

- Fleet Radios \$37,179.81
- Facilities \$37,776.81
- Associated Installation \$6,000.00
- o Total \$80,956.62

Additionally, we are requesting the Board of Selectmen purchase two additional mobile radios for the fire department. This request is being added as our current communication program is attempting to operate under the default budget constraints.

The following is a cost for this project;

- Fleet Radios \$10,500.00

We are requesting the Board of Selectmen utilize the Communications Equipment and Infrastructure Capital Reserve Fund to fund both of the mentioned projects. The capital reserve

fund was established in 2013 for this purpose, with the Board of Selectmen as the agents to expend.

It is important to note that the lead time on purchasing is significant. We are anticipating this project being completed as the infrastructure project is coming on line in July.

Motion;

To authorize the purchase of the listed radio equipment for the Public Works and Fire Departments. Funding to come from the Communications Equipment and Infrastructure Capital Reserve Fund for a total of \$91,456.62.

Town of Hudson, NH
Capital Reserve/Trust Funds
Fiscal Year 2023

Date of Creation	Fund	Department	Name of Trust	Market Value Balance 6/30/2021	Budgeted Additions FY22	Anticipated Withdrawals FY22	Anticipated Withdrawals FY23	FY22 Projected Balance before Expenditures	Agents/ Authority to Expend	Town Proposed FY2023
19-Aug-94	GF	5750-450	Ambulance CRF	70,728				70,728	Vote	
10-Mar-98	GF		Benson's Land CRF	110,893				110,893	BOS	
12-Mar-13	GF	5940-450	Communications Equip & Infrastructure	957,023		(659,000)		298,023	BOS	
13-Mar-01	GF		Conservation Land CRF	858,597				858,597	Vote	
16-Jun-94	GF	5940-450	Employees Earned Time	975,334				975,334	BOS	
10-Mar-20	GF		Energy Efficiency CRF	28,430				28,430	BOS	
14-Mar-00	GF	5730-450	Fire Apparatus CRF	266,494		(170,000)		96,494	Vote	
11-Mar-08	GF	5730-450	Fire Apparatus Refurb & Repair CRF	249,455	25,000	(139,781)		134,674	BOS	
08-Mar-11	GF	5730-450	Fire Equipment CRF	8,512				8,512	BOS	
11-Mar-08	GF	5410-450	Future Property Revaluations CRF	263,404	15,000	(175,100)		103,304	BOS	
09-Mar-21	LIB		Hills Mem Library Maintenance CRF	0	25,000			25,000	BOS	
14-Mar-06	GF	5330/5677	Information Services CRF	87,458				87,458	BOS	
14-Mar-17	GF	5060-450	Library Improvements CRF	59,243				59,243	Vote	
11-Mar-14	GF	5045-450	Major Repair to Town Buildings CRF	153,506	50,000			203,506	BOS	
18-Mar-95	SF	5564-450	Nashua WWT CRF	4,096,668				4,096,668	BOS	
13-Mar-07	GF	5630-450	Police Bullet Proof Vest Repl CRF	52,096				52,096	BOS	
13-Mar-07	GF	5630-450	Police Duty Weapons Repl CRF	53,184				53,184	BOS	
09-Mar-21	GF	5630-450	Police Safety Equip CRF (Tasers/Cameras)	0	50,000			50,000	BOS	
09-Mar-10	GF/CC	5586-450	Pond Reclamation CRF	70,813				70,813	BOS	
12-Mar-02	GF	5810-450	Rec Facility Land Purchase CRF	237,064				237,064	Vote	
11-Mar-14	GF	5810-450	Recreation Equipment CRF	2,105				2,105	BOS	
11-Mar-14	GF	5824-450	Recreation Field Construction CRF	1,526				1,526	BOS	
28-Nov-97	SF		Sewer Capital Assessment	10,500,217				10,500,217	BOS	
16-Sep-95	SF	5564-450	Sewer Pump Repair CRF	201,051				201,051	BOS	
14-Mar-06	GF/SF	5554/5562-450	VacCon Truck Replacement CRF	393,286	60,000	(400,000)		53,286	Vote	
12-Mar-02	WF	5592-450	Water Utility Improvement CRF	4,055,498				4,055,498	BOS	
12-Mar-02	WF	5592-450	Water Utility Capital Repair CRF	447,707				447,707	BOS	
08-Mar-16	WF	5592-450	Water Utility Infrastructure & Capital CRF	87,038				87,038	BOS	
			BOS = Board of Selectmen	24,287,330	225,000	(1,543,881)	-	22,968,449		0
			Trustees = Trustees of the Trust Fund							
			Vote = Town Meeting Vote				SF	14,797,936		
			LIB = Library Trustees				WF	4,590,243		
							LIB	25,000		

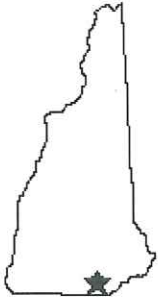

TOWN OF HUDSON MODERATOR

RECEIVED
MAR 16 2022
TOWN OF HUDSON
SELECTMEN'S OFFICE



Agenda
3-22-22

12 School Street • Hudson, New Hampshire 03051 • Tel: 603-886-6024 • Fax: 603-598-6481

8G

March 16, 2022

To: Board of Selectmen

Ladies and Gentlemen,

Attached are the statistics for the Town and School Elections. We had a 27.1% voter turnout, the largest in a number of years. This was the first time we voted in two locations and the process of set up and take down went smoothly. While both locations had a steady stream of voters, we did not experience any long lines at check-in. Due to the length of the ballots, there were occasional backups of voters waiting for a booth to open and in checking out at the ballot boxes. I did not hear of any problems with access to the buildings or parking. Our Ballot Clerks processed averages of 175 voters per hour at the Community Center and 153 at Alvirne.

I must commend my hard working staff for their efforts, the Town and Alvirne custodial staff for their assistance, and the Hudson Women's Club and Alvirne's Culinary Arts Department for providing dinners for the workers. The staff of the DPW efficiently set up and took down both polling places, especially at Alvirne where they came back at the end of the night so the cafeteria could be reset for the next school day.

As we look ahead, there will be three elections coming up: A September Primary, A State General Election, and next March's Town and School Elections. Although we will be operating under a default budget, I hope the Board will be able to provide funds for the electronic poll books that were requested in the FY 23 budget. As a growing Town, I believe that we need the efficiency that the poll books will provide both to the check-in process and the statistical reports need at the end of the elections. Please let me know if you have any questions.

Paul Inderbitzen

Moderator

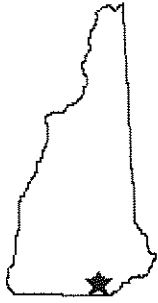

TOWN OF HUDSON MODERATOR



12 School Street • Hudson, New Hampshire 03051 • Tel: 603-886-6024 • Fax: 603-598-6481

MARCH 8, 2022 TOWN AND SCHOOL ELECTION STATISTICS

Number of Voters per Hour

TIME	MACHINE COUNTS Ward 1	TOTAL	MACHINE COUNTS Ward 2	TOTAL
7-8	115	115	95	95
8-9	251	136	200	105
9-10	412	161	328	128
10-12	624	212	485	157
12-1	859	235	662	177
1-2	1058	199	781	119
2-3	1224	166	927	146
3-4	1377	153	1118	191
4-5	1565	188	1273	155
5-6	1817	252	1483	210
6-7	2014	197	1674	191
7-8	2275	261	1875	201
Final			1984	109
TOTAL	2275		1984	
	AVE/HR	175	AVE/HR	153

Number of Check-ins per Book

CHECK-IN BOOK	TOTAL
WARD 1	
A - D	623
E - K	450
L - Q	631
R - Z	516
New Voter Cards	51
TOTAL	2271
WARD 2	
A - D	543
E - K	426
L - P	568
Q - Z	411
New Voter Cards	42
TOTAL	1990
GRAND TOTAL	4261

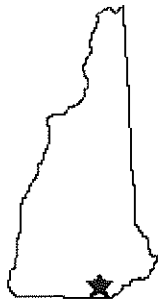

TOWN OF HUDSON MODERATOR



12 School Street • Hudson, New Hampshire 03051 • Tel: 603-886-6024 • Fax: 603-598-6481

TOWN OF HUDSON VOTER PARTICIPATION AT TOWN/SCHOOL ELECTIONS

Date	Ballots Cast	Absentee	New Registrations	Total Checklist	%	Issues Effecting Turnout
March 2023						
March 2022	4259	121	93	15,713	27.1	Police Facility Bond, Zoning Petitions, School Petitions
March 2021	3031	234	18	20,325	14.9	High School Renovation Bond, Police Renovation Bond, Teacher Contract.
March 2020	4156	101	98	18,974	21.9	High School Renovation Bond, Police Renovation Bond, 4 Union Contracts.
March 2019	4539	144	134	18,597	24.4	High School Renovation Bond; Full day Kindergarten; 4 Union Contracts
March 2018	3167	137	109	18,056	17.5	2 High School Construction Bonds
March, 2017	2534	69	23	16,763	15.1	Fire Station build; Police & Highway Employee contracts; School Leadership contract
March 2016	3754	78	72	16,691	22.5	Fire Station Bond; Firefighters contract; Teachers & Administrators contract; HS Track
March 2015	2748	46	65	16,061	17.1	Fire Station Bond & renovation; Police, Fire, & Town Supervisors contract; HS Track Bond; School Leadership contract.
March 2014	3620	53	162	15,763	23.0	Police, Fire & Highway Employee contracts; Police, Fire, & Town Supervisors contract; Teachers & Principals/Dept. Heads contracts
March. 2013	3238	49	76	15,565	20.8	Police, Fire, & Highway contracts; Town Supervisors contract; Senior Center Construction; Teacher contract
March, 2012	2340	52	45	13,941	16.8	Town Supervisors contract; Support Union contract;
March, 2011	2560	41		16,435	15.6	Town Supervisors contract;

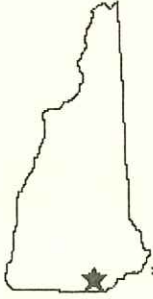

TOWN OF HUDSON
Finance Department

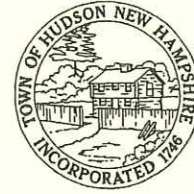

Agenda
3-22-22

8H

12 School Street • Hudson, New Hampshire 03051 • Tel: 603-886-6000 • Fax: 603 881-3944

RECEIVED

MAR 17 2022

TOWN OF HUDSON
SELECTMEN'S OFFICE

To: Board of Selectmen
Steve Malizia, Town Administrator

From: Lisa Labrie, Finance Director *LL*

Date: March 17, 2022

Subject: Police – Purchase of a 2022 Ford Police Utility Vehicle

Please accept this recommendation to be placed on the Board of Selectmen's next agenda.

Recommendation:

I agree with the recommendation of the Police Chief to purchase 1 Ford Police Utility Interceptor. I also agree with waiving the bid process as the Town of Hudson will be using the vendor who won the State of NH's bid and will receive the same discount.

Funding: The Police Department has \$180,000.00 in the fiscal year 2022 Police Automobile budget 5630-402 for the purchase of these vehicles.

Motion 1:

To waive the competitive bidding requirements as outlined in Hudson Town Code 98-1C as the Police Department will use the State of NH's bid winner for 2022.

Motion 2:

To purchase one (1) Ford Police Utility Vehicles in the amount of \$32,335.00 from McFarland Ford in Exeter, NH. As recommended by the Police Chief and Finance Director. This does not include the cost of fitting up the vehicle with existing and new equipment.

Cc: Tad Dionne, Police Chief

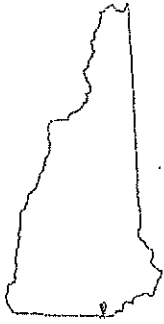

TOWN OF HUDSON

Police Department

Partners with the Community

1 Constitution Drive, Hudson, New Hampshire 03051
Voice/TTY (603) 886-6011/Crime Line (603) 594-1150/Fax (603) 594-1162

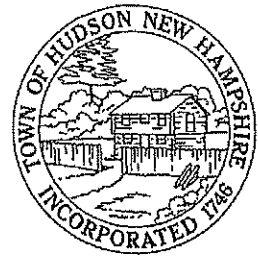

*Tad K. Dionne
Chief of Police*

*Captain David A. Cayot
Special Investigations Bureau*

*Captain David A. Bianchi
Administrative Bureau*

*Captain Michael P. Davis
Operations Bureau*

To: The Board of Selectmen
Steve Malizia, Town Administrator

From: Tad K. Dionne, Chief of Police

Date: 14 March 2022

Re: Agenda Item

Scope:

The Police Department is requesting to meet with the Board of Selectmen at their 22 March 2022 meeting to respectfully ask the Board of Selectman to waive the bidding process and allow us to purchase one (1) police utility vehicle from the winner of the New Hampshire 2022 vehicle bids. The winner of the 2022 vehicle bids for New Hampshire was McFarland Ford in Exeter New Hampshire. The purchasing of the vehicle would be from the current FY22 Budget. The bids close on April 30th, 2022 at which time no more 2022 vehicles can be ordered.

The vehicle is available for a cost of \$32,335.00. Payment is not due until delivery and we are being advised the vehicles if ordered now would not be delivered until mid-September at a minimum. We would encumber the money until that time.

Motion:

To accept the Police Department's recommendation to purchase one (1) police utility vehicle from McFarland Ford in Exeter New Hampshire in the amount of \$32,335.00. This does not include the cost of up fitting the vehicle with existing and new equipment.



A NATIONALLY ACCREDITED LAW ENFORCEMENT AGENCY

Prepared for: , HUDSON PD

2022 Police Interceptor Utility AWD Base (K8A)

Price Level: 220



Client Proposal

Prepared by:

Eric Cummings

Office: 603-772-5953

Quote ID: HUDSON

Date: 03/14/2022



McFarland Ford Sales, Inc. | 151 Portsmouth Ave, Exeter, New Hampshire, 038332186

Office: 603-772-5953

Prepared for:

HUDSON PD

Prepared by: Eric Cummings

03/14/2022



McFarland Ford Sales, Inc. | 151 Portsmouth Ave Exeter New Hampshire | 038332186

2022 Police Interceptor Utility AWD Base (K8A)

Price Level: 220 | Quote ID: HUDSON

As Configured Vehicle

Code	Description	MSRP
Base Vehicle		
K8A	Base Vehicle Price (K8A)	\$41,110.00
Packages		
500A	Order Code 500A <i>Includes:</i> - 3.73 Axle Ratio - GVWR: 6,840 lbs (3,103 kgs) - Tires: 255/60R18 AS BSW - Wheels: 18" x 8" 5-Spoke Painted Black Steel Includes polished stainless steel hub cover and center caps. - Unique HD Cloth Front Bucket Seats w/Vinyl Rear Includes reduced bolsters, driver 6-way power track (fore/aft, up/down, tilt with manual recline, 2-way manual lumbar), passenger 2-way manual track (fore/aft, with manual recline) and built-in steel intrusion plates in both driver/passenger seatbacks. - Radio: AM/FM/MP3 Capable Includes clock, 4-speakers, Bluetooth interface with hands-free voice command support (compatible with most Bluetooth connected mobile devices), 1 USB port and 4.2" color LCD screen center stack smart display.	N/C
Powertrain		
99B	Engine: 3.3L V6 Direct-Injection (FFV) <i>(136-MPH top speed). Note: Deletes regenerative braking and lithium-ion battery pack; adds 250-Amp alternator, replaces H7 AGM battery (800 CCA/80-amp) with H7 SLI battery (730 CCA/80-amp) and replaces 19-gallon tank with 21.4-gallon.</i>	-\$3,370.00
44U	Transmission: 10-Speed Automatic (44U)	N/C
STDAX	3.73 Axle Ratio	Included
STDGV	GVWR: 6,840 lbs (3,103 kgs)	Included
Wheels & Tires		
STDTR	Tires: 255/60R18 AS BSW	Included
STDWL	Wheels: 18" x 8" 5-Spoke Painted Black Steel <i>Includes polished stainless steel hub cover and center caps.</i>	Included
Seats & Seat Trim		
9	Unique HD Cloth Front Bucket Seats w/Vinyl Rear	Included

Prices and content availability as shown are subject to change and should be treated as estimates only. Actual base vehicle, package and option pricing may vary from this estimate because of special local pricing, availability or pricing adjustments not reflected in the dealer's computer system. See salesperson for the most current information.

Prepared for:

HUDSON PD

Prepared by: Eric Cummings

03/14/2022



McFarland Ford Sales, Inc. | 151 Portsmouth Ave Exeter New Hampshire | 038332186

2022 Police Interceptor Utility AWD Base (K8A)

Price Level: 220 | Quote ID: HUDSON

As Configured Vehicle (cont'd)

Code	Description	MSRP
	<i>Includes reduced bolsters, driver 6-way power track (fore/aft. up/down, tilt with manual recline, 2-way manual lumbar), passenger 2-way manual track (fore/aft. with manual recline) and built-in steel intrusion plates in both driver/passenger seatbacks.</i>	

Other Options

PAINT	Monotone Paint Application	STD
119WB	119" Wheelbase	STD
STDRD	Radio: AM/FM/MP3 Capable <i>Includes clock, 4-speakers, Bluetooth interface with hands-free voice command support (compatible with most Bluetooth connected mobile devices), 1 USB port and 4.2" color LCD screen center stack smart display.</i>	Included
153	Front License Plate Bracket	N/C
43D	Dark Car Feature <i>Courtesy lamps disabled when any door is opened.</i>	\$25.00
60A	Grille LED Lights, Siren & Speaker Pre-Wiring	\$50.00
51R	Driver Only LED Spot Lamp (Unity)	\$395.00
59B	Keyed Alike - 1284x	\$50.00
549	Heated Sideview Mirrors	\$60.00
76R	Reverse Sensing System	\$275.00

Emissions

425	50 State Emission System Flexible Fuel Vehicle (FFV) system is standard equipment for vehicles equipped with the 3.3L V6 Direct-Injection engine.	STD
-----	--	-----

Interior Color

96_01	Charcoal Black w/Unique HD Cloth Front Bucket Seats w/Vinyl Rear	N/C
-------	---	-----

Exterior Color

UM_01	Agate Black	N/C
-------	-------------	-----

SUBTOTAL	\$38,595.00
Destination Charge	\$1,245.00

Prices and content availability as shown are subject to change and should be treated as estimates only. Actual base vehicle, package and option pricing may vary from this estimate because of special local pricing, availability or pricing adjustments not reflected in the dealer's computer system. See salesperson for the most current information.

Prepared for:

HUDSON PD

Prepared by: Eric Cummings

03/14/2022



McFarland Ford Sales, Inc. | 151 Portsmouth Ave Exeter New Hampshire | 038332186

2022 Police Interceptor Utility AWD Base (K8A)

Price Level: 220 | Quote ID: HUDSON

As Configured Vehicle (cont'd)

Code	Description	MSRP
TOTAL		\$39,840.00

Prices and content availability as shown are subject to change and should be treated as estimates only. Actual base vehicle, package and option pricing may vary from this estimate because of special local pricing, availability or pricing adjustments not reflected in the dealer's computer system. See salesperson for the most current information.

Prepared for:

HUDSON PD

Prepared by: Eric Cummings

03/14/2022



McFarland Ford Sales, Inc. | 151 Portsmouth Ave Exeter New Hampshire | 038332186

2022 Police Interceptor Utility AWD Base (K8A)

Price Level: 220 | Quote ID: HUDSON

Pricing Summary - Single Vehicle

	MSRP
<i>Vehicle Pricing</i>	
Base Vehicle Price	\$41,110.00
Options	-\$2,515.00
Colors	\$0.00
Upfitting	\$0.00
Fleet Discount	\$0.00
Fuel Charge	\$0.00
Destination Charge	\$1,245.00
Subtotal	\$39,840.00

Pre-Tax Adjustments

Code	Description	MSRP
STATE BID DISCO	STATE BID DISCOUNT	-\$7,505.00
Total		\$32,335.00

Customer Signature

Acceptance Date

Prices and content availability as shown are subject to change and should be treated as estimates only. Actual base vehicle, package and option pricing may vary from this estimate because of special local pricing, availability or pricing adjustments not reflected in the dealer's computer system. See salesperson for the most current information.

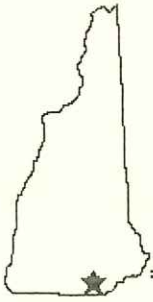

TOWN OF HUDSON

Finance Department

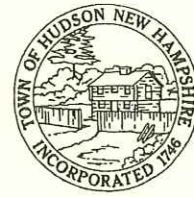

Agenda
3-22-22

8I

12 School Street • Hudson, New Hampshire 03051 • Tel: 603-886-6000 • Fax: 603 881-3944

RECEIVED

MAR 17 2022

TOWN OF HUDSON
SELECTMEN'S OFFICE

To: Board of Selectmen
Steve Malizia, Town Administrator

From: Lisa Labrie, Finance Director *LL*

Date: March 17, 2022

Subject: Police – Purchase of four (4) 2022 Ford Police Utility Vehicles

Please accept this recommendation to be placed on the Board of Selectmen's next agenda.

Recommendation:

I agree with the recommendation of the Police Chief to purchase 4 Ford Police Utility Interceptors. I also agree with waiving the bid process as the Town of Hudson will be using the vendor who won the State of NH's bid and will receive the same discount.

Funding: The Police Department has \$180,000.00 in the fiscal year 2023 Police Automobile budget 5630-402 for the purchase of these vehicles.

Delivery and payment of vehicles are not to be made until July 1, 2022 (FY23)

Notation: We, as a Town, have had great difficulty getting vehicles in a timely manner. It makes sense to order ahead.

Motion 1:

To waive the competitive bidding requirements as outlined in Hudson Town Code 98-1C as the Police Department will use the State of NH's bid winner for 2022.

Motion 2:

To purchase four (4) Ford Police Utility Vehicles in the amount of \$103,840.00 from McFarland Ford in Exeter, NH. As recommended by the Police Chief and Finance Director. This does not include the cost of fitting up the vehicles with existing and new equipment.

Cc: Tad Dionne, Police Chief



TOWN OF HUDSON

Police Department

Partners with the Community

1 Constitution Drive, Hudson, New Hampshire 03051
Voice/TTY (603) 886-6011/Crime Line (603) 594-1150/Fax (603) 594-1162



*Tad K. Dionne
Chief of Police*

*Captain David A. Cayot
Special Investigations Bureau*

*Captain David A. Bianchi
Administrative Bureau*

*Captain Michael P. Davis
Operations Bureau*

To: The Board of Selectmen
Steve Malizia, Town Administrator

From: Tad K. Dionne, Chief of Police

Date: 14 March 2022 ⁽¹⁵⁾

Re: Agenda Item

Scope:

The Police Department is requesting to meet with the Board of Selectmen at their 22 March 2022 meeting to respectfully ask the Board of Selectman to waive the bidding process and allow us to purchase four (4) police Utility Vehicles from the winner of the New Hampshire 2022 vehicle bids. The winner of the 2022 vehicle bids for New Hampshire was McFarland Ford in Exeter New Hampshire. The purchasing of the vehicles would be from the FY23 Budget. There is a vehicle shortage due to high demand and lack of sufficient production the past two years. The bids close on April 30th, 2022 at which time no more vehicles can be ordered. We feel if we do not order now we will not be able to obtain replacement vehicles this year.

The vehicles are available with trade values considered for a cost of \$103,840.00. Payment is not due until delivery and we are being advised the vehicles if ordered now would not be delivered until mid-September at a minimum.

Motion:

To accept the Police Department's recommendation to purchase four (4) police utility vehicles from McFarland Ford in Exeter New Hampshire in the amount of \$103,840.00. This does not include the cost of up fitting the vehicles with existing and new equipment.



A NATIONALLY ACCREDITED LAW ENFORCEMENT AGENCY

Prepared for: , HUDSON PD

2022 Police Interceptor Utility AWD Base (K8A)

Price Level: 220



Client Proposal

Prepared by:

Eric Cummings

Office: 603-772-5953

Quote ID: HUDSON

Date: 03/03/2022



McFarland Ford Sales, Inc. | 151 Portsmouth Ave, Exeter, New Hampshire, 038332186

Office: 603-772-5953

Prepared for:

HUDSON PD

Prepared by: Eric Cummings

03/03/2022



McFarland Ford Sales, Inc. | 151 Portsmouth Ave Exeter New Hampshire | 038332186

2022 Police Interceptor Utility AWD Base (K8A)

Price Level: 220 | Quote ID: HUDSON

As Configured Vehicle

Code	Description	MSRP
Base Vehicle		
K8A	Base Vehicle Price (K8A)	\$41,110.00
Packages		
500A	Order Code 500A <i>Includes:</i> - 3.73 Axle Ratio - GVWR: 6,840 lbs (3,103 kgs) - Tires: 255/60R18 AS BSW - Wheels: 18" x 8" 5-Spoke Painted Black Steel <i>Includes polished stainless steel hub cover and center caps.</i> - Unique HD Cloth Front Bucket Seats w/Vinyl Rear <i>Includes reduced bolsters, driver 6-way power track (fore/aft, up/down, tilt with manual recline, 2-way manual lumbar), passenger 2-way manual track (fore/aft, with manual recline) and built-in steel intrusion plates in both driver/passenger seatbacks.</i> - Radio: AM/FM/MP3 Capable <i>Includes clock, 4-speakers, Bluetooth interface with hands-free voice command support (compatible with most Bluetooth connected mobile devices), 1 USB port and 4.2" color LCD screen center stack smart display.</i>	N/C
Powertrain		
99B	Engine: 3.3L V6 Direct-Injection (FFV) <i>(136-MPH top speed). Note: Deletes regenerative braking and lithium-ion battery pack; adds 250-Amp alternator, replaces H7 AGM battery (800 CCA/80-amp) with H7 SLI battery (730 CCA/80-amp) and replaces 19-gallon tank with 21.4-gallon.</i>	-\$3,370.00
44U	Transmission: 10-Speed Automatic (44U)	N/C
STDAX	3.73 Axle Ratio	Included
STDGV	GVWR: 6,840 lbs (3,103 kgs)	Included
Wheels & Tires		
STDTR	Tires: 255/60R18 AS BSW	Included
STDWL	Wheels: 18" x 8" 5-Spoke Painted Black Steel <i>Includes polished stainless steel hub cover and center caps.</i>	Included
Seats & Seat Trim		
9	Unique HD Cloth Front Bucket Seats w/Vinyl Rear	Included

Prices and content availability as shown are subject to change and should be treated as estimates only. Actual base vehicle, package and option pricing may vary from this estimate because of special local pricing, availability or pricing adjustments not reflected in the dealer's computer system. See salesperson for the most current information.

Prepared for:

HUDSON PD

Prepared by: Eric Cummings

03/03/2022



McFarland Ford Sales, Inc. | 151 Portsmouth Ave Exeter New Hampshire | 038332186

2022 Police Interceptor Utility AWD Base (K8A)

Price Level: 220 | Quote ID: HUDSON

As Configured Vehicle (cont'd)

Code	Description	MSRP
	<i>Includes reduced bolsters, driver 6-way power track (fore/aft, up/down, tilt with manual recline, 2-way manual lumbar), passenger 2-way manual track (fore/aft, with manual recline) and built-in steel intrusion plates in both driver/passenger seatbacks.</i>	

Other Options

PAINT	Monotone Paint Application	STD
119WB	119" Wheelbase	STD
STDRD	Radio: AM/FM/MP3 Capable <i>Includes clock, 4-speakers, Bluetooth interface with hands-free voice command support (compatible with most Bluetooth connected mobile devices), 1 USB port and 4.2" color LCD screen center stack smart display.</i>	Included
153	Front License Plate Bracket	N/C
43D	Dark Car Feature <i>Courtesy lamps disabled when any door is opened.</i>	\$25.00
60A	Grille LED Lights, Siren & Speaker Pre-Wiring	\$50.00
51R	Driver Only LED Spot Lamp (Unity)	\$395.00
59B	Keyed Alike - 1284x	\$50.00
549	Heated Sideview Mirrors	\$60.00
76R	Reverse Sensing System	\$275.00

Emissions

425	50 State Emission System Flexible Fuel Vehicle (FFV) system is standard equipment for vehicles equipped with the 3.3L V6 Direct-Injection engine.	STD
-----	--	-----

Interior Color

96_01	Charcoal Black w/Unique HD Cloth Front Bucket Seats w/Vinyl Rear	N/C
-------	---	-----

Exterior Color

UM_01	Agate Black	N/C
-------	-------------	-----

SUBTOTAL	\$38,595.00
Destination Charge	\$1,245.00

Prices and content availability as shown are subject to change and should be treated as estimates only. Actual base vehicle, package and option pricing may vary from this estimate because of special local pricing, availability or pricing adjustments not reflected in the dealer's computer system. See salesperson for the most current information.

Prepared for:

HUDSON PD

Prepared by: Eric Cummings

03/03/2022



McFarland Ford Sales, Inc. | 151 Portsmouth Ave Exeter New Hampshire | 038332186

2022 Police Interceptor Utility AWD Base (K8A)

Price Level: 220 | Quote ID: HUDSON

As Configured Vehicle (cont'd)

Code	Description	MSRP
TOTAL		\$39,840.00

Prices and content availability as shown are subject to change and should be treated as estimates only. Actual base vehicle, package and option pricing may vary from this estimate because of special local pricing, availability or pricing adjustments not reflected in the dealer's computer system. See salesperson for the most current information.

Prepared for:

HUDSON PD

Prepared by: Eric Cummings

03/03/2022



McFarland Ford Sales, Inc. | 151 Portsmouth Ave Exeter New Hampshire | 038332186

2022 Police Interceptor Utility AWD Base (K8A)

Price Level: 220 | Quote ID: HUDSON

Pricing Summary - Single Vehicle

	MSRP
<i>Vehicle Pricing</i>	
Base Vehicle Price	\$41,110.00
Options	-\$2,515.00
Colors	\$0.00
Upfitting	\$0.00
Fleet Discount	\$0.00
Fuel Charge	\$0.00
Destination Charge	\$1,245.00
Subtotal	\$39,840.00

Pre-Tax Adjustments

Code	Description	MSRP
STATE BID DISCO	STATE BID DISCOUNT	-\$7,505.00
TRADE 1	2017 INTERCEPTOR	-\$5,500.00
TRADE 2	2019 INTERCEPTOR	-\$10,000.00
TRADE 3	2019 INTERCEPTOR	-\$10,000.00
3	3 ADDL UNITS PER SPEC	\$97,005.00
Total		\$103,840.00

Customer Signature

Acceptance Date

Prices and content availability as shown are subject to change and should be treated as estimates only. Actual base vehicle, package and option pricing may vary from this estimate because of special local pricing, availability or pricing adjustments not reflected in the dealer's computer system. See salesperson for the most current information.

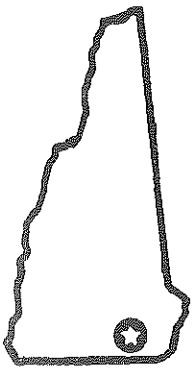

TOWN OF HUDSON
Office of the Town Administrator
12 School Street
Hudson, New Hampshire 03051



Agenda
3-22-22

Stephen A. Malizia, Town Administrator – smalizia@hudsonnh.gov – Tel: 603-886-6024 Fax: 603-598-6481

8J

To: Board of Selectmen

From: Steve Malizia, Town Administrator

Date: March 17, 2022

Re: Financing for Police Facility Expansion and Renovation

As you are all aware, Warrant Article 9 for the Police Facility Expansion and Renovation was approved by the voters. The warrant article authorized the Board of Selectmen to issue \$5,928,980 of bonds or notes for the project. I am recommending that the Board of Selectmen utilize the New Hampshire Municipal Bond Bank (NHMBB) for this bond. The NHMBB was established by the state legislature in 1977 as an independent unit of state government administered by a board of directors with a mission of providing access to low-cost tax-exempt financing for New Hampshire municipalities. The Town's outstanding water bonds are with the NHMBB. Utilizing the NHMBB will lower the Town's issuance cost of the bond as it bundles the financing needs of other NH communities thus spreading the cost of a single issue over several communities. The NHMBB's credit rating is determined by the underlying participants on the bond issue and the most recent interest rate for a 20 year bond issued by the NHMBB in January 2022 was 2.09%. Should the Board of Selectmen vote to accept my recommendation, the following motion is appropriate:

Motion: To authorize the application to the New Hampshire Municipal Bond Bank for the Police Facility Expansion and Renovation project bond.

Should you have any questions or need additional information, please feel free to contact me.

July 2022
Sale Schedule

NHMBB New Hampshire Municipal Bond Bank

MAY

S	M	T	W	T	F	S
					29	30
1	2	3	4	5	6	7
8	9	10	11	12	13	14
15	16	17	18	19	20	21
22	23	24	25	26	27	28
29	30	31				

JUNE

S	M	T	W	T	F	S
			1	2	3	4
5	6	7	8	9	10	11
12	13	14	15	16	17	18
19	20	21	22	23	24	25
26	27	28	29	30		

JULY

S	M	T	W	T	F	S
					1	2
3	4	5	6	7	8	9
10	11	12	13	14	15	16
17	18	19	20	21	22	23
24	25	26	27	28	29	30
31						

AUGUST

S	M	T	W	T	F	S
	1	2	3	4	5	6
7	8	9	10	11	12	13
14	15	16	17	18	19	20
21	22	23	24	25	26	27
28	29	30	31			

*Red Indicates Holidays

Friday, April 29 th	All Applications Due
Friday, May 6 th	Determine Maximum Loan Rates
Friday, May 6 th	Notify Bond Counsels of Identity of Governmental Units and Amount and Purposes of Municipal Bonds
Friday, May 6 th	Notify State Treasurer if Interested in State of NH Bond for Reserve Fund
Tuesday, May 10 th	All Legal Information from Participants Due to Their Bond Counsel
Tuesday, May 17 th	Bond Bank Board Reviews Applications and Mails Loan Agreements to Bond Counsels
Friday, May 20 th	Bond Counsels Mail Loan Agreements to Governmental Units and Clear Debt Schedules with the Bond Bank
Friday, May 20 th	Bond Counsels Send Preliminary Opinions to Ratings Agencies and the Bond Bank
June 6 – 10 th	Calls with Ratings Agencies
Friday, June 17 th	Deadline for Meeting of the Participants Governing Board for the Certificate of Vote
Monday, June 20 th	Loan Agreements Returned to Bond Bank
Wednesday, June 29 th	Preliminary Official Statements Mailed
Wednesday, July 13 th	Sale
Friday, July 15 th	Bond Counsels Mail Bonds to Governmental Units
Tuesday, July 26 th	Participants Return Bonds to Bond Counsel
Friday, July 29 th	Bond Counsels Mail Bonds to Locke Lord, LLC
August 9 – 10 th	Pre-Closing and Closing – Bond Proceeds Wired to Participants on August 10, 2022
Wednesday, August 10 th	Date of NHMBB Bonds and Interest Start Date
February 15, 2023	First Interest Payment
August 15, 2023	First Principal and Interest Payment

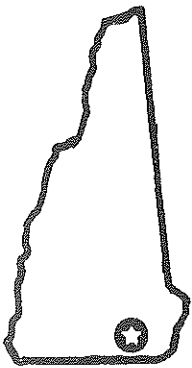

TOWN OF HUDSON
Office of the Town Administrator
12 School Street
Hudson, New Hampshire 03051

Agenda
3-22-22



Stephen A. Malizia, Town Administrator – smalizia@hudsonnh.gov – Tel: 603-886-6024 Fax: 603-598-6481

8K

To: Board of Selectmen

From: Steve Malizia, Town Administrator

Date: March 9, 2022

Re: NHDOT Project 43058 - Resurfacing Route 111

Attached please find correspondence from the New Hampshire Department of Transportation (NHDOT) notifying the Town that the NHDOT will be resurfacing Route 111 east of Burnham Road into Windham starting this spring and finishing in the fall. The NHDOT has forwarded a Municipal Work Zone Agreement (MWZA) for this project and they are asking the Town to sign the agreement acknowledging that the NHDOT will have the authority to control traffic through the work zone for the duration of this project. Should the Board of Selectmen agree to sign the acknowledgment, the following motion would be appropriate:

Motion: To approve the Municipal Work Zone Agreement (Project 43058) with the NHDOT for the resurfacing of Route 111, east of Burnham Road into Windham, and to authorize the Town Administrator to sign the agreement.

Should you have any questions or need additional information, please feel free to contact me.

Malizia, Steve

From: Grandmaison, Ronald <Ronald.J.Grandmaison@dot.nh.gov>
Sent: Tuesday, March 8, 2022 10:37 AM
To: Malizia, Steve
Subject: NHDOT Project Derry-Londonderry/Hudson-Windham 43058 - Town of Hudson Resurfacing
Attachments: 43058_MWZA_Hudson.docx; 43058_LocationMaps_Hudson.pdf

EXTERNAL: Do not open attachments or click links unless you recognize and trust the sender.

Mr. Malizia,

This is to notify the Town that the New Hampshire Department of Transportation (NHDOT) has developed a resurfacing project along NH Route 111 from a pavement joint east of Burnham Road in Hudson easterly to a pavement joint east of Church Road in Windham. This project is scheduled to begin construction this spring and be completed by the fall of 2022.

Work along NH Route 111 involves various pavement treatments and the replacement/installation of guardrail sections as needed within the project limits. Traffic control will involve the use of one-lane, alternating two-way traffic, lane shifts, and shoulder closures where necessary to complete the work, supplemented with flaggers or uniformed officers with vehicles.

Throughout the duration of the project, and at the discretion of the Department, uniformed officers and flaggers will be used to control traffic. Portable changeable message signs will be used to notify motorists in advance of upcoming work and provide messages during construction. All work on this project will be performed such that traffic is unimpeded whenever possible.

Included as part of this transmittal is a copy of the Municipal Work Zone Agreement (MWZA) that all municipalities are asked to sign as an acknowledgement that the Department will have the authority to control traffic through the work zone for the duration of the project. Please have a duly authorized official sign the attached document and return them to me via e-mail. A signed copy of the executed document will be returned to the Town and one retained in the Design file here in Concord.

If you have any questions or would like to discuss this project further, feel free to call me at 603-271-6198 or send an e-mail to Ronald.J.Grandmaison@dot.nh.gov.

Sincerely,

Ronald J. Grandmaison, PE

New Hampshire Department of Transportation
Bureau of Highway Design
Chief of Pavement Section
Phone: 603-271-6198
Fax: 603-271-7025
E-Mail: Ronald.J.Grandmaison@dot.nh.gov
Website: <http://www.nhdot.com>

The most dangerous phrase in our language is “We’ve always done it this way.”, Rear Admiral Grace Hopper



**MUNICIPAL WORK ZONE AGREEMENT
FOR
DERRY-LONDONDERRY/HUDSON-WINDHAM**

**STATE PROJECT: 43058
FEDERAL PROJECT: X-A005(025)**

THIS AGREEMENT, executed in *duplicate*, made and entered into this _____ day of _____ 2022, between the New Hampshire Department of Transportation, hereinafter called the "DEPARTMENT" and the Town of Hudson, hereinafter called the "TOWN."

WITNESSETH that,

WHEREAS, the DEPARTMENT will *resurface NH Route 111 from a pavement joint east of Burnham Road in Hudson easterly to a pavement joint east of Church Road in Windham;*

WHEREAS, The State Legislature has delegated the Commissioner of the DEPARTMENT with full authority to control traffic in highway/bridge construction work zones on Class I, II, and III highways; RSA 228:21, 236:1, and 228:37;

WHEREAS, The Department intends to use a combination of flaggers and/or uniformed officers, as appropriate, to control traffic and ensure public and worker safety; and

NOW, THEREFORE, in consideration of the above premises, it is mutually agreed as follows:

- A. The DEPARTMENT shall construct project *Derry-Londonderry/Hudson-Windham 43058, resurfacing a section of NH Route 111* in the TOWN.
- B. The DEPARTMENT will be responsible for the management and operation of the highway throughout the duration of the construction of the project. This includes the authority to determine the most appropriate way to control traffic within the construction work zone limits of the project.**
- C. The Department, as of April 1, 2013, will only compensate for the use of police officers that have successfully completed an NHDOT approved course on the Safe and Effective Use of Law Enforcement in Work Zones

IN WITNESS WHEREOF, the parties here have affixed their signatures, the Town of *Hudson*, New Hampshire, on this _____ day of _____, 2022; The Department of Transportation on this _____ day of _____, 2022.

**NEW HAMPSHIRE DEPARTMENT OF
TRANSPORTATION**

TOWN OF HUDSON

By: _____
Director of Project Development

By: _____
(*AUTHORIZED MUNICIPAL OFFICIAL*)

cc: Police Chief

43058 - DERRY-LONDONDERRY/HUDSON-WINDHAM

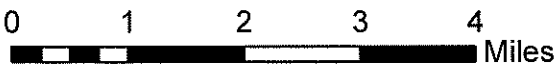
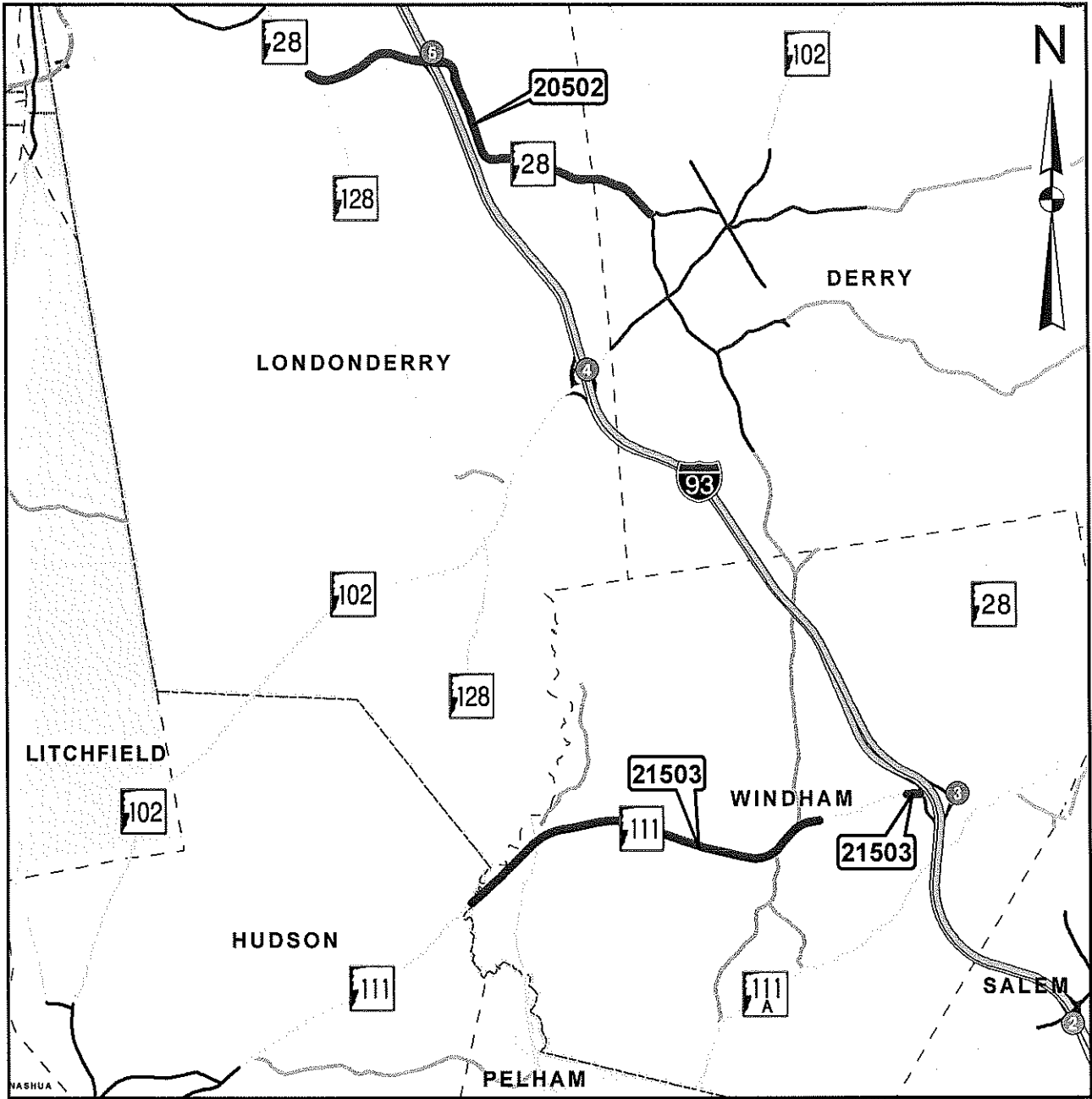

LEGEND

- 43058
- Urban Compacts
- Interstates
- State Routes
- Unnumbered Routes



State #: 43058
Federal #: X-A005(025)

LOCATION MAP

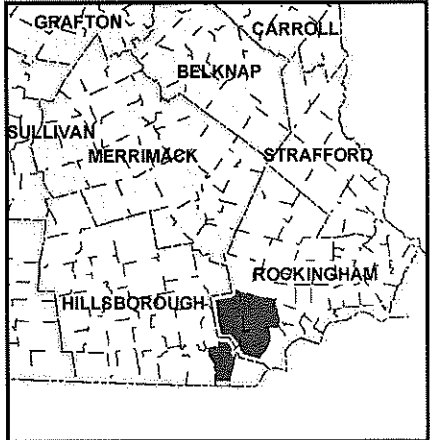

21503 - HUDSON - WINDHAM - NH 111

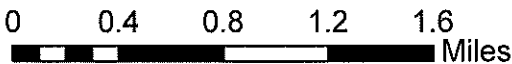
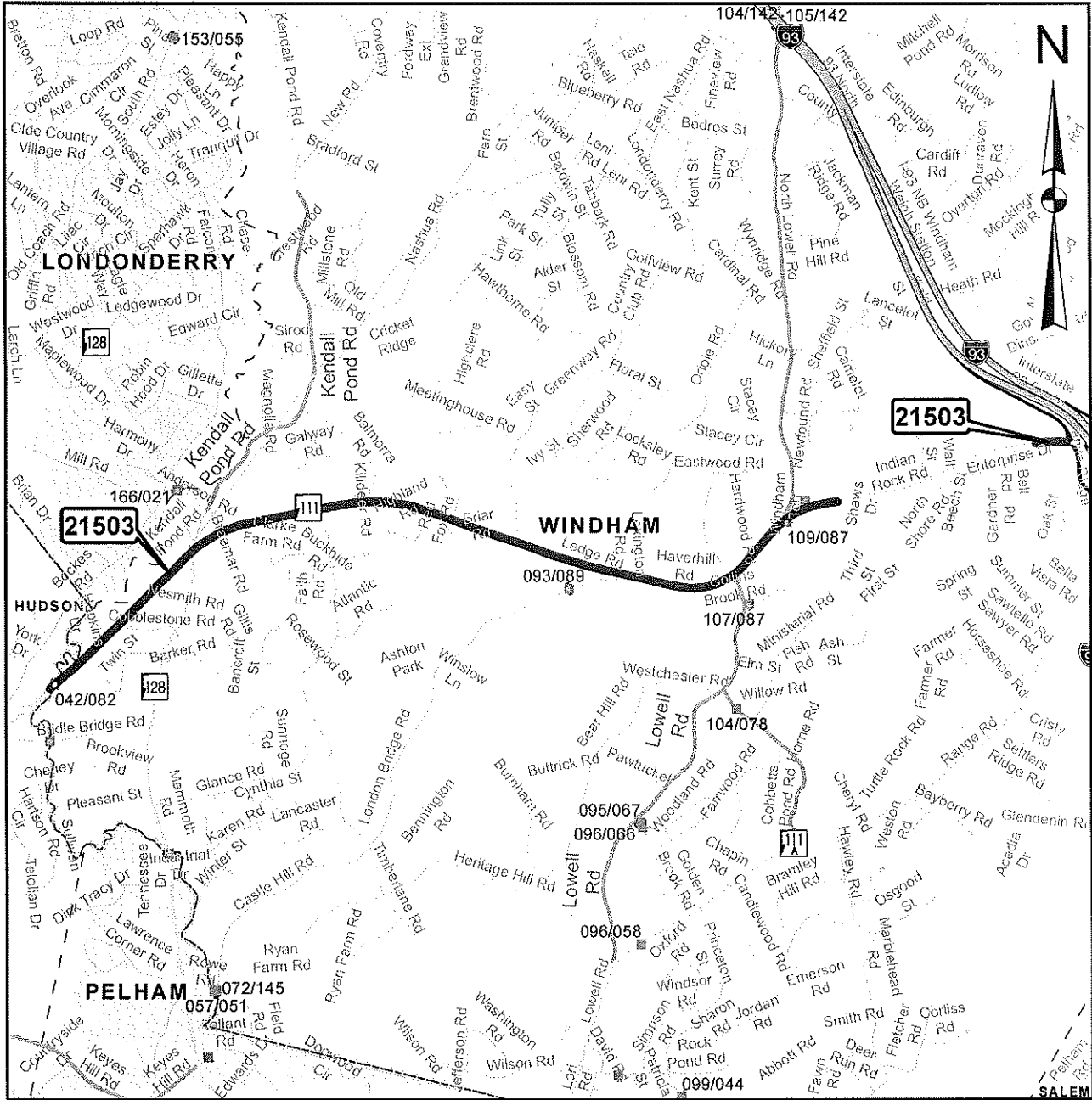

LEGEND	
	21503
	Interstates
	State Routes
	Unnumbered Routes

State #: 43058
Federal #: X-A005(025)

Paving ID: 21503
LOCATION MAP

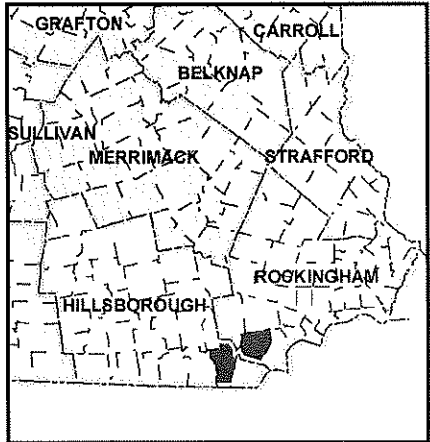

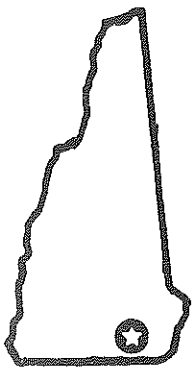

TOWN OF HUDSON
Office of the Town Administrator
12 School Street
Hudson, New Hampshire 03051



Agenda
3-22-22

Stephen A. Malizia, Town Administrator – smalizia@hudsonnh.gov – Tel: 603-886-6024 Fax: 603-598-6481

8L

To: Board of Selectmen

From: Steve Malizia, Town Administrator

Date: March 9, 2022

Re: VFW Post 5791 Loyalty Day Award Nomination

As part of its Annual Loyalty Day awards program, Hudson VFW Post 5791 has requested that the Board of Selectmen provide the name and biography of a Town employee, other than a member of the police and fire departments, who has made a contribution to the well being of the community.

This year, we would like to nominate Doreena Stickney for this award. Doreena is the Administrative Aide supporting the Engineering Department and has been employed by the Town since May 2013. Doreena always goes the extra mile helping residents and customers with their requests and concerns. Should the Board of Selectmen concur with this nomination, the following motion would be appropriate:

Motion: To nominate Doreena Stickney, Administrative Aide for the Engineering Department, for the 2022 Hudson VFW Post 5791 Loyalty Day Award.

Should this motion pass, I will forward the Board's nomination to the VFW in time for the proper arrangements to be made.

Should you have any questions or need additional information, please feel free to contact me.



HUDSON MEMORIAL POST NO. 5791
P.O. Box 430
Hudson, New Hampshire 03051-0430

RECEIVED

FEB 17 2022

TOWN OF HUDSON
SELECTMEN'S OFFICE

9 February 2022

Mr. Steve Malizia, Town Administrator
Town of Hudson
12 School St.
Hudson NH 03051

Dear Mr. Malizia,

Hudson Memorial Post 5791 and Auxiliary will be hosting its annual Loyalty Day/Scholastic Awards ceremony on Friday, May 6, 2022 at 7pm. We plan to honor citizens, students, educators, public servants and others who have made significant contributions to the well being of our community. On behalf of our Commander and Auxiliary President, I ask that you nominate a town employee (except fire and police) to be recognized on this date. I have sent an invitation to the Fire and Police Chiefs to recognize members of their departments separately.

You may use any method you would like to choose your nominee. In order to allow sufficient time to prepare the awards and invite the recipients I ask that I have your nomination no later than March 25th. If you have any questions feel free to contact me at (603) 229-7319 or rje7@hotmail.com.

Sincerely,

A handwritten signature in black ink, appearing to read "R. J. Everett", is written over a horizontal line.

Robert J. Everett, Past President, Auxiliary 5791

NO ONE DOES MORE FOR VETERANS.

**VFW POST 5791
PAST LOYALTY DAY RECEIPIENTS**

2021

Mike Johnson & Jacquie Lemay

2020

Chrissy Peterson

2019

Cheryl Chartier

2018

Wayne Madeiros

2017

Jay Twardosky

2016

Helen Cheyne

2015

Lisa Labrie

2014

Danny Arsenault

2013

Donna Staffier-Sommers

2012

Kathy Wilson

2011

Elizabeth Holt

2010

Susan Kaempf

2009

Jennifer Riel

2008

William Oleksak

2007

Priscilla Zakos

2006

Kathleen Voisine

2005

Joseph Anger

2004

Richard Melanson

2003

Gary Webster

Algebra
3.22.22

8M

Town of Hudson

Revenues and Expenditures

Through February 28, 2022

MAR 10 2022

TOWN OF HUDSON
SELECTMEN OFFICE

Town of Hudson, NH
Appropriations and Revenue Summary
Month Ending: February 28, 2022

State #	Dept #	Department	Budget FY 2022	Prior Year Encumbered	Budget and PY Adjstmts	Available Appropriation	Expended To Date	Encumbered	Balance Available	% Expended
01	General Fund									
4199	5020	Trustees of Trust Funds	2,875	0	0	2,875	1,582	0	1,293	55%
4195	5025	Cemetery Trustees	1,250	0	0	1,250	7	0	1,243	1%
4140	5030	Town Clerk/Tax Collector	410,019	0	0	410,019	248,190	4,476	157,352	62%
4140	5041	Moderator	15,059	0	0	15,059	532	1,500	13,027	13%
4140	5042	Supervisors of The Checklist	8,786	0	0	8,786	4,047	0	4,739	46%
4199	5050	Town Treasurer	8,074	0	0	8,074	5,382	0	2,692	67%
4199	5055	Sustainability Committee	1,300	0	0	1,300	118	0	1,182	9%
4520	5063	Benson Park Committee	1,100	0	0	1,100	76	0	1,024	7%
4199	5070	Municipal Budget Committee	800	0	0	800	0	0	800	0%
4140	5077	IT - Town Officers	4,170	0	0	4,170	1,423	1,218	1,529	63%
4199	5080	Ethics Committee	100	0	0	100	11	0	89	11%
		Town Officers	453,533	0	0	453,533	261,369	7,194	184,970	59%
4130	5110	Board of Selectmen/Administra	391,769	0	20,000	411,769	265,641	20,051	126,078	69%
4194	5115	Oakwood	2,275	0	0	2,275	2,720	400	(845)	137%
4194	5120	Town Hall Operations	97,324	0	0	97,324	66,196	500	30,628	69%
4442	5151	Town Poor	80,000	0	0	80,000	19,414	0	60,586	24%
4130	5177	IT - Town Administration	800	0	0	800	1,434	0	(634)	179%
		Administration	572,168	0	20,000	592,168	355,405	20,951	215,812	64%
4153	5200	Legal	136,560	0	0	136,560	86,051	32,977	17,532	87%
4150	5310	Finance Administration	204,957	4,000	0	208,957	113,667	1,693	93,597	55%
4150	5320	Accounting	304,123	3,573	(45)	307,650	197,376	1,262	109,013	65%
4150	5377	IT - Finance	2,250	0	0	2,250	571	79	1,600	29%
		Finance	511,330	7,573	(45)	518,857	311,614	3,034	204,210	61%
4150	5330	Information Technology	742,103	4,555	0	746,658	501,332	3,355	241,971	68%
		Information Technology	742,103	4,555	0	746,658	501,332	3,355	241,971	68%
4152	5410	Assessing Department	469,428	43,826	149,000	662,254	346,868	182,085	133,301	80%
4152	5477	IT- Assessing	14,650	2,431	0	17,081	2,679	35	14,366	16%
		Assessing	484,078	46,257	149,000	679,335	349,547	182,120	147,668	78%
4312	5515	Public Works Facility	59,903	0	0	59,903	60,070	1,539	(1,707)	103%
4312	5551	Public Works Administration	290,872	0	0	290,872	209,400	313	81,160	72%
4312	5552	Streets	2,980,123	0	199,602	3,179,725	2,525,358	104,060	550,307	83%
4312	5553	Equipment Maintenance	498,793	0	0	498,793	295,420	47,512	155,861	69%
4312	5554	Drainage	685,775	0	0	685,775	332,553	2,426	350,796	49%
4522	5556	Parks Division	254,254	0	500	254,754	119,581	4,830	130,344	49%
4312	5577	IT - Public Works	4,290	0	0	4,290	4,026	0	264	94%
		Public Works	4,774,010	0	200,102	4,974,112	3,546,407	160,680	1,267,025	75%

Town of Hudson, NH
Appropriations and Revenue Summary
Month Ending: February 28, 2022

State #	Dept #	Department	Budget FY 2022	Prior Year Encumbered	Budget and FY Adjutmts	Available Appropriation	Expended To Date	Encumbered	Balance Available	% Expended
4191	5277	IT - LUD	6,300	0	0	6,300	3,359	2,528	413	93%
4191	5571	LUD - Planning	258,020	18,488	0	276,508	178,567	9,753	88,188	68%
4191	5572	LUD - Planning Board	8,350	2,311	0	10,661	1,972	1,389	7,300	32%
4191	5581	LUD - Zoning	215,721	0	0	215,721	136,969	1,883	76,869	64%
4191	5583	LUD - Zoning Board of Adj	16,500	0	0	16,500	10,607	4,246	1,647	90%
4311	5585	LUD - Engineering	415,589	796	0	416,385	253,512	15,679	147,194	65%
		Land Use	920,480	21,595	0	942,075	584,987	35,478	321,610	66%
4210	5610	Police Administration	351,939	0	0	351,939	273,734	27,068	51,138	85%
4210	5615	Police Facility Operations	287,854	0	0	287,854	194,169	1,424	92,261	68%
4210	5620	Police Communications	800,766	0	179	800,945	545,015	580	255,350	68%
4210	5630	Police Patrol	7,089,062	25,004	(110)	7,113,956	4,610,949	72,764	2,430,242	66%
4210	5640	Investigations	14,420	0	4	14,424	8,745	1,230	4,449	69%
4414	5650	Animal Control	130,089	0	0	130,089	82,867	1,285	45,938	65%
4210	5660	Information Services	187,189	0	0	187,189	120,855	14	66,320	65%
4210	5671	Support Services	88,023	0	1,893	89,916	38,896	13,154	37,866	58%
4210	5672	Crossing Guards	58,755	0	0	58,755	26,946	0	31,809	46%
4210	5673	Prosecutor	364,372	0	0	364,372	192,938	825	170,609	53%
4210	5677	IT - Police	93,629	0	0	93,629	76,201	3,873	13,555	86%
		Police	9,466,098	25,004	1,966	9,493,068	6,171,314	122,216	3,199,538	66%
4220	5710	Fire Administration	772,075	0	(45)	772,030	503,512	14,257	254,261	67%
4220	5715	Fire Facilities	142,009	5,000	0	147,009	83,763	5,445	57,801	61%
4220	5720	Fire Communications	428,054	0	166	428,220	266,054	6,890	155,276	64%
4220	5730	Fire Suppression	5,894,216	156,797	296,587	6,347,600	4,253,464	54,304	2,039,832	68%
4220	5740	Fire Inspectional Services	501,925	0	364	502,289	299,906	1,533	200,851	60%
4220	5765	Fire Alarm	3,746	0	0	3,746	7	0	3,739	0%
4220	5770	Emergency Management	86,368	22,000	0	108,368	7,527	24,519	76,322	30%
4220	5777	IT - Fire	36,506	0	0	36,506	23,472	1,016	12,017	67%
		Fire	7,864,899	183,797	297,071	8,345,767	5,437,706	107,964	2,800,097	66%
4520	5810	Recreation Administration	178,081	0	0	178,081	84,329	1,451	92,301	48%
4520	5814	Recreation Facilities	66,122	0	0	66,122	39,868	7,794	18,460	72%
4520	5821	Supervised Play	120,063	0	0	120,063	553	169	119,341	1%
4520	5824	Ballfields	12,242	0	0	12,242	2,730	0	9,512	22%
4520	5825	Tennis	0	0	0	0	1,720	0	(1,720)	100%
4520	5826	Lacrosse	12,366	0	0	12,366	0	0	12,366	0%
4520	5831	Basketball	52,604	0	0	52,604	19,507	1,971	31,126	41%
4520	5834	Soccer	13,314	0	0	13,314	12,258	260	796	94%
4520	5835	Senior Activities Operations	62,629	0	0	62,629	20,398	963	41,268	34%
4520	5836	Teen Dances	1,500	0	0	1,500	0	0	1,500	0%
4520	5839	Community Activities	7,060	0	0	7,060	1,155	0	5,905	16%
4520	5877	IT - Recreation	7,065	0	0	7,065	5,793	0	1,272	82%
		Recreation	533,046	0	0	533,046	188,311	12,607	332,128	38%

Town of Hudson, NH
Appropriations and Revenue Summary
Month Ending: February 28, 2022

State #	Dept #	Department	Budget FY 2022	Prior Year Encumbered	Budget and PY Adjmts	Available Appropriation	Expended To Date	Encumbered	Balance Available	% Expended
4196	5910	Insurance	541,000	0	0	541,000	396,250	0	144,750	73%
4199	5920	Community Grants	90,484	0	0	90,484	84,484	0	6,000	93%
4583	5930	Patriotic Purposes	5,600	0	0	5,600	4,100	0	1,500	73%
4199	5940	Other Expenses	161,569	0	(87,207)	74,362	17,569	637	56,156	24%
4220	5960	Hydrant Rental	276,971	0	0	276,971	161,566	0	115,405	58%
4321	5970	Solid Waste Contract	1,710,384	0	0	1,710,384	1,028,492	683,363	(1,470)	100%
		Non-Departmental	2,786,008	0	(87,207)	2,698,801	1,692,460	684,000	322,341	88%
General Fund Appropriation Subtotal			29,244,313	288,780	580,887	30,113,979	19,486,503	1,372,575	9,254,902	69.3%
Warrant Articles										
4194	6012	Major Repairs to Town Bidings	50,000	0	0	50,000	50,000	0	0	100%
4901	6015	Widening Lowell Rd from Was	0	1,345,283	0	1,345,283	22,648	1,322,635	0	100%
4152	6040	Future Prop. Revaluation CRF	15,000	0	0	15,000	15,000	0	0	100%
4220	6057	Fire Apparat Refub & Repr CR	25,000	0	0	25,000	25,000	0	0	100%
4210	6073	Estab. Police Safety Equipment	50,000	0	0	50,000	50,000	0	0	0%
4326	6095	Vaccon Truck Cap Rsrv Fund	30,000	0	0	30,000	30,000	0	0	100%
4909	6099	Town Wide Paving	200,000	0	(200,000)	0	0	0	0	0%
4550	6100	Hills Memorial Library CRF	25,000	0	0	25,000	25,000	0	0	100%
4902	6200	Fire Squad Vehicle	0	119,096	0	119,096	119,096	0	0	100%
4915	6201	Commun Equip & Infrast CRF	0	725,400	0	725,400	542,750	182,650	0	100%
4909	6212	Taylor Falls & Veteran Bridge	0	61,824	0	61,824	15,657	12,044	34,124	45%
0000	6434	Operating Transfer to Library	0	0	0	0	235,985	0	(235,985)	100%
0000	6436	Operating Transfer to Cons Co.	0	0	0	0	0	0	0	100%
General Fund Warrant Articles			395,000	2,251,603	(200,000)	2,446,603	1,131,135.61	1,517,328	(201,861)	108%
General Fund Total Budget			29,639,313	2,540,382	380,887	32,560,582	20,617,638	2,889,903	9,053,040	72%
02 Sewer Fund										
4326	5561	Sewer Billing & Collection	165,643	0	0	165,643	120,685	13,445	31,513	81%
4326	5562	Sewer Operation & Maintenance	1,207,182	0	0	1,207,182	690,977	185,824	330,381	73%
4326	5564	Sewer Capital Projects	870,000	5,639	0	875,639	452,784	234,077	188,778	78%
4326	6086	Vaccon Truck Purchase	400,000	0	0	400,000	391,960	0	8,040	98%
4326	6095	Vaccon Truck Cap Rsrv Fund	30,000	0	0	30,000	30,000	0	0	100%
Sewer Fund			2,672,825	5,639	0	2,678,464	1,686,406	433,346	558,713	79%
03 Water Fund										
4332	5591	Water - Administration	299,122	0	0	299,122	206,241	17,987	74,894	75%
4332	5592	Water - Ops & Maintenance	1,529,042	0	0	1,529,042	919,621	321,828	287,594	81%
4335	5593	Water - Supply	794,174	0	0	794,174	844,629	155,643	(206,098)	126%
4332	5594	Water - Debt Service	1,249,656	0	0	1,249,656	1,249,656	0	1	100%
Water Fund			3,871,994	0	0	3,871,994	3,220,146	495,457	156,391	96%
Total General, Sewer, Water Funds			36,184,132	2,546,022	380,887	39,111,040	25,524,191	3,818,706	9,768,143	75%

Town of Hudson, NH
Appropriations and Revenue Summary
Month Ending: February 28, 2022

State #	Dept #	Department	Budget FY 2022	Prior Year Encumbered	Budget and PY Adjustmts	Available Appropriation	Expended To Date	Encumbered	Balance Available	% Expended
			Budgeted Revenue		Supplemental Budget	Adjusted Revenue	Revenues	Use of Fund Balance	Balance	
		General Fund Revenue	32,648,421		232,940	32,881,361	27,897,713	0	4,983,648	85%
		Sewer Fund Revenue	2,272,825		19,366	2,292,191	1,192,273	0	1,099,919	52%
		Water Fund Revenue	3,871,994		0	3,871,994	2,444,687	0	1,427,307	63%
Total General, Sewer, Water Funds Revenue			38,793,240	0	252,307	39,045,547	31,534,673	0	7,510,873	81%
Other Funds										
State #	Dept #	Department	Budget FY 2022	Prior Year Encumbered	Budget and PY Adjustmts	Available Appropriation	Expended To Date	Encumbered	Balance Available	% Expended
04	5060	Library	1,182,077	0	0	1,182,077	681,519	1,372	499,186	58%
05	5598	Land Use Change Tax Fund	0	0	0	0	0	0	0	100%
06	5586	Conservation Commission	52,753	12,830	0	65,583	38,600	74,360	(47,377)	172%
14	5630	Police Forfeiture Fund	0	0	0	0	607	0	(607)	0%
35	5845	Senior Activities Revolving Fund	0	51,244	0	51,244	4,621	51,244	(4,621)	109%
45	5045	Community TV Revolving Fund	0	4,954	0	4,954	202,713	959	(198,719)	100%
50	5750	EMS Revolving Fund	422,997	0	460	423,457	243,027	24,485	155,945	63%
		Other Funds	1,657,827	69,028	460	1,727,315	1,171,087	152,420	403,807	77%
		(ARPA)								
State #	Dept #	Department	Budget FY 2022	Prior Year Encumbered	Budget and PY Adjustmts	Available Appropriation	Expended To Date	Encumbered	Balance Available	% Expended
44	7200	Flagstone Drainage Infrac.	0	0	0	300,000	218	248,650	51,132	0%
44	7201	Lowell Rd Bridge/Rd Infrac.	0	0	0	700,000	5,049	24,131	670,820	0%
44	7203	West Rd Trns Stn Infrac.	0	0	0	550,000	218	0	549,782	0%
			0	0	0	1,550,000	5,484	272,781	1,271,735	0%
			Budgeted Revenue		Supplemental Budget	Adjusted Revenue	Revenues	Use of Fund Balance	Balance	
		Senior Activities Revolving Fund	0			0	11,394		(11,394)	0%
		Community TV Revolving Fund	0			0	230,256		(230,256)	0%
		EMS Revolving Fund	423,322			423,322	294,407		128,915	0%
Total Expenditures All Funds			37,841,959	2,615,050	381,346	40,838,355	26,695,278	3,971,127	10,171,951	75%

Run: 3/10/22
9:19AM

Revenue Report
Month End Revenue
Town of Hudson, NH
As Of: February 2022, GL Year 2022

Page: 1
bmckee
ReportSortedRevenue
All

2400

Account Number		Est Rev	MTD Rev	YTD Rev	Balance	%Coll
General Fund						
01-0000-4913-000-000	Transfer from Land Use Change Fund	0.00	0.00	0.00	0.00	0.000
01-0000-4914-000-000	Library Revenue	9,675.00	0.00	0.00	9,675.00	0.000
01-3110-4100-000-000	General Property Taxes	21,316,634.00	0.00	20,283,341.26	1,033,292.74	95.153
01-3110-4101-000-000	Overlay	-159,153.00	0.00	-12,631.40	-146,521.60	7.937
01-3185-4120-000-000	Yield Taxes and Interest	10,600.00	0.00	12,896.38	-2,296.38	121.664
01-3186-4115-000-000	In Lieu of Taxes	13,516.00	0.00	0.00	13,516.00	0.000
01-3189-4121-000-000	Excavation Activity Tax	3,000.00	0.00	0.00	3,000.00	0.000
01-3189-4127-000-000	Boat Tax	7,000.00	173.16	2,284.76	4,715.24	32.639
01-3190-4203-000-000	Charges on Property Taxes	5,000.00	87.53	1,915.05	3,084.95	38.301
01-3190-4204-000-000	Interest on Property Taxes	155,000.00	15,529.40	60,721.77	94,278.23	39.175
01-3220-4201-000-000	Motor Vehicle Permits	5,420,000.00	513,594.00	3,792,777.00	1,627,223.00	69.977
01-3230-4216-000-000	Certificate of Occupancy Permit	15,000.00	1,200.00	8,500.00	6,500.00	56.667
01-3230-4218-000-000	Building Permits	275,000.00	13,580.50	160,567.25	114,432.75	58.388
01-3230-4381-000-000	Septic Inspection Fees	6,000.00	600.00	4,100.00	1,900.00	68.333
01-3290-4209-000-000	Excavation Permits	5,000.00	0.00	3,600.00	1,400.00	72.000
01-3290-4214-000-000	Driveway Permits	2,000.00	100.00	2,350.00	-350.00	117.500
01-3290-4217-000-000	Health Permits	0.00	100.00	230.00	-230.00	0.000
01-3290-4221-000-000	Pistol Permits	2,500.00	210.00	966.00	1,534.00	38.640
01-3290-4233-000-000	Oil Burner/Kerosene Permits	0.00	0.00	0.00	0.00	0.000
01-3290-4238-000-000	Police Alarm Permit	2,800.00	105.00	1,025.00	1,775.00	36.607
01-3290-4239-000-000	Fire - Place of Assembly	2,000.00	40.00	1,010.00	990.00	50.500
01-3290-4254-000-000	Fire Alarm Permits	1,500.00	15.00	2,101.00	-601.00	140.067
01-3290-4312-000-000	Zoning Application Fees	3,000.00	222.54	5,514.98	-2,514.98	183.833
01-3290-4313-000-000	Planning Board Fees	120,000.00	7,818.41	76,742.64	43,257.36	63.952
01-3290-4315-000-000	Sewer Service Permit	3,000.00	100.00	2,150.00	850.00	71.667
01-3290-4321-000-000	UCC Filings	7,000.00	1,635.00	5,730.00	1,270.00	81.857
01-3290-4322-000-000	Vital Statistics	10,000.00	1,088.00	11,252.00	-1,252.00	112.520
01-3290-4323-000-000	Police Fines, Forfeit, Court	0.00	0.00	456.25	-456.25	0.000
01-3290-4325-000-000	Animal Control Fines/Fees	10,000.00	0.00	11,188.46	-1,188.46	111.885
01-3290-4326-000-000	Notary Fees	100.00	0.00	0.00	100.00	0.000

Run: 3/10/22
9:19AM

Revenue Report
Month End Revenue
Town of Hudson, NH
As Of: February 2022, GL Year 2022

Page: 2
bmckee
ReportSortedRevenue
All

Account Number		Est Rev	MTD Rev	YTD Rev	Balance	%Coll
01-3290-4327-000-000	Parking Violation Fees	2,000.00	360.00	565.00	1,435.00	28.250
01-3290-4328-000-000	Street Acceptance/Opening Fee	0.00	0.00	0.00	0.00	0.000
01-3290-4334-000-000	Construction Inspection Fee	15,000.00	0.00	30,999.36	-15,999.36	206.662
01-3290-4335-000-000	Animal Boarding Fees	1,100.00	15.00	165.00	935.00	15.000
01-3290-4343-000-000	Copy Fees and Sale of Books	1,500.00	2.00	135.25	1,364.75	9.017
01-3290-4347-000-000	Bad Check Fees	2,500.00	100.00	1,430.47	1,069.53	57.219
01-3290-4356-000-000	Police False Alarm Fines	10,000.00	850.00	4,000.00	6,000.00	40.000
01-3290-4421-000-000	Marriage Licenses	4,000.00	71.00	-112.00	4,112.00	-2.800
01-3290-4422-000-000	Hawker/Peddler License	1,000.00	200.00	500.00	500.00	50.000
01-3290-4427-000-000	Articles of Agreement	0.00	0.00	0.00	0.00	0.000
01-3290-4428-000-000	Pole Licenses	0.00	0.00	0.00	0.00	0.000
01-3290-4430-000-000	Scrap Metal License	0.00	0.00	0.00	0.00	0.000
01-3290-4450-000-000	Animal Control Licenses	18,000.00	847.50	5,833.50	12,166.50	32.408
01-3290-4451-000-000	Drain Layers License	1,000.00	1,500.00	4,000.00	-3,000.00	400.000
01-3351-4840-000-000	Shared Revenue - Municipal Aid	0.00	0.00	0.00	0.00	0.000
01-3352-4841-000-000	Shared Revenue - Meals and Rental Tax Distribution	1,872,194.00	0.00	1,872,194.38	-0.38	100.000
01-3353-4610-000-000	Shared Revenue - Highway Block Grant	537,274.00	0.00	429,819.09	107,454.91	80.000
01-3359-4656-000-000	Grants - Police	26,000.00	5,066.13	31,084.11	-5,084.11	119.554
01-3359-4657-000-000	Grants - Fire	712,278.69	0.00	310,882.48	401,396.21	43.646
01-3359-4659-000-000	Grants - Other	10,000.00	16,104.80	49,494.56	-39,494.56	494.946
01-3359-4660-000-000	Grants - Pandemic	59,955.00	0.00	57,231.92	2,723.08	95.458
01-3379-4300-000-000	Sewer Utility Admin Fee	44,000.00	0.00	44,000.00	0.00	100.000
01-3379-4301-000-000	Water Utility Admin Fee	66,000.00	0.00	66,000.00	0.00	100.000
01-3401-4324-000-000	Police Record Fees	7,000.00	832.00	5,492.00	1,508.00	78.457
01-3401-4342-000-000	Sale of Checklists	500.00	0.00	25.00	475.00	5.000
01-3401-4708-000-000	Welfare Reimbursement	1,000.00	29.65	240.50	759.50	24.050
01-3401-4716-000-000	Cash Over/Short	0.00	0.00	29.87	-29.87	0.000
01-3401-4720-000-000	Police Outside Detail	150,000.00	6,362.04	115,812.03	34,187.97	77.208
01-3401-4729-000-000	Contracted Services - Litchfield	30,000.00	0.00	21,404.76	8,595.24	71.349
01-3401-4730-000-000	Ambulance Billings	422,000.00	0.00	345,718.04	76,281.96	81.924
01-3401-4731-000-000	Charges on Ambulance Receivables	-22,000.00	0.00	-68,374.46	46,374.46	310.793

Run: 3/10/22
9:19AM

Revenue Report
Month End Revenue
Town of Hudson, NH
As Of: February 2022, GL Year 2022

Page: 3
bmckee
ReportSortedRevenue
All

Account Number		Est Rev	MTD Rev	YTD Rev	Balance	%Coll
01-3401-4732-000-000	Fire Incident Reports	500.00	99.00	492.00	8.00	98.400
01-3401-4745-000-000	Cable Franchise Fees	77,000.00	19,260.76	57,564.03	19,435.97	74.758
01-3401-4746-000-000	Police Testing and Application Fees	0.00	0.00	320.00	-320.00	0.000
01-3401-4748-000-000	Insurance Reimbursement	90,000.00	0.00	16,137.44	73,862.56	17.930
01-3401-4756-000-000	Misc Rev - Police	500.00	0.00	1,910.70	-1,410.70	382.140
01-3401-4757-000-000	Misc Rev - Fire	500.00	0.00	320.00	180.00	64.000
01-3401-4758-000-000	Misc Rev - Recreation	0.00	0.00	0.00	0.00	0.000
01-3401-4759-000-000	Misc Rev - Other	500.00	34.04	1,886.34	-1,386.34	377.268
01-3401-4761-000-000	Rec Rev - Basketball	38,720.00	150.00	665.00	38,055.00	1.717
01-3401-4762-000-000	Rec Rev - Supervised Play	141,825.00	0.00	0.00	141,825.00	0.000
01-3401-4764-000-000	Rec Rev - Soccer	20,000.00	0.00	-475.00	20,475.00	-2.375
01-3401-4765-000-000	Rec Rev - Tennis	4,950.00	0.00	-225.00	5,175.00	-4.545
01-3401-4766-000-000	Rec Rev - Teen Dances	4,400.00	0.00	0.00	4,400.00	0.000
01-3401-4767-000-000	Rec Rev - Adult Softball	8,840.00	0.00	1,000.00	7,840.00	11.312
01-3401-4768-000-000	Rec Rev - Lacrosse	7,500.00	0.00	0.00	7,500.00	0.000
01-3401-4769-000-000	Rec Rev - Community Activities	11,000.00	0.00	0.00	11,000.00	0.000
01-3501-4704-000-000	Sale of Town Property	55,000.00	0.00	43,030.08	11,969.92	78.237
01-3502-4702-000-000	Bank Charges	-10,000.00	-530.00	-6,363.30	-3,636.70	63.633
01-3502-4703-000-000	Interest on Investments	20,000.00	86.48	1,296.68	18,703.32	6.483
01-3503-4373-000-000	Rents of Town Property	1,000.00	0.00	1,200.00	-200.00	120.000
01-3508-4556-000-000	Donations - Police	7,366.73	0.00	5,345.00	2,021.73	72.556
01-3508-4557-000-000	Donations - Fire	9,050.00	0.00	5,050.00	4,000.00	55.801
01-3508-4558-000-000	Donations - Recreation	0.00	0.00	0.00	0.00	0.000
01-3508-4559-000-000	Donations - Other	500.00	0.00	1,200.00	-700.00	240.000
01-3914-4996-000-000	Voted from Surplus	0.00	0.00	0.00	0.00	0.000
01-3915-4922-000-000	From Capital Reserve Fund	549,000.00	0.00	0.00	549,000.00	0.000
01-3939-4999-000-000	Use of Fund Balance	600,000.00	0.00	0.00	600,000.00	0.000
Totals	General Fund	32,856,625.42	607,638.94	27,897,713.23	4,958,912.19	84.907

Revenue Report
Month End Revenue
Town of Hudson, NH
As Of: February 2022, GL Year 2022

Account Number		Est Rev	MTD Rev	YTD Rev	Balance	%Coll
Sewer Fund						
02-3190-4180-000-000	Interest on Sewer Utility	20,000.00	46.37	11,226.75	8,773.25	56.134
02-3190-4181-000-000	Sewer Betterment Interest	728.00	0.00	0.00	728.00	0.000
02-3401-4716-000-000	Cash Over/Short	0.00	0.00	0.00	0.00	0.000
02-3403-4780-000-000	Sewer Base Charges	560,000.00	0.00	420,904.39	139,095.61	75.161
02-3403-4781-000-000	Sewer Consumption Charges	581,086.00	0.00	427,715.63	153,370.37	73.606
02-3409-4783-000-000	Sewer Capital Assessment Other Chg	100.00	0.00	0.00	100.00	0.000
02-3500-4773-000-000	Otarnic Pond Betterment Assessment	24,911.00	0.00	24,911.00	0.00	100.000
02-3500-4782-000-000	Sewer Capital Assessment	50,000.00	79,883.90	239,845.20	-189,845.20	479.690
02-3502-4702-000-000	Bank Charges	-3,000.00	0.00	-2,330.35	-669.65	77.678
02-3508-4561-000-000	Donations - Sewer	19,366.26	70,000.00	70,000.00	-50,633.74	361.453
02-3509-4786-000-000	Sewer - Other Income/(Expenses)	0.00	0.00	0.00	0.00	0.000
02-3915-4922-000-000	From Capital Reserve Fund	870,000.00	0.00	0.00	870,000.00	0.000
02-3939-4999-000-000	Use of Fund Balance	124,000.00	0.00	0.00	124,000.00	0.000
02-4915-4915-000-000	To Capital Reserve Fund - Sewer	45,000.00	0.00	0.00	45,000.00	0.000
Totals	Sewer Fund	2,292,191.26	149,930.27	1,192,272.62	1,099,918.64	52.015

Revenue Report
Month End Revenue
Town of Hudson, NH
As Of: February 2022, GL Year 2022

Account Number		Est Rev	MTD Rev	YTD Rev	Balance	%Coll
Water Fund						
03-3190-4794-000-000	Interest on Delinquent Accounts	10,000.00	0.00	2,456.80	7,543.20	24.568
03-3290-4394-000-000	Backflow Testing Fees	25,000.00	95.00	16,055.00	8,945.00	64.220
03-3290-4395-000-000	Water Hookup Fee	25,000.00	100.00	19,481.08	5,518.92	77.924
03-3290-4396-000-000	Water Service Fees	12,000.00	1,765.00	9,541.38	2,458.62	79.512
03-3290-4397-000-000	Shutoff/Reconnect Fee	8,500.00	0.00	2,000.00	6,500.00	23.529
03-3401-4716-000-000	Cash Over/Short	0.00	0.00	0.00	0.00	0.000
03-3401-4748-000-000	Insurance Reimbursement	0.00	0.00	0.00	0.00	0.000
03-3402-4390-000-000	Rental Fee - Private Hydrant	64,000.00	5,356.47	42,851.76	21,148.24	66.956
03-3402-4391-000-000	Rental Fee - Public Hydrant	78,000.00	6,496.20	51,969.60	26,030.40	66.628
03-3402-4392-000-000	Public Fire Protection	224,000.00	19,097.94	152,783.52	71,216.48	68.207
03-3402-4790-000-000	Water Base Charges	960,000.00	80,339.85	646,183.06	313,816.94	67.311
03-3402-4791-000-000	Water Usage Charges	2,173,994.00	136,379.10	1,362,816.92	811,177.08	62.687
03-3402-4792-000-000	Fire Access Charges	204,000.00	16,584.67	132,677.36	71,322.64	65.038
03-3402-4799-000-000	Water Sales to Pennichuck	80,000.00	0.00	6,808.22	73,191.78	8.510
03-3502-4702-000-000	Bank Charges	-2,500.00	0.00	-2,612.32	112.32	104.493
03-3509-4793-000-000	Other Income - Water	10,000.00	375.00	1,675.00	8,325.00	16.750
03-3915-4922-000-000	From Capital Reserve Fund	0.00	0.00	0.00	0.00	0.000
Totals	Water Fund	3,871,994.00	266,589.23	2,444,687.38	1,427,306.62	63.138

Run: 3/10/22
9:19AM

Revenue Report
Month End Revenue
Town of Hudson, NH
As Of: February 2022, GL Year 2022

Page: 6
bmckee
ReportSortedRevenue
All

Account Number		Est Rev	MTD Rev	YTD Rev	Balance	%Coll
Sr Activities Revolving Fund						
35-3401-4735-000-000	Misc Rev - Senior Activities	0.00	1,050.00	7,504.00	-7,504.00	0.000
35-3401-4736-000-000	Membership Fees	0.00	100.00	3,890.00	-3,890.00	0.000
Totals	Sr Activities Revolving Fund	0.00	1,150.00	11,394.00	-11,394.00	0.000

Run: 3/10/22
9:19AM

Revenue Report
Month End Revenue
Town of Hudson, NH
As Of: February 2022, GL Year 2022

Page: 7
bmckee
ReportSortedRevenue
All

Account Number		Est Rev	MTD Rev	YTD Rev	Balance	%Coll
	Community TV Revolving Fund					
45-3401-4745-000-000	Cable Franchise Fees	0.00	77,043.07	230,256.17	-230,256.17	0.000
Totals	Community TV Revolving Fund	0.00	77,043.07	230,256.17	-230,256.17	0.000

Run: 3/10/22
9:19AM

Revenue Report
Month End Revenue
Town of Hudson, NH
As Of: February 2022, GL Year 2022

Page: 8
bmckee
ReportSortedRevenue
All

Account Number		Est Rev	MTD Rev	YTD Rev	Balance	%Coll
EMS Revolving Fund						
50-0000-4729-000-000	EMS - Contracted Services	15,000.00	0.00	17,048.77	-2,048.77	113.658
50-0000-4730-000-000	EMS - 50% Ambulance Billings	430,322.00	0.00	291,718.06	138,603.94	67.791
50-0000-4731-000-000	EMS - 50% Charges on Amb Billings	-22,000.00	0.00	-14,359.48	-7,640.52	65.270
Totals	EMS Revolving Fund	423,322.00	0.00	294,407.35	128,914.65	69.547

**TOWN OF HUDSON
AUTOMOBILE REGISTRATION BY MONTH
FISCAL YEARS 2017, 2018, 2019, 2020, 2021, 2022**

	<u>July</u>	<u>August</u>	<u>September</u>	<u>October</u>	<u>November</u>	<u>December</u>	<u>1st half Fiscal Year</u>	<u>January</u>	<u>February</u>	<u>March</u>	<u>April</u>	<u>May</u>	<u>June</u>	<u>2nd half Fiscal Year</u>	<u>Actual Fiscal Year Total</u>	<u>Budget Fiscal Year Total</u>
FY2017	\$327,635	\$400,991	\$435,251	\$400,872	\$390,525	\$422,355	\$2,377,628	\$527,661	\$425,856	\$464,481	\$397,461	\$521,282	\$460,464	\$2,797,204	\$5,174,832	\$4,550,000
vs. Budget	7.2%	16.0%	25.6%	34.4%	43.0%	52.3%	52.3%	63.9%	73.2%	83.4%	92.2%	103.6%	113.7%	61.5%	vs. Budget	113.7%
FY2018	\$345,710	\$427,939	\$416,805	\$443,016	\$371,576	\$453,830	\$2,458,875	\$582,567	\$460,122	\$473,141	\$402,980	\$543,706	\$507,592	\$2,970,108	\$5,428,983	\$4,700,000
vs. Budget	7.4%	16.5%	25.3%	34.8%	42.7%	52.3%	52.3%	64.7%	74.5%	84.6%	93.1%	104.7%	115.5%	63.2%	vs. Budget	115.5%
FY2019	\$429,067	\$457,722	\$389,685	\$464,888	\$471,953	\$454,133	\$2,667,448	\$531,274	\$504,668	\$444,548	\$561,605	\$513,577	\$511,323	\$3,066,993	\$5,734,441	\$5,000,000
vs. Budget	8.6%	17.7%	25.5%	34.8%	44.3%	53.3%	53.3%	64.0%	74.1%	83.0%	94.2%	104.5%	114.7%	61.3%	vs. Budget	114.7%
FY2020	\$437,974	\$485,183	\$410,994	\$530,162	\$446,610	\$470,237	\$2,781,159	\$638,551	\$515,784	\$416,309	\$331,136	\$452,398	\$745,339	\$3,099,517	\$5,880,675	\$5,420,000
vs. Budget	8.1%	17.0%	24.6%	34.4%	42.6%	51.3%	51.3%	63.1%	72.6%	80.3%	86.4%	94.7%	108.5%	57.2%	vs. Budget	108.5%
FY2021	\$516,858	\$430,094	\$461,725	\$494,524	\$440,822	\$489,084	\$2,833,106	\$542,186	\$502,930	\$627,048	\$523,883	\$518,796	\$571,111	\$3,285,953	\$6,119,060	\$5,420,000
vs. Budget	9.5%	17.5%	26.0%	35.1%	43.2%	52.3%	52.3%	62.3%	71.6%	83.1%	92.8%	102.4%	112.9%	60.6%	vs. Budget	112.9%
FY2022	\$433,575	\$488,988	\$450,479	\$504,693	\$429,947	\$435,191	\$2,742,872	\$536,311	\$513,594					\$1,049,905	\$3,792,777	\$5,420,000
vs. Budget	8.0%	17.0%	25.3%	34.6%	42.6%	50.6%	50.6%	60.5%	70.0%					19.4%	vs. Budget	70.0%

**TOWN OF HUDSON
GENERAL FUND INTEREST BY MONTH
FISCAL YEARS 2017, 2018, 2019, 2020, 2021, 2022**

	<u>July</u>	<u>August</u>	<u>September</u>	<u>October</u>	<u>November</u>	<u>December</u>	<u>1st half Fiscal Year</u>	<u>January</u>	<u>February</u>	<u>March</u>	<u>April</u>	<u>May</u>	<u>June</u>	<u>2nd half Fiscal Year</u>	<u>Actual Fiscal Year Total</u>	<u>Budget Fiscal Year Total</u>
FY2017	\$6,112	\$0	\$5,786	\$4,242	\$3,440	\$2,256	\$21,836	\$0	\$5,991	\$9,498	\$16,578	\$6,333	\$7,235	\$45,635	\$67,471	\$19,000
vs. Budget	32.2%	32.2%	62.6%	84.9%	103.1%	114.9%	114.9%	114.9%	146.5%	196.4%	283.7%	317.0%	355.1%	240.2%	vs. Budget	355.1%
FY2018	\$14,877	\$14,656	\$7,236	\$4,331	\$9,647	\$6,947	\$57,694	\$16,560	\$18,741	\$14,208	\$15,488	\$19,596	\$16,919	\$101,512	\$159,206	\$25,000
vs. Budget	59.5%	118.1%	147.1%	164.4%	203.0%	230.8%	230.8%	297.0%	372.0%	428.8%	490.8%	569.1%	636.8%	406.0%	vs. Budget	636.8%
FY2019	\$0	\$45,557	\$38,553	\$27,494	\$0	\$46,686	\$158,289	\$45,246	\$52,094	\$42,049	\$0	\$66,149	\$19,534	\$225,072	\$383,361	\$120,000
vs. Budget	0.0%	38.0%	70.1%	93.0%	93.0%	131.9%	131.9%	169.6%	213.0%	248.1%	248.1%	303.2%	319.5%	187.6%	vs. Budget	319.5%
FY2020	\$0	\$42,580	\$39,013	\$33,695	\$24,052	\$13,649	\$152,989	\$6,066	\$35,128	\$32,541	\$8,141	\$5,937	\$21,179	\$108,992	\$261,981	\$361,000
vs. Budget	0.0%	11.8%	22.6%	31.9%	38.6%	42.4%	42.4%	44.1%	53.8%	62.8%	65.1%	66.7%	72.6%	30.2%	vs. Budget	72.6%
FY2021	\$0	\$0	\$12,143	\$0	\$0	\$3,909	\$16,052	\$0	\$611	\$210	\$204	\$198	\$142	\$1,365	\$17,417	\$261,000
vs. Budget	0.0%	0.0%	4.7%	4.7%	4.7%	6.2%	6.2%	6.2%	6.4%	6.5%	6.5%	6.6%	6.7%	0.5%	vs. Budget	6.7%
FY2022	\$147	\$147	\$195	\$350	\$175	\$102	\$1,115	\$96	\$86					\$182	\$1,297	\$20,000
vs. Budget	0.1%	0.1%	2.4%	4.2%	5.1%	5.6%	5.6%	6.1%	6.5%					0.9%	vs. Budget	6.5%

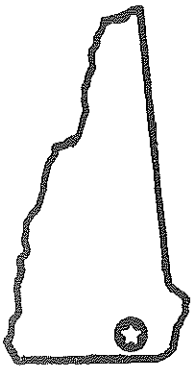

TOWN OF HUDSON
Office of the Town Administrator
12 School Street
Hudson, New Hampshire 03051

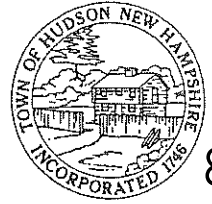

8N

Agenda #
3-22-22

Stephen A. Malizia, Town Administrator – smalizia@hudsonnh.gov – Tel: 603-886-6024 Fax: 603-598-6481

To: Board of Selectmen

From: Steve Malizia, Town Administrator

Date: March 9, 2022

Re: Settlement Agreement – Heidi Jakoby, et al v. Town of Hudson

Attached please find the Settlement Agreement and General Release entered into for the Heidi Jakoby et al v. Town of Hudson matter. Section 4.0 of the agreement discusses an advisory Right to Know Law Committee which the Board of Selectmen will form for the purpose of proposing a policy to the Board for implementing a Right to Know Law operational policy for the Town. The committee will consist of one (1) Town staff member, one (1) member of the Board of Selectmen, two (2) citizen members chosen by the Board from people recommended by the plaintiffs and one (1) member chosen by the committee of four (4) members. The purpose of the Committee will be to draft and recommend an administrative and operational policy for the Board of Selectmen's consideration relative to the Right to Know Law. I am recommending that the Board of Selectmen form the required committee by appointing a Selectmen member, soliciting a volunteer from Town Staff and soliciting a list of people from the plaintiffs for consideration. The following motion is appropriate:

Motion: To form a Right to Know Law Committee and to appoint Selectman _____ to the committee, to solicit an employee (staff) volunteer for the committee and to solicit a list of candidates from the plaintiffs for consideration.

Should you have any questions or need additional information, please feel free to contact me.

SETTLEMENT AGREEMENT AND GENERAL RELEASE

This Settlement Agreement and General Release ("Agreement") is entered into as of the last date on the signature page of this Agreement, by and between Heidi Jakoby, Christopher Thatcher, Jerome Bento, and James Crowley, ("Plaintiffs"), Hillwood Enterprises, LP ("Hillwood"), and the Town of Hudson, by and through its Selectboard, ("The Town"), all collectively referred to as ("the Parties.")

WHEREAS, Plaintiffs commenced an action in the Hillsborough County Superior Court, Southern Judicial District, docketed in said Court as case 226-2021-CV-00161, alleging The Town violated New Hampshire's Right-to-Know law, RSA 91-A (the "Action.")

WHEREAS, the purpose of this Agreement is to resolve fully, finally, and amicably, any and all differences, disputes, and issues between the Parties in said Action.

NOW THEREFORE, in consideration of the agreements, promises, consideration, and covenants set forth herein, the receipt and sufficiency of which is acknowledged, the Parties agree as follows:

- 1.0 Dismissal of Action. The Parties shall file a stipulation with the Court marking the docket as follows: "Judgment for neither party. No interest. No costs. No further action for the same cause. With prejudice." The stipulation will be filed within ten (10) business days after the Effective Date, as defined in the following paragraph.
- 2.0 Effective Date. The Effective Date of this Agreement shall be the last date upon which all Parties have signed this Agreement.
- 3.0 No Liability or Wrongdoing by Town or Plaintiffs. The Parties, for themselves and their respective affiliates, agents, officials, employees, attorneys, heirs, successors, and assigns, do hereby agree that the Town provided the requested records, that no public records were intentionally withheld, and that the Plaintiffs reasonably commenced and pursued the Action in good faith and not in a malicious or frivolous way.
- 4.0 Right to Know Law Advisory Committee
 - 4.1 Committee. The Town of Hudson Selectboard ("The Selectboard") will form a temporary, advisory Right to Know Law committee ("The Right to Know Law Advisory Committee") for the purpose of proposing a policy to the Selectboard for implementing the Right to Know Law in the Town.
 - 4.2 Membership. Membership of The Committee shall be appointed by the Selectboard, comprised, as follows:
 - 4.2.1 One (1) Town staff person to be chosen by the Selectboard within 35 days of the Effective Date;

- 4.2.2 One (1) member of the Selectboard to be chosen by the Selectboard within 35 days of the Effective Date;
- 4.2.3 Two (2) people, also citizens of Hudson, to be chosen by the Selectboard from people recommended by the Plaintiffs within 35 days of the Effective Date; and
- 4.2.4 One (1) citizen of the Town to be chosen by the Committee of the above four members by no later than 10 calendar dates of the last dates chosen from paragraphs 1, 2, and 3 above.

4.3 Purpose. The purpose of the Committee will be to draft and recommend an administrative and operational policy for the Town relative to the Right to Know Law. Any such recommended policy shall be presented to the Selectboard for their consideration, in whole or in part, it being understood that the Selectboard shall determine what constitutes the Town's final policy. The Parties acknowledge that any appropriation arising out of the implementation of any such policy will require the approval of the legislative body of the Town.

4.4 Topics and Concepts. The following topics are worthwhile for the Committee to consider, and therefore the Committee will consider them, though, upon consideration, the Committee may conclude that the policy the Committee will draft will not address any given topic. In other words, by including the topics in the following list, the resultant obligation of the Committee is that they consider the topic, not necessarily that they decide to include it in the resultant policy they will draft. The policy recommended to the Selectboard may include some or all of these topics and concepts, and/or may include topics and concepts not included below.

- Record Archives
- Email Archives
- Privileged Accounts
- Town Email Addresses
- Right-to-Know Officer
- Archive Protocol
- Costs And Budget

4.5 Timing of Production of Drafts. The Committee shall produce drafts of the Policy to be shared with the Selectboard as follows:

- First Draft: Within sixty (60) days of the Effective Date
- Second Draft: Within one hundred and twenty (120) days of the Effective Date;
- Final Draft: Within one hundred and eighty (180) days of the Effective Date.

4.6 Policy. By no later than November 30, 2022, the Selectboard agrees to adopt a written policy for the implementation of the Right to Know law in the Town.

- 5.0 Mutual Releases. The Parties, for themselves and on behalf of their respective affiliates, employees, officers, board members, members, managers, directors, successors, agents, attorneys, representatives, heirs, beneficiaries, trustees, executors, administrators, legatees, devisees, assigns (“Agents”), hereby remise, release and forever discharge one another, and their Agents, from any and all claims, losses, expenses, damages, demands, rights, causes of action, and liability of any kind whatsoever (whether at law or equity, whether asserted or unasserted, whether known or unknown), they have had, or suffered, may now have or suffer, or may hereafter have or suffer, arising, accruing or relating in any way from the Action, from the beginning of the world to the Effective Date, it being the intention of the Parties to “buy peace” for all claims, known and unknown.
- 6.0 Assistance of Counsel. All parties acknowledge and agree they have had the opportunity to consult with counsel of their choice, and they enter into this Agreement freely and voluntarily, with no duress or coercion, and with a full understanding of the ramifications of the terms and conditions of the Agreement.
- 7.0 Nonwaiver. The failure of any Party to insist upon or enforce strict performance by the other Party of any provision of this Agreement, or the failure of any Party to exercise any right or remedy under this Agreement, will not be interpreted or construed as a waiver or relinquishment to any extent of that Party’s right to assert or rely upon any such provision, right or remedy in that or any other instance; rather, the same will be and remain in full force and effect.
- 8.0 Severability. The provisions of this Agreement shall be deemed severable, and the invalidity or unenforceability of any provision shall not affect the validity or the enforceability of the other provisions hereof. If, in any judicial proceedings or arbitration proceeding, a court or arbitrator shall refuse to enforce one or more of the covenants or agreements contained herein because the duration is too long, or the scope thereof is too broad, it is expressly agreed between the parties hereto that such scope or duration shall be reduced to the extent necessary to permit the enforcement of such covenants or agreements.
- 9.0 Counterparts. This Agreement may be executed in any number of counterparts which, when taken together, shall constitute a single binding instrument. Execution and delivery of this Agreement by facsimile or scan shall be sufficient for all purposes and shall be binding on any person who so executes.
- 10.0 Survival. The rights and obligations of the parties under the terms of this Agreement shall survive the expiration or termination of this Agreement.
- 11.0 No Construction Against Drafter: Construction of this Agreement. This Agreement shall not be construed against any party hereto, regardless of which party drafted this Agreement and that any interpretation of the terms or any claimed ambiguities shall not be construed against any party. The parties expressly acknowledge that this Agreement was mutually drafted by the parties and their respective counsel,

- 12.0 Controlling Law. The validity, interpretation, performance, and enforcement of this Agreement shall be governed by the laws of the State of New Hampshire.
- 13.0 Modification. No provision of this Agreement shall be modified, waived, or discharged unless agreed to in a writing signed by all parties.

**Heidi Jakoby, Christopher
Thatcher, Jerome Bento, and
James Crowley**
By their Attorneys:

BCM Environmental & Land Law,
PLLC

Date: 3/1/22

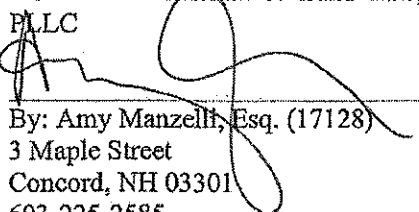
By: Amy Manzelli, Esq. (17128)
3 Maple Street
Concord, NH 03301
603-225-2585
manzelli@nhlandlaw.com

Town of Hudson
By its Attorneys:

Tarbell & Brodich

Date: 3/1/22

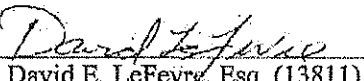

David E. LeFevre, Esq. (13811)
45 Centre Street
Concord, NH 03301
(603) 226-3900
dlefevre@tarbellbrodich.com

Hillwood Enterprises, LP
By its Attorneys:

Donahue, Tucker & Ciandella, PLLC

Date: 3/1/22

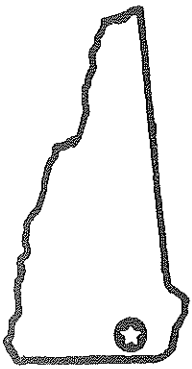

Christopher T. Hilson, Esq. (17116)
16 Acadia Lane, P.O. Box 630
Exeter, NH 03833
603-778-0686
chilson@dtclawyers.com



TOWN OF HUDSON
Office of the Town Administrator
 12 School Street
 Hudson, New Hampshire 03051

Approved

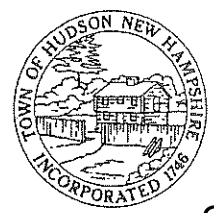
3-22-22



Stephen A. Malizia, Town Administrator – smalizia@hudsonnh.gov – Tel: 603-886-6024 Fax: 603-598-6481

80

To: Board of Selectmen

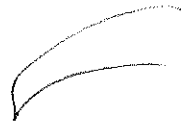
From: Steve Malizia, Town Administrator 

Date: March 11, 2022

Re: Proposal for Legal Services 2022-2023

Attached please find correspondence from Town Attorney David Lefevre offering to continue to serve as general legal counsel for the Town of Hudson for Fiscal Year 2023 (July 1, 2022 to June 30, 2023) for the current rate of \$145.00 per hour. All other terms remain the same as outlined in Attorney Lefevre's letter. Attorney Lefevre has served as the Town's general counsel for the past seven (7) years and has not raised his hourly rate in the seven years he been the Town's general counsel. The Board also has the option of going out to bid for general legal services should the Board choose to do so. Should the Board of Selectmen vote to renew Attorney Lefevre's contract for legal services, the following motion is appropriate:

Motion: To enter into a contract for legal services with the law firm of Tarbell & Brodich, PA for the period of July 1, 2022 through June 30, 2023 for the terms as specified in the Proposal for Legal Services 2022-2023 letter as prepared by Attorney David Lefevre.

Should the Board of Selectmen vote to go out to bid for legal services, the following motion is appropriate:

Motion: To authorize the Town Administrator to request proposals to provide legal services for the Town of Hudson for fiscal year 2023 (July 1, 2022 through June 30, 2023).

Should you have any questions or need additional information, please feel free to contact me.

**TARBELL
& BRODICH, PA**
ATTORNEYS AT LAW

March 11, 2022

RECEIVED

MAR 11 2022

TOWN OF HUDSON
SELECTMEN'S OFFICE

Board of Selectmen
Town of Hudson
12 School Street
Hudson, NH 03051

RE: Proposal for Legal Services 2022-2023

Dear Chair and Members of the Board of Selectmen:

Please accept this letter as our proposal to continue to serve as general legal counsel for the Town of Hudson.

Tarbell & Brodich, P.A. proposes to continue to provide legal services to the Town at the present reduced rate of \$145.00 per hour, which is the same rate for all attorneys, will not vary between litigation and non-litigation services, and will not be increased after a certain number of hours. Non-attorney paralegal time will also be charged at the current reduced rate of \$60.00 per hour. As always, no retainer is requested. Fees for legal services will continue to be billed in increments of 1/10 of an hour and invoiced on a monthly basis.

Routine overhead and expenses will not be billed to the Town. Out-of-pocket expenses such as filing fees, sheriff's service fees, registry recording fees, etc., will be billed to the Town and itemized separately on the monthly invoices, as would other non-typical costs such as excessive postage or copying charges. The Town would not be billed for travel time to and from Town offices or Court.

This proposal would be in effect for a period of one (1) year following the date of acceptance.

I would like to convey to the Selectmen my thanks for being given the opportunity to work for the Town, and I hope to continue to represent the Town in the future.

Sincerely,

TARBELL & BRODICH, P.A.

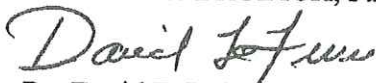

By: David E. LeFevre, Esq.
e-mail: dlefevre@tarbellpa.com

*Eaton W. Tarbell, Jr.
Nicholas Brodich
Caroline K. Brown
Mary A. Hakken-Phillips
David E. LeFevre
Friedrich K. Moeckel*
Shane R. Stewart
Eaton W. Tarbell, III*

*All Attorneys admitted
in New Hampshire
or as otherwise designated.*

**Also admitted in Massachusetts*

*45 Centre Street
Concord, NH 03301*

*1-877-898-1135
603-226-3900 Tel
603-225-5398 Fax*



TOWN OF HUDSON

Board of Selectmen

12 School Street · Hudson, New Hampshire 03051 · Tel: 603-886-6024 · Fax: 603-598-6481



8P

March 17, 2022

To: Board of Selectmen

From: Jill Laffin

Re: Discussion - Budget Committees Vote to Change By-Laws

At their meeting on March 16, 2022, the Budget Committee amended its bylaws to exclude the Board of Selectmen member and the School Board member from voting as members of the Budget Committee. Selectman Gagnon asked that this item be placed on the Board of Selectmen's agenda for discussion.

TITLE III

TOWNS, CITIES, VILLAGE DISTRICTS, AND UNINCORPORATED PLACES

CHAPTER 32

MUNICIPAL BUDGET LAW

Budget Committee

Section 32:15

32:15 Budget Committee Membership. –

I. The budget committee shall consist of:

(a) Three to 12 members-at-large, who may be either elected or appointed by the moderator, as the town or district adopting the provisions of this subdivision shall by vote determine, who shall serve staggered terms of 3 years; and

(b) One member of the governing body of the municipality and, if the municipality is a town, one member of the school board of each school district wholly within the town and one member of each village district wholly within the town, all of whom shall be appointed by their respective boards to serve for a term of one year and until their successors are qualified. Each such member may be represented by an alternate member designated by the respective board, who shall, when sitting, have the same authority as the regular member.

II. If the meeting decides that members-at-large are to be appointed, the staggering of terms shall begin that same year, with 1/3 of such members chosen to hold office for one year, 1/3 for 2 years, and 1/3 for 3 years, and each year thereafter 1/3 shall be chosen for terms of 3 years and until their successors are appointed and qualified. If the number of members-at-large is not divisible by 3, the division shall be as even as possible over the 3 years. All such appointments shall be made within 30 days after the annual meeting.

III. If the meeting decides members-at-large are to be elected, the meeting shall either elect the initial members for one-year terms by means other than by official ballot, or shall authorize the moderator to appoint members to serve until the next annual meeting, as provided in RSA 669:17. Elections for staggered terms, as described in paragraph II, shall not begin until that next annual meeting, and shall be by official ballot if the municipality has adopted the official ballot system, as set forth in RSA 669.

IV. A town or district which has adopted this subdivision may vote at any subsequent annual meeting to change the number or manner of selection of its members-at-large. No such change shall take effect until the annual meeting following the meeting at which the change was adopted.

V. No selectman, town manager, member of the school board, village district commissioner, full-time employee, or part-time department head of the town, school district or village district or other associated agency shall serve as a member-at-large. Every member-at-large shall be domiciled in the town or district adopting this subdivision and shall cease to hold office immediately upon ceasing to be so domiciled.

VI. One of the members-at-large shall be elected by the budget committee as chair. The committee may elect other officers as it sees fit. A member-at-large shall cease to hold office immediately upon missing 4 consecutive scheduled or announced meetings of which that member received reasonable notice, without being excused by the chair.

VII. In municipalities where members-at-large are appointed, the chair shall notify the moderator immediately upon the occurrence of any vacancy in the membership-at-large, and the vacancy shall be filled by appointment by the moderator within 5 days of such notification, otherwise by the budget committee. In

municipalities where members-at-large are elected, vacancies shall be filled by appointment by the budget committee. Persons appointed to fill vacancies shall serve until the next annual meeting at which time a successor shall be elected or appointed to either fill the unexpired term or start a new term, as the case may be.

Source. 1993, 332:1, eff. Aug. 28, 1993. 1998, 141:1, 2, eff. Aug. 7, 1998.



TOWN OF HUDSON
Office of the Town Administrator
12 School Street
Hudson, New Hampshire 03051

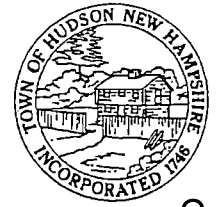

Agenda
3-22-22

Stephen A. Malizia, Town Administrator – smalizia@hudsonnh.gov – Tel: 603-886-6024 Fax: 603-598-6481

8Q

To: Board of Selectmen

From: Steve Malizia, Town Administrator 

Date: March 9, 2022

Re: Nomination and Appointment – Board of Selectmen Chairman and Vice-Chairman

The Board of Selectmen need to nominate and appoint a Chairman and Vice-Chairman for the upcoming year. The following motions are appropriate:

Motion: To nominate Selectman _____ as Chairman of the Board of Selectmen.

Motion: To nominate Selectman _____ as Vice-Chairman of the Board of Selectmen.

Motion: to close the nominations and appoint _____ as Chairman of the Board of Selectmen.

Motion: To close the nominations and appoint _____ as Vice-Chairman of the Board of Selectmen.

Should you have any questions or need additional information, please feel free to contact me. Thank you.