

# **REQUEST FOR PROPOSAL**

---

## **CONSTRUCTION SERVICES FOR FREEDOM FIELD REHABILITATION TOWN OF HUDSON, NH**

**Prepared for**

**Town of Hudson  
Engineering Department  
12 School Street  
Hudson, NH 03051**

**MARCH 2023**



**Prepared by**

**Town of Hudson  
Engineering Department  
12 School Street  
Hudson, NH 03051**



Section	Total # of Pages
TOC	1

**TABLE OF CONTENTS**

RFB	REQUEST FOR PROPOSAL .....	21
NOA	NOTICE OF AWARD .....	2
FA	FORM OF AGREEMENT .....	5
PPB	PERFORMANCE BOND .....	2
PYB	BID BOND .....	2
BS	BID SCHEDULE.....	3
GC	GENERAL CONDITIONS.....	51
PL	PLANS .....	5



## REQUEST FOR PROPOSAL

The Town of Hudson, New Hampshire wishes to engage the services of a qualified private firm to provide construction services for:

### FREEDOM FIELD REHABILITATION

The CONTRACTOR must be lawfully engaged in the service of construction in the State of New Hampshire.

An overview and detailed specifications are provided later in the Request for Proposal (RFP).

Proposals must be received no later than **10:00 AM on May 30, 2023** from interested firms, to be eligible for consideration by the Town. Proposal shall follow the format listed below and be on the forms provided as required. Each statement shall be submitted in a sealed envelope, which is clearly marked,

### **“CONSTRUCTION SERVICES FOR FREEDOM FIELD REHABILITATION HUDSON, NEW HAMPSHIRE”**

Requests may be issued only by the Town Engineer, or his designee, to authorized firms, and are not transferable unless authorized by the Town Engineer or his designee.

Complete copies of RFP are available from:

Mr. Elvis Dhima, P.E.  
Town Engineer  
Town Hall  
12 School Street  
Hudson, NH 03051  
[edhima@Hudsonnh.gov](mailto:edhima@Hudsonnh.gov)

**All proposals received will be considered confidential and not available for public review until after a vendor has been selected.**

The Town reserves the right to reject any or all proposals or any part thereof, to waive any formality, informality, information or errors in the proposal, to accept the proposal considered to be in the best interest of the Town, or to purchase on the open market if it is considered in the best interest of the Town to do so. Failure to submit all information called for and/or submission of an unbalanced proposal are sufficient reasons to declare a proposal as non-responsive and subject to disqualification.

**Proposals which do not incorporate our requested format for providing FREEDOM FIELD REHABILITATION will not be considered.**

All proposals are advertised, at the Town's discretion and are posted publicly as detailed below:

<b>Name</b>	<b>Advertising Medium</b>	<b>Address</b>	<b>Phone/Fax</b>	<b>Email and Web Address</b>
Town Hall Hudson, NH	Post at Town Hall	12 School Street, Hudson NH 03051	603.886.6008 603.594.1142(fax)	<a href="mailto:edhima@hudsonnh.gov">edhima@hudsonnh.gov</a>

TOWN OF HUDSON, NEW HAMPSHIRE

\_\_\_\_\_  
Mr. Elvis Dhima, PE, Town Engineer

Date: \_\_\_\_\_

**PROPOSAL DUE DATE/TIME: MAY 30, 2023 NOT LATER THAN 10:00 AM AT THE TOWN CLERK OFFICES, 12 SCHOOL STREET, HUDSON, NH.**

**A MANDATORY PRE-PROPOSAL MEETING WILL BE HELD AT THE SITE (194 DERRY ROAD) ON MAY 16, 2023 AT 9:00 AM.**

**ALL QUESTIONS DUE BY MAY 23, 2023 AT 10:00 AM.**

**THE FUNDING FOR THIS PROJECT IS PENDING GRANT APPROVAL IN MID MAY 2023.**

PREPARATION OF PROPOSALS:

Proposals shall be submitted on the forms provided and must be signed by the Proposer or the Proposer's authorized representative. The person signing the proposal shall initial any corrections to entries made on the proposal forms.

Proposers must quote on all items appearing on the proposal forms. Failure to quote on all items may disqualify the proposal.

Unless otherwise stated in the Request for Proposal (RFP), the Proposer agrees that the proposal shall be deemed open for acceptance for ninety (90) calendar days subsequent to submittal to the Town of Hudson or as modified by addendum.

Any questions or inquiries must be submitted in writing, and must be received by the Town Engineer, Elvis Dhima ([edhima@hudsonnh.gov](mailto:edhima@hudsonnh.gov)) no later than seven (7) calendar days before the Request for Proposals due date to be considered. Any responses to questions,

clarifications, or changes to the Request for Proposals will be provided to all Proposers of record that attended the mandatory pre-proposal meeting.

The Proposer shall not divulge, discuss or compare this proposal with other Proposers and shall not collude with any other Proposers or parties to a proposal whatever.

#### MANDATORY PRE-BID MEETING:

All Proposers must attend the pre-proposal meeting at the SITE at 10:00 AM on **MAY 16, 2023**. The site is located behind **194 DERRY ROAD**.

#### SUBMISSION OF PROPOSALS:

Proposals must be submitted at the Clerk's Office, Town Hall Offices, 12 School Street, Hudson NH by 10:00AM MAY 30, 2023 as directed in the Request for Proposals, and on the forms provided unless otherwise specified. Proposals must be typewritten or printed in ink. Proposals must be mailed or delivered in person. Proposals that are faxed or e-mailed will not be accepted.

#### PERFORMANCE BOND AND PAYMENT BOND

A Performance Bond and Payment Bond, each in the amount of 100% of the Contract Price, will be required of the successful Proposer (See Attached).

#### BID BOND

Each Bidder shall accompany the proposal with a bid guarantee in the form of Cashier's Check, or a Certified Check payable to the Town of Hudson, or a Bid Bond secured by a guaranteed company or surety company licensed to operate in the State of New Hampshire in the amount of 5% of the Bid. (See Attached).

This bid guarantee shall ensure the execution of a Contract, the furnishing of a Performance Bond, and a Payment Bond, all of which shall remain in effect for ninety (90) days after receipt of Bid by the Owner.

The bid guarantees of the unsuccessful Bidders shall be returned as soon as practicable.

Attorneys-in-fact who sign bid bonds or contract bonds must file with each bond a certified and effectively dated copy of their Power of Attorney.

#### AMENDMENTS TO PROPOSALS

If this solicitation is amended, then all terms and conditions which are not modified remain unchanged.

Proposers shall acknowledge receipt of any amendment to this solicitation (1) by identifying the amendment number and date on the Proposal form, or by letter. Proposals which fail to acknowledge the Proposer's receipt of any amendment will result in the rejection of the Proposal if the amendment(s) contained information which substantively changed the municipality's requirements.

Amendments will be on file in the offices of the municipality and the Engineer at least 1 day before Proposal opening.

#### WITHDRAWAL OF PROPOSALS:

Proposals may be withdrawn by written notice, telegram (including mailgram) or facsimile machine transmission received at any time before the exact time set for opening of proposals; provided that written confirmation of telegraphic or facsimile withdrawals over the signature of the proposer is mailed and postmarked prior to the specified proposal opening time. A proposal may be withdrawn in person by a proposer or its authorized representative if, before the exact time set for opening of proposals, the identity of the person requesting withdrawal is established and the person signs a receipt for the proposal. Negligence on the part of the Proposer in preparing this proposal shall not constitute a right to withdraw a proposal subsequent to the proposal opening. Proposals may not be withdrawn for the period as indicated in this Request for Proposals or as modified by addenda.

#### RECEIPT AND OPENING OF PROPOSALS:

Proposals shall be submitted prior to the time fixed in the Request for Proposals. Proposals received after the time so indicated shall be returned unopened.

All qualified Bidders will receive consideration without regard to race, color, religion, creed, age, sex, or national origin.

#### PROPOSAL RESULTS:

**All proposals received shall be considered confidential and not available for public review until after a contractor has been selected. All proposals may be subject to negotiations prior to the award of a contract.**

**NO TELEPHONE REQUESTS FOR RESULTS WILL BE ACCEPTED OR GIVEN.**

#### TIE PROPOSALS:

When identical Proposals are received, with respect to price, delivery, financial resources, experience, ability to perform and quality, award may be made by a toss of a coin.

#### LIMITATIONS:



This Request for Proposal (RFP) does not commit the Town to award a contract, to pay any costs incurred in the preparation of a response to this request, or to procure or contract for services, supplies or equipment. The Town reserves the right to accept or reject any or all proposals received as a result of this request, or to cancel in part or in its entirety this RFP, if it is in the best interest of the Town to do so.

The OWNER reserves the right to waive any informalities, to negotiate with any Bidder and to reject any or all Bids. No Bidder may withdraw his Bid within ninety (90) days after the actual date of the opening thereof.

#### PROPOSAL EVALUATION:

In an attempt to determine if a Proposer is responsible, the Town, at its discretion, may obtain technical support from outside sources. Each Proposer will agree to fully cooperate with the personnel of such organizations.

#### PROJECT BACKGROUND

The town of Hudson owns a multipurpose athletic field which needs to be modified.

#### SCOPE OF SERVICES

The Town of Hudson Engineering Department is soliciting contractor for construction services for the following:

1. Existing fence removal.
2. Grading the site, which includes multipurpose athletic field.
3. Building multipurpose athletic field using the plans prepared by the Town.
4. Installing a 4-foot fence around the multipurpose athletic field.
5. Installing irrigation system for the multipurpose athletic field.
6. Loam and hydroseed.
7. Follow the Plans provided by the Town

All prices include labor and material.

Proposers shall demonstrate experience in the design and installation of projects.

1. Description of Services Requested

The Contractor will need to provide the Town with a written description of the proposed work for review and approval.

Work will include:

- Construction of a multipurpose athletic field, chain link fence and irrigation system.

## 2. Time Frame for Performance of Services

A contract will be signed as soon as possible after the Proposal due date and completion of the Proposal evaluations, but no later than July 2023. The Contractor will be able to start work as of July 2023-weather dependent and must be substantially complete on or before October 15, 2023.

## CONSTRUCTION BUDGET

Construction budget is \$475,000 and engineer's estimate is below this value.

## TRAFFIC CONTROL/MAINTENANCE

The Town reserves the right to hire Hudson Police Department or Highway Department staff directly to reduce the cost of the traffic control/maintenance, if necessary.

## PROPOSAL STATEMENT PREPARATION

In order to facilitate the evaluation of the Proposals, the Proposer is instructed to follow the outline below in responding. Proposals that do not follow the outline, or do not contain the required information may be considered as unresponsive Proposals. Additional or more detailed information may be annexed to the main body of the Proposal. Proposals shall be submitted in one (1) original set.

### 1. Company or Contractor Team Background Material

The Proposer shall provide information concerning the background of the firm including a brief description of the firm's experience providing similar services. This shall include any proposed subcontractor or consultants that the Proposer plans to engage on this project.

### 2. Experience/References

The Proposer shall provide a Client reference list, with names, addresses, and telephone numbers, especially for clients whom the Proposer has provided similar services in the past. The Proposer should be able to provide a list showing that they have worked on at least one similar project in the last ten (5) years that are of similar size and scope. References shall include a brief description of the project and the services provided.

### 3. Project Approach

The Proposer shall provide cost of the work, including construction techniques and proposed construction materials. The Proposer shall also describe recent similar work

and any other information that the Proposer deems relevant to the project, and which the Proposer believes will further the competitiveness of the Proposal, including work samples, pictures, etc. from similar completed projects.

#### 4. Schedule

The Proposer shall provide a brief description of their ability to meet the construction schedule set forth in this Request for Proposal. In addition, the Proposer shall provide a proposed schedule of construction.

#### 5. Cost Proposal

Proposers shall submit a Cost Proposal in Lump Sum not to exceed format.

### AWARD OF CONTRACT:

### **AWARD OF THE CONTRACT WILL BE SUBJECT TO GRANT APPROVAL IN MID MAY 2023.**

Any contract entered into by the Town shall be in response to the proposal and subsequent discussions. It is the policy of the Town that contracts be awarded, among other considerations, only to responsive and responsible Proposers. In order to qualify as responsive and responsible, a prospective Engineering Firm/Contractor must meet the following standards as they relate to this request:

- Have adequate financial resources for performance or have the ability to obtain such resources as required during performance;
- Have the necessary experience, organization, technical and professional qualifications, skills and facilities;
- Be able to comply with the proposed or required time of completion or performance schedule;
- Have a demonstrated satisfactory record of performance.
- Adhere to the specifications of this proposal and provide all documentation required of this proposal

The contract will be awarded to a responsive and responsible Proposer based cost and experience of the engineering firm/ contractor.

The Town reserves the right to reject any or all proposals or any part thereof, to waive any formality, informality, information and/or errors in the proposal, to accept any proposal in part or in whole as may be in the best interest of the Town, or any other option if it is considered in the best interest of the Town to do so.

This solicitation requires proposing on all items, failure to do so will disqualify the proposal.

### CONTRACT AWARD PROTEST POLICY AND PROCEDURE:

- a. Definitions. As used in this provision:

“Interested party” means an actual or prospective bidder whose direct economic interest would be affected by the award of the contract.

“Protest” means a written objection by an interested party to this solicitation or to a proposed or actual award of a contract pursuant to this solicitation.

- b. Protests shall be served on the Contracting Officer by obtaining written and dated acknowledgement from:

Steve Malizia, Town Administrator  
Town of Hudson  
12 School Street  
Hudson, NH 03051

- c. All protests shall be resolved in accordance with the municipality’s protest policy and procedures, copies of which are maintained at the municipality.

MODIFICATIONS AFTER AWARD:

The Contract shall constitute the entire understanding between the parties, and it shall not be considered modified, altered, changed, or amended in any respect unless in writing and signed by the parties hereto. Such modification shall be in the form of a contract amendment executed by both parties.

CANCELLATION OF AWARD:

The Town reserves the right to cancel the award without liability to the Proposer at any time before a contract has been fully executed by all parties and is approved by the Town.

CONTRACT:

Any Contract between the Town and the Contractor shall consist of (1) the Request for Proposal (RFQ) and any amendments thereto and (2) the Contractor’s proposal in response to the RFQ, (3) Form of Agreement. In the event of a conflict in language between documents (1), (2), and (3) referenced above, the provisions and requirements set forth and referenced in the RFB shall govern. However, the Town reserves the right to clarify any contractual relationship in writing and such written clarification shall govern in case of conflict. In all other matters, not affected by written clarification, if any, the RFQ shall govern. The Proposer is cautioned that this proposal shall be subject to acceptance without further clarification.

EXECUTION OF CONTRACT:

The successful Proposer shall sign (execute) the contract documents and shall satisfy all conditions set forth in the contract to enter into the contract and return such signed documents to the Town, within ten (10) calendar days from the date mailed or otherwise delivered to the successful Proposer.

**AWARD OF THE CONTRACT WILL BE SUBJECT TO GRANT APPROVAL IN MID MAY 2023.**

APPROVAL OF CONTRACT:

Upon receipt of the contract that has been fully executed by the successful Proposer, the Town shall complete the execution of the contract in accordance with local laws or ordinances and return the fully executed contract to the Contractor. Delivery of the fully executed contract, along with a Notice to Proceed and a Town purchase order, to the Contractor shall constitute the Town's approval of the contract with the Contractor.

FAILURE TO EXECUTE CONTRACT:

Failure of the successful Proposer to execute the contract within ten (10) calendar days from the date mailed or otherwise delivered to the successful Proposer shall be just cause for cancellation of the award.

DISQUALIFICATION:

Awards will not be made to any person, firm and/or corporation that has defaulted upon a contract with the Town, the State of New Hampshire or the Federal Government within the past 5 years. Awards will not be made to any principal owner or officers that have a 10% or greater interest in a firm or corporation that has defaulted upon a contract with the Town, the State of New Hampshire or the Federal Government within the past 5 years. Corporations must currently be in good standing with the Secretary of State's Office in the state of incorporation.

INSURANCE:

The successful Proposer shall procure and maintain insurance, in the amounts and coverage as set forth in this Request for Proposals, or otherwise required by the Town, at the Proposer's sole expense, with Town approved insurance companies, insuring against any and all public liability, including injuries or death to persons and damage to property, arising out of or related to the goods or Proposer's performance hereunder and shall furnish to the Town certificates of such insurance and renewals thereof signed by the issuing company or agent upon the Town's request. Such certificates shall name the Town of Hudson as an additional insured. Such policies shall provide for cancellation only subsequent to 30 days prior written notice to the Town and proof of subsequent insurance upon cancellation of prior policy.

The Town's examination of, or failure to request or demand, any evidence of insurance hereunder, shall not constitute a waiver of any requirement and the existence of any insurance shall not limit the Proposer's obligation under any provision hereof.

Except to the extent of comparable insurance acceptable to, or express waiver by the Town, the Proposer shall, or shall cause any carrier engaged by the Proposer, to insure all shipments of goods for full value.

If the contract with the Proposer involves the performance of work by the Proposer's employees at property owned or leased by the Town, the Proposer shall furnish such additional insurance as the Town may request in respect thereof, but in any event and without such request, workers' compensation insurance and unemployment compensation insurance as required by laws of the State of New Hampshire and public and automotive liability and property damage insurance. In no event shall such employees of the Proposer be deemed to be the employees of, or under the direction or control of the Town for any purpose whatsoever.

WORKER'S COMPENSATION:

All Proposers and subcontractors at every tier under the Proposer will conform with the requirements of RSA 281 Title XXIII, Section 281-A:2 with close attention to sections VI(a), VI(c) and VII(a) as well as Section 281-A:4.

DISAGREEMENTS AND DISPUTES:

All disagreements and disputes, if any, arising under the terms of any contract, either by law, in equity, or by arbitration, shall be resolved pursuant to the laws and procedures of the State of New Hampshire, in which state any contract shall be deemed to have been executed. No action at law, or equity, or by arbitration shall be commenced to resolve any disagreements or disputes under the terms of any contract, in any jurisdiction whatsoever other than the State of New Hampshire and Hillsborough County.

TERMINATION OF CONTACT FOR CAUSE:

If the Contractor shall violate any provision of the Contract, the Town shall have the right to terminate the Contract. To terminate the Contract, the Town shall provide written notice to the Contractor of such termination. Such written notice shall state the Contract violation(s) and be delivered to the Contractor's address as identified in the Contract Documents. This notice shall provide the Contractor with fifteen (15) calendar days from the date of delivery, to correct the violation(s) to the Town's satisfaction. Should the Contractor fail to satisfactorily correct all violations within (15) fifteen calendar days, the Town may terminate the contract immediately upon delivery of a Notice of Termination to the Contractor. Such termination shall become effective immediately or as otherwise determined by the Town. Upon termination, all finished or unfinished work, services, plans, data programs and reports prepared by the Contractor under the Contract shall become the Town's property. The Town may also terminate this Contract in accordance with any other applicable Contract provision.

Notwithstanding the above, the Contractor shall not be relieved of liability to the Town for damages sustained by the Town by virtue of any breach of any contract, and the Town may

withhold any payments until such time as the exact amount of damages due the Town is determined.

TERMINATION FOR THE CONVENIENCE OF THE TOWN:

The Town may terminate any contract at any time by giving written notice to the Vendor of such termination and specifying the effective date thereof, at least fifteen (15) days before the effective date of such termination.

In that event, all finished or unfinished work, services, documents and materials shall become the Town's property. If any Contract is terminated by the Town as provided herein, the Vendor will be paid an amount which bears the same ratio to the total compensation as the services covered by any contract, less payments of compensation previously made.

PATENT PROTECTION:

The successful Proposer agrees to indemnify and defend the Town of Hudson from all claims and losses resulting from alleged and actual patent infringements and further agrees to hold the Town of Hudson harmless from any liability arising under RSA 382-A, 2-312 (3). (Uniform Commercial Code).

OWNERSHIP OF REPORTS:

All data, materials, plans, reports and documentation prepared pursuant to any contract between the Town of Hudson and the successful Proposer shall belong exclusively to the Town.

ASSIGNMENT PROVISION:

The successful Proposer hereby agrees that it will assign to the Town of Hudson all cause of action that it may acquire under the anti-trust laws of New Hampshire and the United States as the result of conspiracies, combination of contracts in restraint of trade which affect the price of goods or services obtained by the Town under this contract if so requested by the Town of Hudson.

PAYMENT:

Payment will be made within thirty (30) days of the completion of the work based upon the payment schedule listed in the Form of Agreement after receipt of invoice by the Town.

TAX:

The Town is exempt from all sales and Federal excise taxes. The Town's tax exemption certificate will be provided to the successful Contractor upon request. Please bill less these taxes.

#### FUNDING OUT:

The Town of Hudson's obligations to pay any amount due under a contract are contingent upon availability and continuation of funds for the purpose. The Town may terminate the contract at any time, due to the non-appropriation of funds, and all payment obligations of the Town cease on the date of termination.

#### ASSIGNMENT OR SUB-CONTRACTING:

None of the work or services covered by the contract shall be assigned in full or in part, or sub-contracted without the prior approval of the Town.

#### PRICING:

Unless otherwise specified all prices listed are firm for the term of the contract. All prices should include all labor, material and transportation costs, and any discounts offered. No fuel surcharges shall be allowed at any time.

#### AUDIT:

For a period of at least three (3) years after completion of any contract, it is the responsibility of the Contractor to make available at the Contractor's place of business, upon demand, all price lists, documents, financial records and other records pertaining to purchases made and /or work performed under contract for the purposes of audit by the Town of Hudson.

#### INSPECTION & EVALUATION:

The Town of Hudson reserves the right to inspect the Contractor's facilities during operating hours to determine that the level of inventory is adequate for the Town's needs. The conditions and operations of the facility shall be taken into consideration in making the award of this contract.

#### FUGITIVE NOISE ORDINANCES

All work shall be conducted in conformance with the Town's Code Part II General Legislation

1. Chapter 249-4, Prohibited Noise Emissions and Conditions

The Town Code can be viewed on-line at <http://ecode360.com/HU1110>

#### GUARANTEES & WARRANTY:

All parts and labor related to contracts must be guaranteed and include a 12 month warranty from the date of acceptance by the Town. If any work is unable to be guaranteed, the contractor must inform the Town, in writing, prior to the delivery of an item or any work being performed. Non-guaranteed work must be offered at a discount rate from the proposal



prices. **Inspection, testing and final determination of non-warranty work shall be performed at no cost to the Town.**

FORCE MAJEURE:

Neither party shall be liable for any inability to perform its' obligations under any subsequent contract due to war, riot, insurrection, civil commotion, fire, flood, earthquake, storm or other act of God.

SEVERABILITY:

If any of this Request for Proposals or subsequent contract are held to be invalid or unenforceable, it will be construed to have the broadest interpretation which would make it valid and enforceable under such holding. Invalidity or the inability to enforce a term or condition will not affect any of the other this Request for Proposals or subsequent contract.

PROVISION REQUIRED BY LAW DEEM INSERTED

Each and every provision and clause required by law to be inserted in this Request for Proposals and any subsequent Contract shall be deemed to be inserted herein and this Request for Proposals and Contract shall be read and enforced as though it were included herein, and if through mistake or otherwise any such provision is not inserted, or is not correctly inserted, then upon the application of either party, the Request for Proposals and/or Contract shall forthwith be physically amended to make such insertion or correction.

DISADVANTAGED BUSINESS ENTERPRISES

The Town hereby notifies all Contractors that it will affirmatively insure that in any contract entered into pursuant to this Request for Proposals, disadvantaged business enterprises will be afforded full opportunity to submit proposals in response to this request and will not be discriminated against on the grounds of race, color, national origin, religion, sex, age or disability in consideration for an award.

NON-DISCRIMINATION

Contracts for work resulting from this Request for Proposals shall obligate the Contractor and the Contractor's subcontractors not to discriminate in employment practices on the grounds of race, color, national origin, religion, sex, age or disability. Statements as to non-discriminatory practices may be requested from the successful Vendor(s).

DEFINITIONS:

Proposal shall also mean quotation, bid, offer and qualification/experience statement.

Vendors shall also mean Proposers, offerors, bidders, contractors or any person or firm responding to a Request for Proposals.

Contract shall also mean agreement.

GOVERNING LAW:

The Laws of the State of New Hampshire shall govern all contracts entered into by the Town of Hudson. Any disputes shall be resolved within the venue of the State of New Hampshire and Hillsborough County.

*FAILURE TO ACKNOWLEDGE THIS REQUEST FOR PROPOSALS MAY RESULT IN WITHDRAWAL FROM THE PROPOSAL LIST FOR THIS COMMODITY OR SERVICE.*

*FAILURE TO COMPLY WITH THESE REQUIREMENTS COULD RESULT IN THE CANCELLATION OF AN ORDER OR CONTRACT.*

## **PROPOSAL SUBMISSION CHECKLIST**

In order to be considered responsive, each prospective vendor must submit the following documents, in **one (1) original and one (1) identical copy** as part of its proposal:

1. Proposal Document as outlined above
2. Specifications Exception Form
3. Alternate Form W-9
4. Town of Hudson Indemnification Agreement

**The successful contractor must submit, prior to contract signing, its insurance certificate (naming the Town of Hudson) that meets the minimum required types and levels of coverage. In addition, as noted in the RFP the Contract will be required to provide and Performance and Payment bond to the Town.**



**BID FORM**

**CONSTRUCTION SERVICES FOR FREEDOM FIELD REHABILITATION,  
TOWN OF HUDSON, NEW HAMPSHIRE**

THE UNDERSIGNED HEREBY OFFERS TO PROVIDE CONSTRUCTION SERVICES FOR THE PROJECT LISTED ABOVE FOR THE FOLLOWING PRICES

**1. Construction Services :**

Construction services for the project listed above.

\$ \_\_\_\_\_

Delivery/Completion Date

\_\_\_\_\_

---

Length of the warranty for labor shall be one year from the date of Project acceptance

Length of the warranty for materials shall be one year from the date of Project acceptance

The warranty shall include parts, labor, and travel to and from the site to remedy any warranty repairs.

The undersigned acknowledges:

1. That he/she is an authorized agent of the vendor submitting this proposal
2. The receipt of the following addenda:  
  
\_\_\_\_\_
3. The firm submitting this bid has never defaulted on any municipal, state, federal or private contract
4. The undersigned hereby certifies that he is able to furnish labor that can work in harmony with all other elements of labor employed or to be employed on the work.
5. The undersigned hereby certifies that he (has) (has not) (CIRCLE ONE) performed work subject to the President's Executive Order No. 11246 entitled "Equal Employment Opportunity."
6. The undersigned hereby acknowledges that he has read this proposal in its entirety and understands and agrees to all provisions contained herein.

**Company:** \_\_\_\_\_

**Signed by:** \_\_\_\_\_

**Printed or typed name:** \_\_\_\_\_

**Address:** \_\_\_\_\_

**Telephone number:** \_\_\_\_\_ **fax number:** \_\_\_\_\_

**Toll free number:** \_\_\_\_\_ **e-mail:** \_\_\_\_\_

**Cell phone number:** \_\_\_\_\_

**Primary point of contact:** \_\_\_\_\_

**Payment terms and conditions:** \_\_\_\_\_

**Please fill out, sign and return to:**

Hudson Town Clerk's Office  
12 School Street, Hudson, NH 03051  
603-886-6003 (Tel)  
603-594-1142 (Fax)

**Due Date/Time: MAY 30, 2023, Not Later Than 10:00 AM**

**SPECIFICATIONS EXCEPTION FORM**

**CONSTRUCTION SERVICES FOR  
FREEDOM FIELD MODIFICATIONS  
TOWN OF HUDSON, NEW HAMPSHIRE**

It is mandatory that you state any exceptions taken by you to our specifications.

If your bid/quotation does not meet all of our specifications, you **must** so state in the space provided below. Additional exceptions may be listed on a separate page and attached to this form.

---

---

---

---

Proposals on equipment, vehicles, supplies, service and materials not meeting specifications may be considered by the Town, however, all deviations must be listed above.

Signed: \_\_\_\_\_  
**I DO** meet specifications

Signed: \_\_\_\_\_  
**I DO NOT** meet specifications as listed in this bid; exceptions are in the space provided.

Failure to submit this form with your RFP response may result in your Proposal being rejected as unresponsive.





Name (as shown on your income tax return)		
Business name/disregard entity name, if different from above		
Check appropriate box for federal tax classification (required): <input type="checkbox"/> Individual/ Sole proprietor	<input type="checkbox"/> C Corporation	<input type="checkbox"/> S Corporation
<input type="checkbox"/> Partnership	<input type="checkbox"/> Trust/estate	
<input type="checkbox"/> Limited Liability Company – Enter the tax classification (C= Corporation, S-S Corporation, P= Partnership)_____		<input type="checkbox"/> Exempt payee
<input type="checkbox"/> Other (see instructions)		
Address (number, street, and apt. or suite no.)	Requester's name and address (optional)	
City, state, and ZIP code	City of Concord 41 Green Street Concord NH 03301	
List account number(s) here (optional)		

<b>Part I</b>	<b>Taxpayer Identification Number (TIN)</b>
---------------	---

Enter your TIN in the appropriate box. The TIN provided must match the name given on the "Name" line to avoid backup withholding. For individuals, this is your social security number (SSN). However, for a resident alien, sole proprietor, or disregarded entity, see the Part I instructions on page 3. For other entities, it is your employer identification number (EIN). If you do not have a number, see *How to get a TIN* on page 3. **Note.** If the account is in more than one name, see the chart on page 4 for guidelines on whose number to enter.

Social Security number –	Employer identification number –
--------------------------	----------------------------------

<b>Part II</b>	<b>Certification</b>
----------------	----------------------

Under penalties of perjury, I certify that:

1. The number shown on this form is my correct taxpayer identification number (or I am waiting for a number to be issued to me),
2. I am not subject to backup withholding because: (a) I am exempt from backup withholding, or (b) I have not been notified by the Internal Revenue Service (IRS) that I am subject to backup withholding as a result of a failure to report all interest or dividends, or (c) the IRS has notified me that I am no longer subject to backup withholding, and
3. I am a U.S. citizen or other U.S. person (defined below).

Certification instructions: You must cross out item 2 above if you have been notified by the IRS that you are currently subject to backup withholding because you have failed to report all interest and dividends on your tax return. For real estate transactions, item 2 does not apply. For mortgage interest paid, acquisition or abandonment of secured property, cancellation of debt, contributions to an individual retirement arrangement (IRA), and generally, payments other than interest and dividends, you are not required to sign the certification, but you must provide your correct TIN. See the instructions on page 4.

<b>Sign Here</b>	<b>Signature of U.S. Person</b>	<b>Date:</b>
------------------	---------------------------------	--------------

**General Instructions**

Section references are to the Internal Revenue Code unless otherwise noted.

**Purpose of Form**

A person who is required to file an information return with the IRS must obtain your correct taxpayer identification number (TIN) to report, for example, income paid to you, real estate transactions, mortgage interest you paid, acquisition or abandonment of secured property, cancellation of debt, or contributions you made to an IRA. Use Form W-9 only if you are a U.S. person (including a resident alien), to provide your correct TIN to the person requesting it (the requester) and, when applicable, to: 1. Certify that the TIN you are giving is correct (or you are waiting for a number to be issued), 2. Certify that you are not subject to backup withholding, or 3. Claim exemption from backup withholding if you are a U.S. exempt payee. If applicable, you are also certifying that as a U.S. person, your allocable share of any partnership income from a U.S. trade or business is not subject to the withholding tax on foreign partners' share of effectively connected income. **Note.** If a requester give you a form other than Form W-9 to request your TIN, you must use the requester's form if it is substantially similar to this Form W-9. Pursuant to IRS Regulations, you must furnish your Taxpayer IRS Identification Number (TIN) to the City whether or not you are required to file tax returns. If this number is not provided, you may be subject to required withholding on each payment made to you. To avoid this withholding & to ensure that accurate tax information is reported to the IRS, **A RESPONSE IS REQUIRED.**



**CONSTRUCTION SERVICES FOR  
FREEDOM FIELD MODIFICATIONS  
TOWN OF HUDSON, NEW HAMPSHIRE**

**THE FOLLOWING INDEMNIFICATION AGREEMENT SHALL BE, AND IS  
HEREBY A PROVISION OF ANY CONTRACT**

The successful contractor agrees to indemnify, defend and save harmless the Town, its officials, officers, agents and employees from any and all claims and losses accruing or resulting to any and all contractors, subcontractors, suppliers, laborers and any other person, firm, or corporation furnishing or supplying work, services, materials or supplies in connection with the performance of this contract, and from any and all claims and losses accruing or resulting to any person, firm or corporation which may be injured or damaged by the contractor in the performance of this contract. In any case, the foregoing provisions concerning indemnification shall not be construed to indemnify the Town for damage arising out of bodily injury to persons or damage to property caused by or resulting from the sole negligence of the Town or its employees. This indemnification shall survive the expiration or early termination of this contract.

**Company** \_\_\_\_\_

**Taxpayer identification number** \_\_\_\_\_

**Authorized signature** \_\_\_\_\_

**Date** \_\_\_\_\_

**Address** \_\_\_\_\_

**Telephone** \_\_\_\_\_

**Toll-free number** \_\_\_\_\_

**Fax number** \_\_\_\_\_

**E-mail address** \_\_\_\_\_



**CONSTRUCTION SERVICES FOR  
FREEDOM FIELD MODIFICATIONS  
Town of Hudson  
Insurance Requirements for All Contractors**

*Additional Coverage is Required if Checked* *Minimum Limits Required*

**Commercial General Liability**

General Aggregate	\$2,000,000
Products-Completed Operations Agg.	\$2,000,000
Personal and Advertising	\$1,000,000
Each Occurrence Injury	\$1,000,000
Fire Damage (Any One Fire)	\$ 50,000
Medical Expense (Any One Person)	\$ 5,000

- Occurrence
- Claims Made

**Additional Coverage to Include**

<input type="checkbox"/> Owners & Contractors' Protective – Limit	NA
<input type="checkbox"/> Underground/Explosion and Collapse	NA

**Commercial Automobile Liability**

Combined Single Limit	\$1,000,000
-----------------------	-------------

- Any Auto, Symbol 1
- Include Employees as Insured

**Additional Coverage to include:**

<input type="checkbox"/> Garage Liability	NA
<input type="checkbox"/> Garage Keepers Legal Liability	NA

**Workers Compensation**

NH Statutory including Employers Liability - Each Accident/Disease-Policy Limit/Disease-Each Employee	\$100,000/\$500,000/\$100,000
--	-------------------------------

**Commercial Umbrella**

May be substituted for higher limits required above	\$ <u>1,000,000</u>
<input checked="" type="checkbox"/> Follow Form Umbrella on ALL requested Coverage	

**Other**

<input type="checkbox"/> 1. Professional/Errors & Omissions	NA
<input type="checkbox"/> 2. Builders Risk – Renovation Form	
All Risk completed value form including Collapse	NA
Sublimit for Soft Cost Coverage	NA
<input type="checkbox"/> 3. Installation Floater (Equipment)	NA
<input type="checkbox"/> 4. Riggers Liability	NA
<input type="checkbox"/> 5. Environmental – Pollution Liability	NA
<input type="checkbox"/> 6. Aviation Liability	NA
<input type="checkbox"/> 7. Watercraft – Protection & Indemnity	NA

(X) **The Town of Hudson must be named as Additional Insured with respect to general, automobile and umbrella liability**



**NOTICE OF AWARD**

Dated \_\_\_\_\_, 2023

TO: \_\_\_\_\_  
(BIDDER)

ADDRESS: \_\_\_\_\_

OWNER'S PROJECT NO: \_\_\_\_\_

PROJECT: Construction Service for Freedom Field Modifications

OWNER'S CONTRACT NO: \_\_\_\_\_

CONTRACT FOR: Construction Service for Freedom Field Modifications

\_\_\_\_\_  
(Insert name of contract as it appears in the Bid Documents)

You are notified that your Bid dated \_\_\_\_\_ for the above Contract has been considered. You are the apparent successful bidder and have been awarded a contract for:

Hudson – RFP 23

Construction Service for Freedom Field Modifications

\_\_\_\_\_  
(Indicate total Work, alternates or sections of Work awarded)

The Contract Price of your contract is

\_\_\_\_\_ Dollars (\$) \_\_\_\_\_).

4 (four) copies of each of the proposed Form of Agreement, and Performance and Payment Bond forms accompany this Notice of Award.

You must comply with the following conditions precedent within **five** days of receiving this Notice of Award.

1. You must deliver to the OWNER all of the fully executed counterparts of the Agreement.
2. You must deliver with the executed Agreement the Contract Security (Bonds) as specified in the Information for Bidders and General Provisions.
3. (List other conditions precedent).

---

List of subcontractors

---

Insurance Certificates (1 copies) -

---

**The Municipality must be named as additional insureds.**

---

---

---

---

---

---

---

---

---

---

Failure to comply with these conditions within the time specified will entitle **OWNER** to consider your bid abandoned, to annul this Notice of Award and to declare your Bid Security forfeited.

Within ten days after receipt of acceptable performance BOND, payment BOND and agreement signed by the party to whom the Agreement was awarded, the **OWNER** will return to you one fully signed counterpart of the Agreement with the Contract Documents attached.

Town of Hudson  
(OWNER)

---

By \_\_\_\_\_  
(Authorized Signature)

\_\_\_\_\_  
(TITLE)

ACCEPTANCE OF NOTICE

Receipt of the above NOTICE OF AWARD is hereby acknowledged

By \_\_\_\_\_

The \_\_\_\_\_ day of \_\_\_\_\_, 20 \_\_\_\_\_

By \_\_\_\_\_

Title \_\_\_\_\_

Copy to ENGINEER  
(Use Certified Mail, Return Receipt Requested)



**FORM OF AGREEMENT  
BETWEEN OWNER AND CONTRACTOR  
ON THE BASIS OF A LUMP SUM PRICE**

**THIS AGREEMENT** is dated as of the \_\_\_\_\_ day of \_\_\_\_\_ in the year 2023 by and between the Town of Hudson, 12 School Street, Hudson, NH (hereinafter called OWNER) and \_\_\_\_\_ (hereinafter called CONTRACTOR).

OWNER and CONTRACTOR, in consideration of the mutual covenants hereinafter set forth, agree as follows:

**ARTICLE 1 - WORK**

CONTRACTOR shall complete all Work as specified or indicated in the Contract Documents. The Work is generally described as follows:

**CONSTRUCTION SERVICES FOR  
FREEDOM FIELD MODIFICATIONS  
HUDSON, NEW HAMPSHIRE**

**ARTICLE 2 - ENGINEER**

The Project is being managed by the Town Engineer with assistance from \_\_\_\_\_, who is to act as OWNER's representative, assume all duties and responsibilities and have the rights and authority assigned to ENGINEER in the Contract Documents in connection with completion of the Work in accordance with the Contract Documents.

**ARTICLE 3 - CONTRACT PRICE**

OWNER shall pay CONTRACTOR for completion of the Work in accordance with the Contract Documents an amount equal to the sum of the Lump Sum Cost as shown on the Proposal Form (attached).

3.1 Liquidated Damages: OWNER and CONTRACTOR recognize that time is of the essence of this Agreement and that if the Work is not completed within the times specified, plus any extensions thereof allowed in accordance with the General Conditions, the OWNER and CONTRACTOR agree that as liquidated damages for delay (but not as a penalty) the OWNER shall deduct from payments due the CONTRACTOR **Two Hundred and Fifty (\$250.00)** for each calendar day that expires past the date for each calendar day that expires after the Substantial Completion date specified, until said portions of the work have been completed. If payments due the CONTRACTOR are less than the amount of such liquidated damages, said damages shall be deducted from any other monies due or to become due the CONTRACTOR, and then the CONTRACTOR or his Surety shall pay the balance to the OWNER.

- 3.2 In addition to the above, if the Contract is not completed within the time specified and no extension of time is authorized by the OWNER, the CONTRACTOR shall indemnify the OWNER for costs to the OWNER of additional engineering work required during any such extension period.

#### **ARTICLE 4 - PAYMENT PROCEDURES**

CONTRACTOR shall submit Applications for Payment in accordance with the General Conditions and Supplemental Conditions. Applications for Payment will be processed by ENGINEER as follows:

- Payment will be made within thirty (30) days of submittal

The Town waives any retainage requirement for this project. All payments to the Contractor will be based on the payment schedule noted above.

#### **ARTICLE 5 - INTEREST**

All monies not paid when due as provided in the General Conditions shall bear interest at the maximum rate allowed by law at the place of the Project.

#### **ARTICLE 6 - CONTRACTOR'S REPRESENTATIONS**

In order to induce OWNER to enter into this Agreement CONTRACTOR makes the following representations:

- 7.1 CONTRACTOR has examined and carefully studied the Contract Documents including the Addenda and the other related data identified in the Bidding Documents including "technical data".
- 7.2 CONTRACTOR has visited the site and become familiar with and is satisfied as to the general, local and site conditions that may affect cost, progress, performance or furnishing of the Work.
- 7.3 CONTRACTOR is familiar with and is satisfied as to all federal, state and local Laws and Regulations that may affect cost, progress, performance and furnishing of the Work.
- 7.4 CONTRACTOR has obtained and carefully studied (or assumes responsibility for having done so) all such additional supplementary examinations, investigations, explorations, tests, studies and data concerning conditions (surface, subsurface and Underground Facilities) at or contiguous to the site or otherwise which may affect cost, progress, performance or furnishing of the Work or which relate to any aspect of the means, methods, techniques, sequences and procedures of construction to be employed by CONTRACTOR and safety precautions and programs incident thereto. CONTRACTOR does not consider that any additional examinations, investigations, explorations, tests, studies or data are necessary for the performance and furnishing of the Work at the Contract Price, within the Contract Times and in accordance with the other terms and conditions of the Contract Documents.

- 7.5 CONTRACTOR has correlated the information known to CONTRACTOR, information and observations obtained from visits to the site, reports and drawings identified in the Contract Documents and all additional examinations, investigations, explorations, tests, studies and data with the Contract Documents.
- 7.6 CONTRACTOR has given ENGINEER written notice of all conflicts, errors, ambiguities or discrepancies that CONTRACTOR has discovered in the Contract Documents and the written resolution thereof by ENGINEER is acceptable to CONTRACTOR, and the Contract Documents are generally sufficient to indicate and convey understanding of all terms and conditions for performance and furnishing of the Work.

## **ARTICLE 7 - CONTRACT DOCUMENTS**

The Contract Documents which comprise the entire agreement between OWNER and CONTRACTOR concerning the Work consist of the following:

- 7.1 Request for Proposal RFP 2023.
- 7.2 Town of Hudson required contract forms:
- a.) Proposal Document
  - b.) Specifications Exception Form
  - d.) Alternate Form W-9
  - e.) Indemnification Agreement
  - f.) Amendment, if any
- 7.3 Bid Bond.
- 7.4 Notice of Award.
- 7.5 This Agreement.
- 7.6 Performance Bond.
- 7.7 CONTRACTOR's Proposal.
- 7.8 Documentation submitted by CONTRACTOR prior to Notice of Award (pages \_\_ to \_\_\_\_, inclusive).
- 7.9 The following which may be delivered or issued after the Effective Date of the Agreement and are not attached hereto: All Written Amendments and other documents amending, modifying or supplementing the Contract Documents pursuant to the General Conditions.

## ARTICLE 8 - MISCELLANEOUS

- 8.1 Terms used in this Agreement which are defined in the General Conditions will have the meanings indicated in the General Conditions.
- 8.2 No assignment by a party hereto of any rights under or interests in the Contract Documents will be binding on another party hereto without written consent of the party sought to be bound; and, specifically but without limitation, monies that may become due and monies that are due may not be assigned without such consent (except to the extent that the effect of this restriction may be limited by law), and unless specifically stated to the contrary in any written consent to an assignment no assignment will release or discharge the assignor from any duty or responsibility under the Contract Documents.
- 8.3 OWNER and CONTRACTOR each binds itself, its partners, successors, assigns and legal representatives to the other party hereto, its partners, successors, assigns and legal representatives in respect to all covenants, agreements and obligations contained in the Contract Documents.
- 8.4 Any provision or part of the Contract Documents held to be void or unenforceable under any Law or Regulation shall be deemed stricken, and all remaining provisions shall continue to be valid and binding upon OWNER and CONTRACTOR, who agree that the Contract Documents shall be reformed to replace such stricken provision or part thereof with a valid and enforceable provision that comes as close as possible to expressing the intention of the stricken provision.

IN WITNESS WHEREOF, OWNER and CONTRACTOR have signed this Agreement in triplicate. One counterpart each has been delivered to OWNER, CONTRACTOR and ENGINEER. All portions of the Contract Documents have been signed, initialed or identified by OWNER and CONTRACTOR or identified by ENGINEER on their behalf.

This Agreement will be effective on \_\_\_\_\_, 2023 (which is the Effective Date of the Agreement).

OWNER Town of Hudson

CONTRACTOR \_\_\_\_\_

By: \_\_\_\_\_

By: \_\_\_\_\_

Print Name \_\_\_\_\_

Print Name \_\_\_\_\_

Title: \_\_\_\_\_

Title: \_\_\_\_\_

STATE OF NEW HAMPSHIRE  
COUNTY OF \_\_\_\_\_

STATE OF \_\_\_\_\_  
COUNTY OF \_\_\_\_\_

The foregoing instrument was acknowledged before me this \_\_\_\_ day of \_\_\_\_\_, 2023, by \_\_\_\_\_, duly authorized \_\_\_\_\_ of \_\_\_\_\_, a New Hampshire corporation, on behalf of same.

The foregoing instrument was acknowledged before me this \_\_\_\_ day of \_\_\_\_\_ 2023, by \_\_\_\_\_, duly authorized \_\_\_\_\_ of \_\_\_\_\_, a \_\_\_\_\_ corporation, on behalf of same.

\_\_\_\_\_  
Justice of the Peace/Notary Public

\_\_\_\_\_  
Justice of the Peace/Notary Public

Address for giving notices:

Address for giving notices:

Town of Hudson, 12 School Street,

\_\_\_\_\_

Hudson, New Hampshire

\_\_\_\_\_

(If OWNER is a public body, attach evidence of authority to sign and resolution of other documents authorizing execution of Agreement.

NH License No.: \_\_\_\_\_

Agent for service of process: \_\_\_\_\_

\_\_\_\_\_

(If CONTRACTOR is a corporation, attach evidence of authority to sign).



**PERFORMANCE BOND**

**KNOW ALL MEN BY THESE PRESENTS:** that

\_\_\_\_\_  
(Name of Contractor)

\_\_\_\_\_  
(Address of Contractor)

a \_\_\_\_\_, hereinafter called Principal,  
(Corporation, Partnership or Individual)

and \_\_\_\_\_  
(Name of Surety)

\_\_\_\_\_  
(Address of Surety)

hereinafter called Surety, are held and firmly bound unto

Town of Hudson, NH

\_\_\_\_\_  
(Name of Owner)

12 School Street, Hudson, NH 03051

\_\_\_\_\_  
(Address of Owner)

hereinafter called **OWNER**, in the total aggregate penal sum of \_\_\_\_\_ Dollars, \$ ( \_\_\_\_\_ )

in lawful money of the United States, for the payment of which sum well and truly to be made, we bind ourselves, our heirs, executors, administrators' successors, and assigns, jointly and severally, firmly by these presents.

**THE CONDITION OF THIS OBLIGATION** is such that whereas, the Principal entered into a certain contract with the **OWNER**, dated the \_\_\_\_\_ day of \_\_\_\_\_ 20 \_\_\_\_, a copy of which is hereto attached and made a part hereof for the construction of:

FREEDOM FIELD MODIFICATIONS

\_\_\_\_\_  
Hudson, NH

**NOW, THEREFORE**, if the Principal shall well, truly and faithfully perform its duties, all the undertakings, covenants, terms, conditions, and agreements of said contract during the original term thereof, and any extension thereof which may be granted by the **OWNER**, with or without notice to the Surety and during the one year guaranty period, and if the **PRINCIPAL** shall satisfy all claims and demands incurred under such contract, and shall fully indemnify and save harmless the **OWNER** from all costs and damages which it may suffer by reason of failure to do so, and shall reimburse and repay the **OWNER** all outlay and expense which the **OWNER** may incur in making good any default, then this obligation shall be void: otherwise to remain in full force and effect.

PROVIDED, FURTHER, that the said surety, for value received hereby stipulates and agrees that no change, extension of time, alteration or addition to the terms of the contract or to WORK to be performed thereunder or the specifications accompanying same shall in any way affect its obligation on this BOND, and it does hereby waive notice of any such change, extension of time alteration or addition to the terms of the contract or to the WORK or to the specifications.

PROVIDED, FURTHER, that it is expressly agreed that this BOND shall be deemed amended automatically and immediately, without formal and separate amendments hereto, upon amendment to the Contract not increasing the contract price more than 20 percent, so as to bind the PRINCIPAL and the SURETY to the full and faithful performance of the Contract as so amended. The term "Amendment", wherever used in this BOND and whether referring to this BOND, the contract or the loan Documents shall include any alteration, addition, extension or modification of any character whatsoever.

PROVIDED, FURTHER, that no final settlement between the OWNER and the CONTRACTOR shall abridge the right of any beneficiary hereunder, whose claim may be unsatisfied.

IN WITNESS WHEREOF, this instrument is executed in \_\_\_\_\_ counterparts, each one of which shall be deemed an original, this \_\_\_\_\_ day of \_\_\_\_\_, 20 \_\_\_\_ .

**ATTEST:**

By: \_\_\_\_\_  
(Principal) Secretary

(SEAL)

\_\_\_\_\_  
Principal

**BY**

\_\_\_\_\_

\_\_\_\_\_  
(Address)

By: \_\_\_\_\_  
Witness as to Principal

\_\_\_\_\_  
(Address)

\_\_\_\_\_

\_\_\_\_\_  
(Surety)

**ATTEST:**

By \_\_\_\_\_  
Witness as to Surety

\_\_\_\_\_

\_\_\_\_\_  
(Address)

**BY**

\_\_\_\_\_

\_\_\_\_\_  
Attorney - in - Fact

\_\_\_\_\_  
(Address)

\_\_\_\_\_

\_\_\_\_\_

NOTE: Date of BOND must not be prior to date of Contract.

If CONTRACTOR is Partnership, all partners should execute BOND

IMPORTANT: Surety companies executing BONDS must appear on the Treasury Department's most current list (Circular 570 as amended) and be authorized to transact business in the State of New Hampshire



# BID BOND

Any singular reference to Bidder, Surety, Owner, or other party shall be considered plural where applicable.

---

BIDDER (Name and Address):

SURETY (Name and Address of Principal Place of Business):

OWNER (Name and Address):

## BID

Bid Due Date:

Project (Brief Description Including Location):

## BOND

Bond Number:

Date (Not later than Bid due date):

Penal Sum: \_\_\_\_\_

(Words)

(Figures)

Surety and Bidder, intending to be legally bound hereby, subject to the terms printed on the reverse side hereof, do each cause this Bid Bond to be duly executed on its behalf by its authorized officer, agent, or representative.

## BIDDER

## SURETY

\_\_\_\_\_  
Bidder's Name and Corporate Seal (Seal)

\_\_\_\_\_  
Surety's Name and Corporate Seal (Seal)

By: \_\_\_\_\_  
Signature and Title

By: \_\_\_\_\_  
Signature and Title  
(Attach Power of Attorney)

Attest: \_\_\_\_\_  
Signature and Title

Attest: \_\_\_\_\_  
Signature and Title

Note: Above addresses are to be used for giving required notice.

1. Bidder and Surety, jointly and severally, bind themselves, their heirs, executors, administrators, successors, and assigns to pay to Owner upon default of Bidder any difference between the total amount of Bidder's Bid and the total amount of the Bid of the next lowest, responsible Bidder who submitted a responsive Bid as determined by Owner for the work required by the Contract Documents, provided that:

- 1.1. If there is no such next Bidder, and Owner does not abandon the Project, then Bidder and Surety shall pay to Owner the penal sum set forth on the face of this Bond, and
- 1.2. In no event shall Bidder's and Surety's obligation hereunder exceed the penal sum set forth on the face of this Bond.

2. Default of Bidder shall occur upon the failure of Bidder to deliver within the time required by the Bidding Documents (or any extension thereof agreed to in writing by Owner) the executed Agreement required by the Bidding Documents and any performance and payment bonds required by the Bidding Documents.

3. This obligation shall be null and void if:

- 3.1. Owner accepts Bidder's Bid and Bidder delivers within the time required by the Bidding Documents (or any extension thereof agreed to in writing by Owner) the executed Agreement required by the Bidding Documents and any performance and payment bonds required by the Bidding Documents, or
- 3.2. All Bids are rejected by Owner, or
- 3.3. Owner fails to issue a Notice of Award to Bidder within the time specified in the Bidding Documents (or any extension thereof agreed to in writing by Bidder and, if applicable, consented to by Surety when required by Paragraph 5 hereof).

4. Payment under this Bond will be due and payable upon default by Bidder and within 30 calendar days after receipt by Bidder and Surety of written notice of default from Owner, which notice will be given with reasonable promptness, identifying this Bond and the Project and including a statement of the amount due.

5. Surety waives notice of any and all defenses based on or arising out of any time extension to issue Notice of Award agreed to in writing by Owner and Bidder, provided that the total time for issuing Notice of Award including extensions shall not in the aggregate exceed 120 days from Bid due date without Surety's written consent.

6. No suit or action shall be commenced under this Bond prior to 30 calendar days after the notice of default required in Paragraph 4 above is received by Bidder and Surety and in no case later than one year after Bid due date.

7. Any suit or action under this Bond shall be commenced only in a court of competent jurisdiction located in the state

in which the Project is located.

8. Notices required hereunder shall be in writing and sent to Bidder and Surety at their respective addresses shown on the face of this Bond. Such notices may be sent by personal delivery, commercial courier, or by United States Registered or Certified Mail, return receipt requested, postage pre-paid, and shall be deemed to be effective upon receipt by the party concerned.

9. Surety shall cause to be attached to this Bond a current and effective Power of Attorney evidencing the authority of the officer, agent, or representative who executed this Bond on behalf of Surety to execute, seal, and deliver such Bond and bind the Surety thereby.

10. This Bond is intended to conform to all applicable statutory requirements. Any applicable requirement of any applicable statute that has been omitted from this Bond shall be deemed to be included herein as if set forth at length. If any provision of this Bond conflicts with any applicable statute, then the provision of said statute shall govern and the remainder of this Bond that is not in conflict therewith shall continue in full force and effect.

11. The term "Bid" as used herein includes a Bid, offer, or proposal as applicable.

**HUDSON RF 23  
FREEDOM FIELD  
HUDSON, NEW HAMPSHIRE  
BID FORM**

Notes:

1. All prices must be written in ink. Unit prices must be written in words as well as figures for the entire proposal. In case of discrepancy, the amount in words shall govern.
2. All prices given shall include items delineated in the Measurement and Payment Section, and in accordance with the Drawings, Specifications and Contract Documents.

Item No.	Description	Quantity	Unit	Unit Price	Total Price
201.1	Clearing and Grubbing (F) _____ dollars and _____ cents.	0.20	A	\$ _____	\$ _____
202.8	Removal of Fence _____ dollars and _____ cents.	1,180	LF	\$ _____	\$ _____
203.1	Common Excavation (outside field) _____ dollars and _____ cents.	525	CY	\$ _____	\$ _____
209.1	Common Fill (3" minus) _____ dollars and _____ cents.	1,400	CY	\$ _____	\$ _____
209.1	Common Fill (6" minus) _____ dollars and _____ cents.	750	CY	\$ _____	\$ _____
214.81	Initial Grade (playing field) _____ dollars and _____ cents.	9,900	SY	\$ _____	\$ _____
C	4" Perforated Underdrain _____ dollars and _____ cents.	954	LF	\$ _____	\$ _____
304.201	Underdrain crushed stone envelope _____ dollars and _____ cents.	93	CY	\$ _____	\$ _____
304.4	Crushed Stone _____ dollars and _____ cents.	1,666	CY	\$ _____	\$ _____

**HUDSON RF 23  
FREEDOM FIELD  
HUDSON, NEW HAMPSHIRE  
BID FORM**

Notes:

1. All prices must be written in ink. Unit prices must be written in words as well as figures for the entire proposal. In case of discrepancy, the amount in words shall govern.
2. All prices given shall include items delineated in the Measurement and Payment Section, and in accordance with the Drawings, Specifications and Contract Documents.

Item No.	Description	Quantity	Unit	Unit Price	Total Price
593.421	Geotextile (non Woven) _____dollars and _____cents.	18,525	SY	\$ _____	\$ _____
607.414	Post Assemblies for Chainlink Fence, 4' high _____dollars and _____cents.	130	U	\$ _____	\$ _____
607.934	Reset Chain Link Fence with Vinyl Coated Fabric, 4' high _____dollars and _____cents.	1,180	LF	\$ _____	\$ _____
641	Loam _____dollars and _____cents.	2,221	CY	\$ _____	\$ _____
645.531	Silt Fence _____dollars and _____cents.	400	LF	\$ _____	\$ _____
646.31A	Hydroseed with Mulch and Tackfiers _____dollars and _____cents.	122,000	SF	\$ _____	\$ _____
692	Mobilization _____dollars and _____cents.	1	U	\$ _____	\$ _____
A	Irrigation System for Soccer Field (365' x230') _____dollars and _____cents.	1	U	\$ _____	\$ _____

**HUDSON RF 23  
FREEDOM FIELD  
HUDSON, NEW HAMPSHIRE  
BID FORM**

Notes:

1. All prices must be written in ink. Unit prices must be written in words as well as figures for the entire proposal. In case of discrepancy, the amount in words shall govern.
2. All prices given shall include items delineated in the Measurement and Payment Section, and in accordance with the Drawings, Specifications and Contract Documents.

Item No.	Description	Quantity	Unit	Unit Price	Total Price
B	Related Shed/Electrical Box / Water Connection _____dollars and _____ cents.	3	U	\$ _____	\$ _____
	<b>TOTAL BID:</b> _____dollars and _____ cents.			\$ _____	\$ _____



**GENERAL CONDITIONS OF THE  
CONTRACT FOR CONSTRUCTION**

**CONSTRUCTION SERVICES FOR  
FREEDOM FIELD REHABILITATION**

**Hudson, NH**

**MARCH 2023**



**Prepared by:**

**Engineering Department  
12 School Street  
Hudson, NH 03051**





# General Conditions

## Table of Contents

	<u>Page</u>
ARTICLE 1 – DEFINITIONS.....	1
1.1    General.....	1
ARTICLE 2 - PRELIMINARY MATTERS .....	5
2.1    Delivery of Bonds and Evidence of Insurance .....	5
2.2    Hazardous Materials .....	6
2.3    Commencement of Contract Times .....	7
2.4    Before Construction Begins.....	7
ARTICLE 3 - CONTRACT DOCUMENTS.....	8
3.1    Intent of Contract .....	8
ARTICLE 4 - SUSPENSION OF WORK.....	9
4.1    Municipalities May Suspend Work .....	9
ARTICLE 5 - CHANGES IN THE WORK .....	9
5.1    Differing Site Conditions.....	9
5.2    Extra Work.....	10
5.3    Changes in Character of Work.....	10
ARTICLE 6 - SCOPE OF WORK.....	11
6.1    Maintenance of Traffic .....	11
6.2    Contractor's Responsibilities.....	11
6.3    Supervision of Work.....	12
6.4    Labor .....	13
6.5    Services, Materials, and Equipment.....	13
6.6    Schedule of Work .....	14
6.7    Substitutes and “Or - Equals” .....	14
6.8    Concerning Subcontractors, Suppliers, and Others .....	16
6.9    Patent Fees and Royalties .....	17
6.10   Permits .....	18
6.11   Laws and Regulations.....	18

	<u>Page</u>
6.12 Taxes.....	19
6.13 Use of Site and Other Areas.....	19
6.14 Record Documents.....	20
6.15 Safety .....	20
6.16 Safety Representative.....	21
6.17 Hazard Communication Programs.....	21
6.18 Emergencies.....	21
6.19 Shop Drawings and Samples .....	21
6.20 Continuing the Work.....	23
6.21 General Warranty and Guarantee.....	23
6.22 Indemnification.....	24
6.23 Layout of the Work.....	25
ARTICLE 7 - CONTROL OF THE WORK .....	25
7.1 Authority of the Engineer .....	25
7.2 Visits to Site.....	26
7.3 Authorized Variations in Work.....	26
7.4 Interpretation of Contract Documents and Acceptability of Work.....	27
7.5 Engineer's Authority and Responsibilities .....	27
ARTICLE 8 - TESTS AND INSPECTIONS .....	28
8.1 Defects .....	28
8.2 Access to Work.....	28
8.3 Tests and Inspections .....	28
8.4 Quality Assurance/Quality Control.....	29
8.5 Uncovering Work.....	30
8.6 Municipality Right to Stop Work .....	31
8.7 Correction or Removal of Defective Work.....	31
8.8 Correction Period.....	31
8.9 Acceptance of Defective Work.....	32
8.10 Municipalities Right to Correct Defective Work.....	32

	<u>Page</u>
ARTICLE 9 - PAYMENTS TO CONTRACTOR AND COMPLETION.....	33
9.1 Measurement and Payment.....	33
9.1.1 Measure of Quantities.....	33
9.1.2 Scope of Payment.....	35
9.1.3 Compensation for Altered Quantities.....	36
9.1.4 Differing Site Conditions, Changes, Extra Work, and Force Account Work.....	36
9.2 Schedule of Values and Partial Payment Applications.....	43
9.3 Payment to the Contractor.....	45
9.4 Reduction in Payments.....	45
9.5 Payment for Alterations to the Contract.....	46
9.6 Unjustified Withholding of Payment.....	47
9.7 Written Notice to Contractor.....	47
9.8 Contractor Representations.....	47
9.9 Substantial Completion.....	47
9.10 Final Inspection.....	48
9.11 Final Payment.....	48
9.12 Progress Payments.....	48
9.13 Acceptance of Work by Engineer.....	49
9.14 Adjustments to Final Payment.....	49
ARTICLE 10 – MISCELLANEOUS.....	50
10.1 Written Notice.....	50
10.2 Cumulative Remedies.....	50
10.3 Survival Obligations.....	50
10.4 Controlling Law.....	50
10.5 Project Visitation by Third Party.....	50



## ARTICLE 1 – DEFINITIONS

### 1.1 GENERAL

The most recent date of issue of publications referenced by the contract documents, including interim publications, that precedes the date of receipt of bid for the Project shall apply unless stated otherwise in the contract documents.

**1.1.1 Acceptance.** The formal written acceptance by the Municipalities of the contract work as described herein which has been completed in all respects in accordance with the Plans and Specifications and any modifications previously approved.

**1.1.2 Addendum (addenda).** Contract revisions developed after advertisement and before opening Bids.

**1.1.3 Advertisement.** A public announcement, inviting Bids for work to be performed or materials to be furnished.

**1.1.4 Agreement.** The written instrument which is evidence of the agreement between the Municipalities and Contractor.

**1.1.5 Approved Material.** 1. Material obtained from within the limits of the Project or from outside sources suitable for the intended use and approved by the Engineer. 2. Manufactured material approved by the Engineer for use in the work.

**1.1.6 Award** The acceptance of a proposal by the Municipalities.

**1.1.7 Bid.** The offer of a Bidder submitted on the prescribed form setting forth the prices for the Work to be performed.

**1.1.8 Bid Bond.** A proposal guarantee as outlined in the Instructions to Bidders for Contracts.

**1.1.9 Bidder.** The individual, partnership, firm, corporation, or any combination thereof, or joint venture, submitting a Bid in accordance with the bidding requirements.

**1.1.10 Bidding Requirements.** The advertisement or invitation to Bid, instructions to Bidders, bid security of acceptable form, if any, and the Bid Form with any supplements.

**1.1.11 Change Order.** A document recommended by the Engineer, signed by the Contractor and Municipalities authorizing changes in the plans or quantities or both, within the scope of the Contract, and establishing the basis of payment and time adjustments for the Work affected by the changes.

**1.1.12 Completion.** Completion of the Project occurs when the Contractor has completed all work required by the Contract and has satisfactorily executed and delivered

to the Engineer all documents, certificates and proofs of compliance required by the Contract.

**1.1.13 Construction Zone.** The area shown on the plans in which the contract work is to be performed.

**1.1.14 Contract.** The written agreement between the Municipalities and the Contractor setting forth the obligations of the parties there under, including, but not limited to the performance of the Work and the basis of payment.

**1.1.15 Contract Bonds:** The approved form of security including a Performance Bond and a Labor and Materials Payment Bond executed by the Contractor and his Surety or Sureties, guaranteeing complete execution of the Contract and all supplemental agreements pertaining thereto, including the payment of all legal debts pertaining to the construction of the project.

**1.1.16 Contract Documents.** Those items so designated in the Agreement. Including but not limited to information supplied to bidders, bid, bid bond, Agreement, payment bond, performance bond, notice of award, notice to proceed, change orders, drawings, specifications and addenda.

**1.1.17 Contract Administrator/Project Engineer.** The field representative of the Engineer having direct supervision of the administration of the Contract.

**1.1.18 Contract Price.** Those monies payable to the Contractor pursuant to the Contract terms for completion of the Work as stated in the Agreement.

**1.1.19 Contract Time.** The time allowed for completion of the contract, including authorized time extensions.

**1.1.20 Contractor/Prime Contractor.** The individual or entity with whom the Municipalities has entered into Agreement.

**1.1.21 Day.** Unless otherwise indicated, this term will mean a calendar day.

**1.1.22 Delay.** Any event, action, force, or factor that causes the established Contract Time to be exceeded for performance of the Contract.

**1.1.23 Department/Municipalities/Owner.** The Municipalities designated as the party of the first part to the Contract .

**1.1.24 Differing Site Conditions.** Subsurface or latent physical conditions that, (1) differ materially from those indicated in the Contract, or (2) differ materially from conditions normally encountered or those conditions generally recognized as inherent in the nature of the Work required in the Contract, or (3) are unknown conditions of an unusual nature.

**1.1.25 Engineer.** The New Hampshire licensed Engineering Firm or Engineer with whom the Municipalities has contracted, who is responsible for engineering supervision of the work, acting directly or through his duly authorized representatives.

**1.1.26 Expression.** By or to the Engineer. In order to avoid cumbersome and confusing repetition of expressions in these specifications, it is hereby provided that any and all of the following words or any form of such words, unless clearly indicated otherwise, shall be understood to be followed by the words “by the Engineer” or “to the Engineer”: Accepted, approved, authorized, condemned, considered, or deemed necessary, contemplated, designated, determined, directed, disapproved, established, given, indicated, insufficient, ordered, permitted, rejected, required, reserved, satisfactory, specified, sufficient, suitable, suspended, unacceptable or unsatisfactory.

**1.1.27 Extra Work.** Work performed by the Contractor not originally specified in the Contract, but found essential to the satisfactory completion of the project.

**1.1.28 Force Account.** A basis of payment for the directed performance of Work with payment based on the actual cost for labor, materials, and equipment with consideration for overhead and profit.

**1.1.29 Hazardous Material (toxic waste).** Shall mean material as defined by RSA 147-A.

**1.1.30 Major and Minor Contract Items.** Any contract item having an original value in excess of five percent of the original Contract total for contracts of \$1,000,000.00 or less, or three percent of the original Contract total for contracts greater than \$1,000,000.00 shall be considered as a major item or items. All other contract items are considered as minor.

**1.1.31 Notice to Proceed.** Written notice to the Contractor to proceed with the Contract work, including the beginning of Contract time when applicable.

**1.1.32 Project.** The specific section(s) of the Municipal facilities together with all appurtenances to be constructed under the Contract.

**1.1.33 Proposal Form.** The prescribed form on which the Municipalities requires the Bid be submitted.

**1.1.34 Prosecution of Work.** A document included in the Contract which gives the Contractor specific requirements and information unique to the Project, allowing for the satisfactory performance of the Work. It also includes the final and any intermediate completion dates.

**1.1.35 Qualified Products List (QPL).** A list of products prequalified by the Engineer as meeting the Contract requirements for specified materials to be incorporated into the Work. The list is maintained and updated yearly by the NHDOT Bureau of Materials and Research.

- 1.1.36 Site.** The Project area provided to perform the Work.
- 1.1.37 Solid Waste.** Shall mean material as defined by RSA 149-M.
- 1.1.38 Special Attentions.** Notices calling bidders' attention to issues applicable to an individual project.
- 1.1.39 Special Provisions.** Additions and revisions to the Standard and Supplemental Specifications applicable to an individual project.
- 1.1.40 Specifications.** The compilation of Standard Specifications (including these Municipal General Conditions), Supplemental Specifications, Special Provisions, Special Attentions and other requirements for the performance of prescribed work.
- 1.1.41 Specified Completion Date.** The date on which the Contract work is specified to be completed.
- 1.1.42 Storm Water Pollution Prevention Plan, (SWPPP).** Per Environmental Protection Agency requirements.
- 1.1.43 Subcontractor.** An individual, partnership, firm, corporation, or any combination thereof, or joint venture, to which the Contractor sublets any part of the Contract.
- 1.1.44 Subsidiary and Subsidiary Item.** These terms are used to indicate work for which no direct payment will be made. Such work is considered to be incidental to items having contract prices, and the bid prices submitted by the Contractor shall be sufficient to absorb the cost of all work designated as subsidiary or as subsidiary items.
- 1.1.45 Superintendent.** The Contractor's authorized representative in responsible charge of the work.
- 1.1.46 Supplementary Agreement.** A written agreement recommended by the Engineer, between the Contractor and the Municipalities, for the performance of work by the Contractor at agreed prices under items not originally included in the Contract.
- 1.1.47 Surety.** The corporation, partnership, or individual, other than the Contractor, executing a bond furnished by the Contractor.
- 1.1.48 Traffic Control Plan (TCP).** A document included in the Contract which gives the Contractor specific requirements and procedures for controlling traffic during the course of construction. It also allows the Contractor to submit for approval variations of such plan.
- 1.1.49 Wetland.** "An area that is inundated or saturated by surface or ground water at a frequency and duration sufficient to support and that under normal conditions does support, a prevalence of vegetation typically adapted for life in saturated soil conditions.



Wetlands include, but are not limited to swamps, marshes, bogs, and similar areas.” (NH Code of Administrative Rules, Chapter Wt 101.87, 1997)

**1.1.50 Work.** The furnishing of all labor, materials, equipment, and incidentals necessary or convenient to the successful completion of the Project, and the carrying out of the duties and obligations imposed by the Contract.

**1.1.51 Working Drawings.** Temporary bridge plans, cofferdam plans, water diversion structure plans, plans of precast elements to be designed by the Contractor, shop fabrication drawings, erection plans, falsework plans, temporary support systems, bending diagrams when required for reinforcing steel, scaffolding plans and bridge analysis, detour plans, sign structure plans, traffic signal poles and mast arm plans, Storm water Pollution Prevention Plan (SWPPP), erosion control plans, or any other supplementary plans or similar data required of the Contractor to control the Work and its prosecution.

## **ARTICLE 2 - PRELIMINARY MATTERS**

### **2.1 DELIVERY OF BONDS AND EVIDENCE OF INSURANCE**

**2.1.1** Concurrent with the execution of the Construction Contract, Contractor shall deliver to the Municipality such bonds as may be required by the Contract. Performance and Labor and Material Payment Bonds will be provided, unless specifically deleted by the Invitation for Bids.

**2.1.2** Prior to the start of Work, the Contractor shall deliver to the Municipality proof of insurance as required under the Contract including but not limited to certificates of insurance naming the Municipality and its agents/consultants as additional insureds.

**2.1.3** The Contractor shall indemnify, defend and save-harmless the Municipality and their officers, agents, and employees from and against any and all claims, liabilities, suits or penalties arising out of (or which may be claimed to arise out of) negligent acts or omissions of the Contractor or Subcontractors in the performance of Work covered by the Contract. This responsibility shall survive the termination of the Contract. Notwithstanding the foregoing, nothing herein contained shall be deemed to constitute a waiver of the sovereign immunity of the Municipality, which immunity is hereby reserved by the Municipality.

**2.1.4** Liability insurance for damages imposed by law of the kinds and amounts specified herein shall be obtained and maintained by the Contractor. The insurance obtained shall cover all operations under the Contract whether performed by the Contractor or Subcontractor of any tier and shall be maintained until Acceptance.

**2.1.5** Each policy shall contain a clause prohibiting cancellation or modifications of the policy earlier than 30 days, or 10 days in cases of non-payment of premium, after written notice thereof has been received by the Municipality.

**2.1.6** All insurance requirements shall be the responsibility of the Contractor. The Contractor shall require Subcontractors to maintain similar coverage.

**2.1.7** It is specifically agreed between the parties executing this Contract that it is not intended by the Contract provisions to make the public or any member thereof a third party beneficiary hereunder, or to authorize anyone not a party to the Contract to maintain a suit for personal injuries or property damage pursuant to the terms or provisions of the Contract. The duties, obligations, and responsibilities of the parties to this Contract with respect to third parties shall remain as imposed by law.

**2.1.8** Insurance coverage shall be consistent with limits outlined in Subsection 107.11 of the NHDOT Standard Specifications for Road and Bridge Construction.

## **2.2 HAZARDOUS MATERIALS**

**2.2.1** . The Contractor shall also be aware of laws and regulations relating to hazardous materials which may be encountered during construction operations, either within project limits or at material sites off the project. The health and safety of employees, the general public, and the potential of damage to the overall environment is possible if hazardous materials are not recognized, reported, and the appropriate action taken to dispose of, remove from the site, or otherwise contain the possible contaminants.

**2.2.2** State laws such as RSA 141-E, Asbestos Management and Control RSA 147-A, Hazardous Waste Management, and RSA 149-M, Solid Waste Management identify the major areas of concern. Parts Env-Wm 100-110, Env-Wm 101-300, 2100-3700, and Env-Wm 3900 of the New Hampshire Code of Administrative Rules identify various contaminants related to hazardous waste, solid waste, solid waste and asbestos and their management, respectively.

**2.2.3** If any abnormal condition is encountered or exposed that indicates the presence of a hazardous material or toxic waste, construction operations shall be immediately suspended in the area and the Engineer notified. No further work shall be conducted in the area of the contaminated material until the site has been investigated and the Municipalities have given approval to continue the work in the area. The Contractor shall fully cooperate with the Engineer and perform any remedial work as directed. Work shall continue in other areas of the Project unless otherwise directed.

**2.2.4** Exposure to hazardous materials may result from contact with, but not necessarily limited to, such items as drums, barrels, other containers, waste such as cars, batteries, and building construction debris. Containers leaking unknown chemicals or liquids, abandoned cars leaking petroleum products, batteries leaking acid, construction debris which may include asbestos, or any other source of suspected hazardous material found within excavation areas or stockpiled on land within construction limits shall be referred to the Department of Environmental Services so that a proper identification of the materials may be made and disposal procedures initiated as required.

**2.2.5** Disposition of the hazardous material or toxic waste shall be made under the requirements and regulations of the Department of Environmental Services. Work required to dispose of these materials shall be performed under a Supplemental Agreement or Contract item, if included in Contract. If the waste material disposal requires special procedures, the Municipalities will make arrangements to dispose of the material, either by the Contractor or by other parties.

## **2.3 COMMENCEMENT OF CONTRACT TIMES**

**2.3.1 Execution and Approval of Contract.** The signed Contract, together with the Contract Bond, certificate of insurance and the Disadvantaged Business Enterprise forms, if required, shall be returned to the Municipalities within 10 days after the date of notice that the Proposal has been accepted. The Contract will not be considered approved until it has been fully executed by all of the parties to the Contract.

**2.3.2 Failure to Execute Contract.** If the successful bidder fails to execute the Contract and file acceptable bond within 5 days after the date of notice of acceptance of the Proposal, the Municipalities may cancel the notice of award and retain the bidder's Proposal Guarantee which shall become the property of the Municipalities, not as a penalty, but in liquidation of damages sustained. Contract award may then be made to the next lowest responsible bidder or the Work may be readvertised.

**2.3.3 Contract Time/Notice to Proceed.** The Contract Times will commence to run on the thirtieth day after the Effective Date of the Agreement or, if a Notice to Proceed is given, on the day indicated in the Notice to Proceed. A Notice to Proceed may be given at any time within 30 days after the Effective Date of the Agreement. In no event will the Contract Times commence to run later than the 90<sup>th</sup> day after the day of Bid opening or the thirtieth day after the Effective Date of the Agreement, whichever date is earlier.

**2.3.4 Starting the Work.** Contractor shall start to perform the Work on the date when the Contract Times commence to run. No Work shall be done at the Site prior to the date on which the Contract Times commence to run.

## **2.4 BEFORE CONSTRUCTION BEGINS**

**2.4.1** Before undertaking each part of the Work, Contractor shall carefully study and compare the Contract Documents and check and verify pertinent figures therein and all applicable field measurements. Contractor shall promptly report in writing to Engineer any conflict, error, ambiguity, or discrepancy which Contractor may discover and shall obtain a written interpretation or clarification from Engineer before proceeding with any Work affected thereby.

**2.4.2** Contractor shall provide for all additional lands and access thereto that may be required for temporary construction facilities or storage of materials and equipment.

**2.4.3** A preconstruction conference shall be held by the Contractor prior to the Work commencing. At this time the Contractor shall submit to the Engineer and Municipalities

for approval a Progress Schedule outlining the intended schedule of the Work. All parties of interest including but not limited to utilities, Municipal officials, sub-contractors, etc. shall be invited to attend.

### **ARTICLE 3 - CONTRACT DOCUMENTS**

#### **3.1 INTENT OF CONTRACT**

**3.1.1** The intent of the Contract is to provide for the construction and completion in every detail of the work it describes. The Contractor shall furnish all labor, materials, equipment, tools, transportation, and supplies required to complete the Work under the Contract.

**3.1.2** Clarifications and/or interpretations of the Contract Documents shall be at the discretion of the Engineer. All requests by Contractor for same shall be made in writing to the Engineer.

**3.1.3** The Specifications, Supplemental Specifications, Plans, Special Provisions, other special Contract requirements and all supplemental documents are essential parts of the Contract and a requirement occurring in one is as binding as though occurring in all. They are intended to be complementary and to describe and provide for a complete Contract. In case of discrepancy between these Contract documents, calculated dimensions, unless obviously incorrect, will govern over scaled dimensions and the parts of the Contract will prevail in the following descending order:

Municipal General Conditions; Special Contract Requirements; Special Provisions; Plans; Supplemental Specifications; Standard Specifications including Standard Details, Standard Plans; Including, but not limited to, Special Attentions in the mentioned descending order.

**3.1.4** To the extent applicable no Local, State or Federal code and/or regulation will be deemed waived as a result of the conditions and /or specifications contained herein.

**3.1.5** Conflicts between the requirements of these General Conditions and specifications incorporated herein including but not limited to the NHDOT Standard Specifications for Road and Bridge Construction as it may be amended shall be interpreted to the benefit of the Municipalities at its sole discretion unless the Contractor notifies Municipalities of said conflict prior to submission of bids. If notified in writing of a conflict in specifications prior to bid the Municipalities shall take such action as it deems appropriate.

## **ARTICLE 4 - SUSPENSION OF WORK**

### **4.1 MUNICIPALITIES MAY SUSPEND WORK**

**4.1.1** Municipalities may suspend all or any portion of the Work for any reason during performance of the Contract. Suspension of all or any portion of the Work will be done by written notice to the Contractor.

**4.1.1.1** If the suspension or delay resulting from the written order is considered unreasonable, or not customary, or inherent to the construction industry; the Contractor shall submit a written request providing the reasons and justification for any Contract adjustment considered necessary as a result of the suspension or delay. The written request for Contract adjustment must be submitted to the Engineer in writing within seven days following receipt of the notice to resume work. A Contract adjustment will not be made unless the request for adjustment has been submitted within the prescribed time.

**4.1.1.2** There will be no Contract adjustment under the provisions of this Subsection if the Work would have been suspended or delayed by any other cause, or for which an adjustment is provided for, or excluded under any other term or condition of the Contract.

**4.1.1.3** The request for a Contract adjustment will be reviewed by the Engineer. If there is agreement that, (1) there has been an increase in the Contract performance cost or time as a result of such suspension and (2) the suspension was caused by conditions beyond the control of and not the fault of the Contractor, Contract suppliers, or subcontractors at any approved tier; and not caused by weather, an adjustment will be made to the Contract by Change Order.

## **ARTICLE 5 - CHANGES IN THE WORK**

### **5.1 DIFFERING SITE CONDITIONS**

**5.1.1** If differing site conditions are encountered at the work site, the Contractor shall promptly notify the Municipalities and Engineer in writing. No further disturbance of the site or performance of the affected work is to be done after the alleged differing site conditions are noted unless directed otherwise in writing by the Engineer. If the Municipalities and Engineer determine the conditions materially differ and cause an increase or decrease in the cost or time required for the performance of any work under the Contract, an adjustment, excluding loss of anticipated profits, will be made and the Contract modified in writing accordingly. The Engineer will notify the Contractor whether or not an adjustment in the Contract is warranted.

**5.1.2** After receipt of written notice as required by paragraph 5.1.1, Engineer will promptly review the pertinent condition, determine the necessity of obtaining additional exploration or tests with respect thereto, and advise Municipalities in writing (with a copy to Contractor) of Engineer's findings and conclusions.

## **5.2 EXTRA WORK**

**5.2.1** Extra Work shall be performed by the Contractor in accordance with the Specifications and as directed, and will be paid for as provided herein. When the Contract provides for payment of certain work under Extra Work, no further order from the Engineer will be necessary for such work; otherwise, when the Engineer determines that Extra Work is to be performed, an Extra Work Order will be issued.

**5.2.2** The Contract Price or the Contract Times, or both, may be equitably adjusted to the extent that the existence of such differing subsurface or physical condition causes an increase or decrease in Contractor's cost of, or time required for, performance of the Work. Contractor shall not be entitled to any adjustment in the Contract Price or Contract Times if:

**5.2.2.1** Contractor knew or should have known of the existence of such conditions at the time Contractor made a final commitment to Municipalities respect of Contract Price and Contract Times by the submission of a Bid or becoming bound under a negotiated contract; or

**5.2.2.2** The existence of such condition could reasonably have been discovered or revealed as a result of any examination, investigation, exploration, test, or study of the Site and contiguous areas required by the Bidding Requirements or Contract Documents to be conducted by or for Contractor prior to Contractor's making such final commitment; or

**5.2.2.3** Contractor failed to give prompt written notice as required by paragraph 5.1.

**5.2.3** If Municipalities and Contractor are unable to agree on entitlement to or on the amount or extent, if any, of any adjustment in the Contract Price or Contract Times, or both, a Claim may be made therefore as provided herein. However, Municipalities, Engineer, and Engineer's Consultants shall not be liable to Contractor for any claims, costs, losses, or damages (including but not limited to all fees and charges of engineers, architects, attorneys, and other professionals and all court or arbitration or other dispute resolution costs) sustained by Contractor on or in connection with any other project or anticipated project.

## **5.3 CHANGES IN CHARACTER OF WORK**

**5.3.1** The Engineer reserves the right to provide written notice to the Contractor at any time during the Contract to change Major Item quantities or make other alterations considered necessary to satisfactorily complete the Contract.

**5.3.2** Such changes in quantities and alterations do not invalidate the Contract nor release the Contract Surety.

**5.3.3** If the directed changes require additional time to complete the Contract, adjustments in the Contract Time shall be determined by the Engineer.

**5.3.4** Payments for the alterations in the Work or changed Major Item quantities will be made as provided under Article 9.

**5.3.5** The basis of the Contract adjustment shall be agreed upon before the performance of the Work. If a basis cannot be agreed upon, prosecution of the Work may be ordered by the Municipalities under the Force Account provisions of Subsection 9.4.3.3.

## **ARTICLE 6 - SCOPE OF WORK**

### **6.1 MAINTENANCE OF TRAFFIC**

**6.1.1** The Contractor shall keep all roads open to all traffic during construction. The Contractor shall keep the signals operational during construction. Where provided in the Contract, or approved by the Engineer, traffic may be bypassed over an approved detour route. In the event a Contractor proposes to construct detours not shown on the Plans, the Contractor shall submit proposed detour plans for documentation, showing the proposed location, alignment, grade, cross section, and signing. All detours shall be kept in a safe and adequate condition. The Contractor shall furnish, erect, and maintain barricades, warning signs, delineators, striping, flaggers, and pilot cars in accordance with the MUTCD and Sections 618, 619 and 632 of the New Hampshire Department of Transportation Standard Specifications for Road and Bridge Construction. The Contractor shall bear all expense of maintaining the section of road undergoing improvement including all temporary approaches or crossings and intersections with trails, roads, streets, abutters, and other features as may be necessary. Payment for the furnishing, installation, and maintenance of traffic control will be as provided in the Agreement. No other additional compensation for maintenance will be made.

**6.1.2** The Contractor shall make passable and open to traffic the sections of the project and temporary roadways as agreed upon between the Contractor and the Engineer for the accommodation of necessary traffic during the anticipated period of suspension. During this suspension period the maintenance of the temporary roadway and sections of the Project will be the responsibility of the Contractor.

**6.1.3** When Work is suspended due to seasonal or climatic conditions or, for failure to correct conditions unsafe for the workers or the general public, for failure to carry out orders of the Engineer or for other reasons caused by the Contractor, all costs for maintenance of the roadway to accommodate traffic during the suspended period shall be borne by the Contractor.

### **6.2 CONTRACTOR'S RESPONSIBILITIES**

**6.2.1** Until Acceptance of the project by the Engineer, the Contractor is responsible for and shall protect the Work against injury or damage from all causes whether arising from the execution or the nonexecution of the Work except as provided herein.

**6.2.2** The Contractor, at his or her expense, shall rebuild, repair, restore, and make good all losses, injuries, or damage to any portion of the Work from any cause before Acceptance, except for loss, injury or damage due to causes not under the control and without the fault or negligence of the Contractor. Such causes include, but are not restricted to, natural disasters such as earthquake, tidal wave, tornado, hurricane, or other cataclysmic phenomenon of nature; acts of a public enemy; acts of governmental authorities; and errant vehicles. The Contractor shall repair damage due to such excepted causes and shall be paid at the contract prices or in the same manner as Extra Work as determined and ordered by the Engineer. Causes under the control of the Contractor shall be any cause that he or she could have prevented by reasonable and foreseeable action and shall include damage caused by normal weather conditions.

**6.2.3** In case of suspension of the Work from any cause, the Contractor is responsible for the Work under the Contract and shall prevent damage to the project, provide for normal drainage, and erect necessary temporary structures, signs, or other facilities. The Contractor shall also maintain in an acceptable growing condition all living material in newly established plantings, seedings, and soddings furnished under the Contract, and protect new tree growth and other designated vegetative growth against injury. When work is suspended for reasons of differing site conditions, the costs during the period of suspension shall be borne by the Contractor.

**6.2.4** The Contractor shall comply with all Federal, State, and local laws and regulations controlling pollution of the environment. Pollution of streams, lakes, ponds and reservoirs with fuels, oils, bitumens, chemicals, or other harmful materials and pollution of the atmosphere from particulate and gaseous matter shall be avoided to the extent practicable.

**6.2.5** Work performed and materials furnished shall be uniform in character and meet the Contract dimensions and material requirements according to tolerances specified in the Contract. If tolerances are specified, deviations beyond the specified limits will be unacceptable. When tolerance limits are not specified, and only single dimensions are indicated, such dimensions are to be regarded as nominal dimensions. If the materials furnished, work performed, or the finished product does not conform to the Contract, but adequately addresses the design purpose, the Engineer will determine the conditions under which the Work will be accepted and allowed to remain in place unless there are other provisions in the Contract that provide for this determination. Where this determination is made by the Engineer rather than Contract provisions, the Engineer will document the basis of acceptance by Contract modification. The modification will provide for an appropriate adjustment in the Contract price for such work or materials as necessary to support the Engineer's determination.

### **6.3 SUPERVISION OF WORK**

**6.3.1** Contractor shall supervise, inspect, and direct the Work competently and efficiently, devoting such attention thereto and applying such skills and expertise as may be necessary to perform the Work in accordance with the Contract Documents. Contractor



shall be solely responsible for the means, methods, techniques, sequences, and procedures of construction, but Contractor shall not be responsible for the negligence of Municipalities or Engineer in the design or specification of a specific means, method, technique, sequence, or procedure of construction which is shown or indicated in and expressly required by the Contract Documents. Contractor shall be responsible to see that the completed Work complies accurately with the Contract Documents.

**6.3.2** At all times during the progress of the Work, Contractor shall assign a competent resident superintendent thereto who shall not be replaced without written notice to Municipalities and Engineer except under extraordinary circumstances. The superintendent will be Contractor's representative at the Site and shall have authority to act on behalf of Contractor. All communications given to or received from the superintendent shall be binding on Contractor.

## **6.4 LABOR**

**6.4.1** Contractor shall provide competent, suitably qualified personnel to survey, layout, and construct the Work as required by the Contract Documents. Contractor shall at all times maintain good discipline and order at the Site.

**6.4.2** Except as otherwise required for the safety or protection of persons or the Work or property at the Site or adjacent thereto, and except as otherwise stated in the Contract Documents, all Work at the Site shall be performed during regular working hours, and Contractor will not permit overtime work or the performance of Work on Saturday, Sunday, or any legal holiday without Municipalities' written consent (which will not be unreasonably withheld) given after prior written notice to Engineer.

## **6.5 SERVICES, MATERIALS, AND EQUIPMENT**

**6.5.1** Unless otherwise specified in the General Requirements, Contractor shall provide and assume full responsibility for all services, materials, equipment, labor, transportation, construction equipment and machinery, tools, appliances, fuel, power, light, heat, telephone, water, sanitary facilities, temporary facilities, and all other facilities and incidentals necessary for the performance, testing, start-up, and completion of the Work.

**6.5.2** All materials and equipment incorporated into the Work shall be as specified or, if not specified, shall be of good quality and new, except as otherwise provided in the Contract Documents. All warranties and guarantees specifically called for by the Specifications shall expressly run to the benefit of Municipalities. If required by Engineer, Contractor shall furnish satisfactory evidence (including reports of required tests) as to the source, kind, and quality of materials and equipment. All materials and equipment shall be stored, applied, installed, connected, erected, protected, used, cleaned, and conditioned in accordance with instructions of the applicable Supplier, except as otherwise may be provided in the Contract Documents.

## 6.6 SCHEDULE OF WORK

**6.6.1** Contractor shall adhere to the progress schedule established in accordance with Article 2.4.3 as it may be adjusted from time to time as provided below.

**6.6.1.1** Contractor shall submit to Engineer for acceptance proposed adjustments in the progress schedule that will not result in changing the Contract Times (or Milestones). Such adjustments will conform generally to the progress schedule then in effect and additionally will comply with any provisions of the General Requirements applicable thereto.

**6.6.1.2** Proposed adjustments in the progress schedule that will change the Contract Times (or Milestones) shall be submitted in accordance with the requirements of Article 2. Such adjustments may only be made upon written approval of the Engineer.

## 6.7 SUBSTITUTES AND "OR - EQUALS"

**6.7.1** Whenever an item of material or equipment is specified or described in the Contract Documents by using the name of a proprietary item or the name of a particular Supplier, the specification or description is intended to establish the type, function, appearance, and quality required. Unless the specification or description contains or is followed by words reading that no like, equivalent, or "or-equal" item or no substitution is permitted, other items of material or equipment or material or equipment of other Suppliers may be submitted to Engineer for review under the circumstances described below.

**6.7.1.1** "Or – Equals": If in Engineer's sole discretion an item of material or equipment proposed by Contractor is functionally equal to that named and sufficiently similar so that no change in related Work will be required, it may be considered by Engineer as an "or-equal" item, in which case review and approval of the proposed item may, in Engineer's sole discretion, be accomplished without compliance with some or all of the requirements for approval of proposed substitute items. For the purposes of this paragraph, a proposed item of material or equipment will be considered functionally equal to an item so named if:

**6.7.1.1(a)** in the exercise of reasonable judgment the Engineer determines that: (i) it is at least equal in quality, durability, appearance, strength, availability, and design characteristics; (ii) it will reliably perform at least equally well the function imposed by the design concept of the completed Project as a functioning whole; (iii) it has a proven performance record; and

**6.7.1.1(b)** Contractor certifies that: (i) there is no increase in cost to the Municipalities or increase in Contract Times; and (ii) it will conform substantially, even with deviations, to the detailed requirements of the item named in the Contract Documents.

#### **6.7.1.2 Substitute Items:**

**6.7.1.2(a)** If in Engineer's sole discretion an item of material or equipment proposed by Contractor does not qualify as an "or-equal" item under paragraph 6.7.1, it will be considered a proposed substitute item.

**6.7.1.2(b)** Contractor shall submit sufficient information as provided below to allow Engineer to determine that the item of material or equipment proposed is essentially equivalent to that named and an acceptable substitute therefore. Requests for review of proposed substitute items of material or equipment will not be accepted by Engineer from anyone other than Contractor.

**6.7.1.2(c)** The procedure for review by Engineer will be as set forth in paragraph 6.7.1.2.(d), as supplemented in the General Requirements and as Engineer may decide is appropriate under the circumstances.

**6.7.1.2(d)** Contractor shall first make written application to Engineer for review of a proposed substitute item of material or equipment that Contractor seeks to furnish or use. The application shall certify that the proposed substitute item will perform adequately the functions and achieve the results called for by the general design, be similar in substance to that specified, and be suited to the same use as that specified. The application will state the extent, if any, to which the use of the proposed substitute item will prejudice Contractor's achievement of Substantial Completion on time, whether or not use of the proposed substitute item in the Work will require a change in any of the Contract Documents (or in the provisions of any other direct contract with Municipalities for work on the Project) to adapt the design to the proposed substitute item and whether or not incorporation or use of the proposed substitute item in connection with the Work is subject to payment of any license fee or royalty. All variations of the proposed substitute item from that specified will be identified in the application, and available engineering, sales, maintenance, repair, and replacement services will be indicated. The application will also contain an itemized estimate of all costs or credits that will result directly or indirectly from use of such substitute item, including costs of redesign and claims of other contractors affected by any resulting change, all of which will be considered by Engineer in evaluating the proposed substitute item. Engineer may require Contractor to furnish additional data about the pro-posed substitute item.

**6.7.2** If a specific means, method, technique, sequence, or procedure of construction is shown or indicated in and expressly required by the Contract Documents, Contractor may furnish or utilize a substitute means, method, technique, sequence, or procedure of construction approved by Engineer. Contractor shall submit sufficient information to allow Engineer, in Engineer's sole discretion, to determine that the substitute proposed is

equivalent to that expressly called for by the Contract Documents. The procedure for review by Engineer will be similar to that provided in subparagraph 6.7.1.2(d).

**6.7.3** Engineer will be allowed a reasonable time within which to evaluate each proposal or submittal made pursuant to paragraph 6.7. Engineer will be the sole judge of acceptability. No "or-equal" or substitute will be ordered, installed or utilized until Engineer's review is complete, which will be evidenced by either a Change Order for a substitute or an approved Shop Drawing for an "or equal." Engineer will advise Contractor in writing of any negative determination.

**6.7.4** Special Guarantee: Municipalities may require Contractor to furnish at Contractor's expense a special performance guarantee or other surety with respect to any substitute.

**6.7.5** Engineer's Cost Reimbursement: Engineer will record time required by Engineer and Engineer's Consultants in evaluating substitute proposed or submitted by Contractor pursuant to paragraphs 6.7.1.1 and 6.7.1.2 and in making changes in the Contract Documents (or in the provisions of any other direct contract with Municipalities for work on the Project) occasioned thereby. Whether or not Engineer approves a substitute item so proposed or submitted by Contractor, Contractor may reimburse Municipalities for the charges due Engineer and Engineer's Consultants for evaluating each such proposed substitute.

**6.7.6** Contractor's Expense: Contractor shall provide all data in support of any proposed substitute or "or-equal" at Contractor's expense.

## **6.8** CONCERNING SUBCONTRACTORS, SUPPLIERS, AND OTHERS

**6.8.1** Contractor shall not employ any Subcontractor, Supplier, or other individual or entity, whether initially or as a replacement, against whom Municipalities may have reasonable objection. Contractor shall not be required to employ any Subcontractor, Supplier, or other individual or entity to furnish or perform any of the Work against whom Contractor has reasonable objection.

**6.8.2** If the Supplementary Conditions require the identity of certain Subcontractors, Suppliers, or other individuals or entities to be submitted to Municipalities in advance for acceptance by Municipalities by a specified date prior to the Effective Date of the Agreement, and if Contractor has submitted a list thereof in accordance with the Supplementary Conditions, Municipalities' acceptance (either in writing or by failing to make written objection thereto) by the date indicated for of any such Subcontractor, Supplier, or other individual or entity so identified may be revoked on the basis of reasonable objection after due investigation. Contractor shall submit an acceptable replacement for the rejected Subcontractor, Supplier, or other individual or entity, and the Contract Price will be adjusted by the difference in the cost occasioned by such replacement, and an appropriate Change Order will be issued or Written Amendment signed. No acceptance by Municipalities of any such Subcontractor, Supplier, or other

individual or entity, whether initially or as a replacement, shall constitute a waiver of any right of Municipalities or Engineer to reject defective Work.

**6.8.3** Contractor shall be fully responsible to Municipalities and Engineer for all acts and omissions of the Subcontractors, Suppliers, and other individuals or entities performing or furnishing any of the Work just as Contractor is responsible for Contractor's own acts and omissions. Nothing in the Contract Documents shall create for the benefit of any such Subcontractor, Supplier, or other individual or entity any contractual relationship between Municipalities or Engineer and any such Subcontractor, Supplier or other individual or entity, nor shall it create any obligation on the part of Municipalities or Engineer to pay or to see to the payment of any moneys due any such Subcontractor, Supplier, or other individual or entity except as may otherwise be required by Laws and Regulations.

**6.8.4** Contractor shall be solely responsible for scheduling and coordinating the Work of Subcontractors, Suppliers, and other individuals or entities performing or furnishing any of the Work under a direct or indirect contract with Contractor.

**6.8.5** Contractor shall require all Subcontractors, Suppliers, and such other individuals or entities performing or furnishing any of the Work to communicate with Engineer through Contractor.

**6.8.6** The divisions and sections of the Specifications and the identifications of any Drawings shall not control Contractor in dividing the Work among Subcontractors or Suppliers or delineating the Work to be performed by any specific trade.

**6.8.7** All Work performed for Contractor by a Subcontractor or Supplier will be pursuant to an appropriate agreement between Contractor and the Subcontractor or Supplier which specifically binds the Subcontractor or Supplier to the applicable terms and conditions of the Contract Documents for the benefit of Municipalities and Engineer. Whenever any such agreement is with a Subcontractor or Supplier who is listed as an additional insured on the property insurance required herein, the agreement between the Contractor and the Subcontractor or Supplier will contain provisions whereby the Subcontractor or Supplier waives all rights against Municipalities, Contractor, Engineer, Engineer's Consultants, and all other individuals or entities identified in the Supplementary Conditions to be listed as insureds or additional insureds (and the officers, directors, partners, employees, agents, and other consultants and subcontractors of each and any of them) for all losses and damages caused by, arising out of, relating to, or resulting from any of the perils or causes of loss covered by such policies and any other property insurance applicable to the Work. If the insurers on any such policies require separate waiver forms to be signed by any Subcontractor or Supplier, Contractor will obtain the same.

## **6.9 PATENT FEES AND ROYALTIES**

**6.9.1** Contractor shall pay all license fees and royalties and assume all costs incident to the use in the performance of the Work or the incorporation in the Work of any invention,

design, process, product, or device which is the subject of patent rights or copyrights held by others. If a particular invention, design, process, product, or device is specified in the Contract Documents for use in the performance of the Work and if to the actual knowledge of Municipalities or Engineer its use is subject to patent rights or copyrights calling for the payment of any license fee or royalty to others, the existence of such rights shall be disclosed by Municipalities in the Contract Documents. To the fullest extent permitted by Laws and Regulations, Contractor shall indemnify and hold harmless Municipalities, Engineer, Engineer's Consultants, and the officers, directors, partners, employees or agents, and other consultants of each and any of them from and against all claims, costs, losses, and damages (including but not limited to all fees and charges of engineers, architects, attorneys, and other professionals and all court or arbitration or other dispute resolution costs) arising out of or relating to any infringement of patent rights or copyrights incident to the use in the performance of the Work or resulting from the incorporation in the Work of any invention, design, process, product, or device not specified in the Contract Documents.

## **6.10 PERMITS**

**6.10.1** Unless otherwise provided in the Supplementary Conditions, Contractor shall obtain and pay for all construction permits and licenses. Municipalities shall assist Contractor, when necessary, in obtaining such permits and licenses. Contractor shall pay all governmental charges and inspection fees necessary for the prosecution of the Work which are applicable at the time of opening of Bids, or, if there are no Bids, on the Effective Date of the Agreement. Municipalities shall pay all charges of utility owners for connections providing permanent service to the Work.

## **6.11 LAWS AND REGULATIONS**

**6.11.1** Contractor shall give all notices and comply with all Laws and Regulations applicable to the performance of the Work. Except where otherwise expressly required by applicable Laws and Regulations, neither Municipalities nor Engineer shall be responsible for monitoring Contractor's compliance with any Laws or Regulations.

**6.11.2** If Contractor performs any Work knowing or having reason to know that it is contrary to Laws or Regulations, Contractor shall bear all claims, costs, losses, and damages (including but not limited to all fees and charges of engineers, architects, attorneys, and other professionals and all court or arbitration or other dispute resolution costs) arising out of or relating to such Work; however, it shall not be Contractor's primary responsibility to make certain that the Specifications and Drawings are in accordance with Laws and Regulations, but this shall not relieve Contractor of Contractor's obligations herein.

**6.11.3** Changes in Laws or Regulations not known at the time of opening of Bids (or, on the Effective Date of the Agreement if there were no Bids) having an effect on the cost or time of performance of the Work may be the subject of an adjustment in Contract Price or Contract Times. If Municipalities and Contractor are unable to agree on entitlement to or

on the amount or extent, if any, of any such adjustment, a Claim may be made therefore as provided herein.

## **6.12 TAXES**

**6.12.1** Contractor shall pay all sales, consumer, use, and other similar taxes required to be paid by Contractor in accordance with the Laws and Regulations of the place of the Project which are applicable during the performance of the Work.

## **6.13 USE OF SITE AND OTHER AREAS**

### **6.13.1 Limitation on Use of Site and Other Areas**

**6.13.1.1** Contractor shall confine construction equipment, the storage of materials and equipment, and the operations of workers to the Site and other areas permitted by Laws and Regulations, and shall not unreasonably encumber the Site and other areas with construction equipment or other materials or equipment. Contractor shall assume full responsibility for any damage to any such land or area, or to the owner or occupant thereof, or of any adjacent land or areas resulting from the performance of the Work.

**6.13.1.2** Should any claim be made by any such owner or occupant because of the performance of the Work, Contractor shall promptly settle with such other party by negotiation or otherwise resolve the claim by arbitration or other dispute resolution proceeding or at law.

**6.13.1.3** To the fullest extent permitted by Laws and Regulations, Contractor shall indemnify and hold harmless Municipalities, Engineer, Engineer's Consultant, and the officers, directors, partners, employees, agents, and other consultants of each and any of them from and against all claims, costs, losses, and damages (including but not limited to all fees and charges of engineers, architects, attorneys, and other professionals and all court or arbitration or other dispute resolution costs) arising out of or relating to any claim or action, legal or equitable, brought by any such owner or occupant against Municipalities, Engineer, or any other party indemnified hereunder to the extent caused by or based upon Contractor's performance of the Work.

**6.13.2** During the progress of the Work Contractor shall keep the Site and other areas free from accumulations of waste materials, rubbish, and other debris. Removal and disposal of such waste materials, rubbish, and other debris shall conform to applicable Laws and Regulations.

**6.13.3** Prior to Substantial Completion of the Work Contractor shall clean the Site and make it ready for utilization by Municipalities. At the completion of the Work Contractor shall remove from the Site all tools, appliances, construction equipment and machinery, and surplus materials and shall restore to original condition all property not designated for alteration by the Contract Documents.

**6.13.4 Loading Structures:** Contractor shall not load nor permit any part of any structure to be loaded in any manner that will endanger the structure, nor shall Contractor subject any part of the Work or adjacent property to stresses or pressures that will endanger it.

## **6.14 RECORD DOCUMENTS**

**6.14.1** Contractor shall maintain in a safe place at the Site one record copy of all Drawings, Specifications, Addenda, Written Amendments, Change Orders, Work Change Directives, Field Orders, and written interpretations and clarifications in good order and annotated to show changes made during construction. These record documents together with all approved Samples and a counterpart of all approved Shop Drawings will be available to Engineer for reference. Upon completion of the Work, these record documents, Samples, and Shop Drawings will be delivered to Engineer for Municipalities.

## **6.15 SAFETY**

**6.15.1** Contractor shall be solely responsible for initiating, maintaining and supervising all safety precautions and programs in connection with the Work. Contractor shall take all necessary precautions for the safety of, and shall provide the necessary protection to prevent damage, injury or loss to:

**6.15.1.1** all persons on the Site or who may be affected by the Work;

**6.15.1.2** all the Work and materials and equipment to be incorporated therein, whether in storage on or off the Site; and

**6.15.1.3** other property at the Site or adjacent thereto, including trees, shrubs, lawns, walks, pavements, roadways, structures, utilities, and Underground Facilities not designated-for removal, relocation, or replacement in the course of construction.

**6.15.2** Contractor shall comply with all applicable Laws and Regulations relating to the safety of persons or property, or to the protection of persons or property from damage, injury, or loss; and shall erect and maintain all necessary safeguards for such safety and protection. Contractor shall notify Municipalities of adjacent property and of Underground Facilities and other utility Municipalities when prosecution of the Work may affect them, and shall cooperate with them in the protection, removal, relocation, and replacement of their property. All damage, injury, or loss to any property referred to herein, caused, directly or indirectly, in whole or in part, by Contractor, any Subcontractor, Supplier, or any other individual or entity directly or indirectly employed by any of them to perform any of the Work, or anyone for whose acts any of them may be liable, shall be remedied by Contractor (except damage or loss attributable to the fault of Drawings or Specifications or to the acts or omissions of Municipalities or Engineer or Engineer's Consultant, or anyone employed by any of them, or anyone for whose acts any of them may be liable, and not attributable, directly or indirectly, in whole or in part, to the fault or negligence of Contractor or any Subcontractor, Supplier, or other individual



or entity directly or indirectly employed by any of them). Contractor's duties and responsibilities for safety and for protection of the Work shall continue until such time as all the Work is completed and Engineer has issued a notice to Municipalities and Contractor as required herein that the Work is acceptable (except as otherwise expressly provided in connection with Substantial Completion).

#### **6.16 SAFETY REPRESENTATIVE**

**6.16.1** Contractor shall designate a qualified and experienced safety representative at the Site whose duties and responsibilities shall be the prevention of accidents and the maintaining and supervising of safety precautions and programs.

#### **6.17 HAZARD COMMUNICATION PROGRAMS**

**6.17.1** Contractor shall be responsible for coordinating any exchange of material safety data sheets or other hazard communication information required to be made available to or exchanged between or among employers at the Site in accordance with Laws or Regulations.

#### **6.18 EMERGENCIES**

**6.18.1** In emergencies affecting the safety or protection of persons or the Work or property at the Site or adjacent thereto, Contractor is obligated to act to prevent threatened damage, injury, or loss. Contractor shall give Engineer prompt written notice if Contractor believes that any significant changes in the Work or variations from the Contract Documents have been caused thereby or are required as a result thereof. If Engineer determines that a change in the Contract Documents is required because of the action taken by Contractor in response to such an emergency, a Change Order will be issued.

#### **6.19 SHOP DRAWINGS AND SAMPLES**

**6.19.1** Contractor shall submit Shop Drawings to Engineer for review and approval in accordance with the acceptable schedule of Shop Drawings and Sample submittals. All submittals will be identified as Engineer may require and in the number of copies specified in the General Requirements. The data shown on the Shop Drawings will be complete with respect to quantities, dimensions, specified performance and design criteria, materials, and similar data to show Engineer the services, materials, and equipment Contractor proposes to provide and to enable Engineer to review the information for the limited purposes required by paragraph 6.19.5

**6.19.2** Contractor shall also submit Samples to Engineer for review and approval in accordance with the acceptable schedule of Shop Drawings and Sample submittals. Each Sample will be identified clearly as to material, supplier, pertinent data such as catalog numbers, and the use for which intended, and otherwise as Engineer may require to enable Engineer to review the submittal for the limited purposes required by paragraph

6.19.5. The numbers of each Sample to be submitted will be as specified in the Specifications.

**6.19.3** Where a Shop Drawing or Sample is required by the Contract Documents or the schedule of Shop Drawings and Sample submittals acceptable to Engineer as required herein, any related Work performed prior to Engineer's review and approval of the pertinent submittal will be at the sole expense and responsibility of Contractor.

#### **6.19.4 Submittal Procedures**

**6.19.4.1** Before submitting each Shop Drawing or Sample, Contractor shall have determined and verified:

**6.19.4.1(a)** all field measurements, quantities, dimensions, specified performance criteria, installation requirements, materials, catalog numbers, and similar information with respect thereto;

**6.19.4.1(b)** all materials with respect to intended use, fabrication, shipping, handling, storage, assembly, and installation pertaining to the performance of the Work;

**6.19.4.1(c)** all information relative to means, methods, techniques, sequences, and procedures of construction and safety precautions and programs incident thereto; and

**6.19.4.1(d)** Contractor shall also have reviewed and coordinated each Shop Drawing or Sample with other Shop Drawings and Samples and with the requirements of the Work and the Contract Documents.

**6.19.4.2** Each submittal shall bear a stamp or specific written indication that Contractor has satisfied Contractor's obligations under the Contract Documents with respect to Contractor's review and approval of that submittal.

**6.19.4.3** At the time of each submittal, Contractor shall give Engineer specific written notice of such variations, if any, that the Shop Drawing or Sample submitted may have from the requirements of the Contract Documents, such notice to be in a written communication separate from the submittal; and, in addition, shall cause a specific notation to be made on each Shop Drawing and Sample submitted to Engineer for review and approval of each such variation.

#### **6.19.5 Engineer's Review**

**6.19.5.1** Engineer will timely review and approve Shop Drawings and Samples in accordance with the Contractor's schedule of Shop Drawings and Sample submittals acceptable to Engineer (expected review time shall never be less than 10 days). Engineer's review and approval will be only to determine if the items covered by the submittals will, after installation or incorporation in the Work,

conform to the information given in the Contract Documents and be compatible with the design concept of the completed Project as a functioning whole as indicated by the Contract Documents.

**6.19.5.2** Engineer's review and approval will not extend to means, methods, techniques, sequences, or procedures of construction (except where a particular means, method, technique, sequence, or procedure of construction is specifically and expressly called for by the Contract Documents) or to safety precautions or programs incident thereto. The review and approval of a separate item as such will not indicate approval of the assembly in which the item functions.

**6.19.5.3** Engineer's review and approval of Shop Drawings or Samples shall not relieve Contractor from responsibility for any variation from the requirements of the Contract Documents unless Contractor has in writing called Engineer's attention to each such variation at the time of each submittal as required by paragraph 6.19.4 and Engineer has given written approval of each such variation by specific written notation thereof incorporated in or accompanying the Shop Drawing or Sample approval; nor will any approval by Engineer relieve Contractor from responsibility for complying with the requirements of paragraph 6.19.4.

#### **6.19.6 Resubmittal Procedures**

**6.19.6.1** Contractor shall make corrections required by Engineer and shall return the required number of corrected copies of Shop Drawings and submit as required new Samples for review and approval. Contractor shall direct specific attention in writing to revisions other than the corrections called for by Engineer on previous submittals.

### **6.20 CONTINUING THE WORK**

**6.20.1** Contractor shall carry on the Work and adhere to the progress schedule during all disputes or disagreements with Municipalities. No Work shall be delayed or postponed pending resolution of any disputes or disagreements, except as permitted herein or as Municipalities and Contractor may otherwise agree in writing.

### **6.21 GENERAL WARRANTY AND GUARANTEE**

**6.21.1** Contractor warrants and guarantees to Municipalities, Engineer, and Engineer's Consultants that all Work will be in accordance with the Contract Documents and will not be defective. Contractor's warranty and guarantee hereunder excludes defects or damage caused by:

**6.21.1.1** abuse, modification, or improper maintenance or operation by persons other than Contractor, Subcontractors, Suppliers, or any other individual or entity for whom Contractor is responsible; or

**6.21.1.2** wear and tear under normal usage.

**6.21.2** Contractor's obligation to perform and complete the Work in accordance with the Contract Documents shall be absolute. None of the following will constitute an acceptance of Work that is not in accordance with the Contract Documents, or a release of Contractor's obligation to perform the Work in accordance with the Contract Documents:

**6.21.2.1** observations by Engineer;

**6.21.2.2** recommendation by Engineer or payment by Municipalities of any progress or final payment;

**6.21.2.3** the issuance of a certificate of Substantial Completion by Engineer or any payment related thereto by Municipalities;

**6.21.2.4** use or occupancy of the Work or any part thereof by Municipalities;

**6.21.2.5** any acceptance by Municipalities or any failure to do so;

**6.21.2.6** any review and approval of a Shop Drawing or Sample submittal or the issuance of a notice of acceptability by Engineer;

**6.21.2.7** any inspection, test, or approval by others; or

**6.21.2.8** any correction of defective Work by Municipalities.

## **6.22 INDEMNIFICATION**

**6.22.1** To the fullest extent permitted by Laws and Regulations, Contractor shall indemnify and hold harmless Municipalities, Engineer, Engineer's Consultants, and the officers, directors, partners, employees, agents, and other consultants and subcontractors of each and any of them from and against all claims, costs, losses, and damages (including but not limited to all fees and charges of engineers, architects, attorneys, and other professionals and all court or arbitration or other dispute resolution costs) arising out of or relating to the performance of the Work, provided that any such claim, cost, loss, or damage:

**6.22.1.1** is attributable to bodily injury, sickness, disease, or death, or to injury to or destruction of tangible property (other than the Work itself), including the loss of use resulting therefrom; and

**6.22.1.2** is caused in whole or in part by any negligent act or omission of Contractor, any Subcontractor, any Supplier, or any individual or entity directly or indirectly employed by any of them to perform any of the Work or anyone for whose acts any of them may be liable, regardless of whether or not caused in part by any negligence or omission of an individual or entity indemnified hereunder or

whether liability is imposed upon such indemnified party by Laws and Regulations regardless of the negligence of any such individual or entity.

**6.22.2** In any and all claims against Municipalities or Engineer or any of their respective consultants, agents, officers, directors, partners, or employees by any employee (or the survivor or personal representative of such employee) of Contractor, any Subcontractor, any Supplier, or any individual or entity directly or indirectly employed by any of them to perform any of the Work, or anyone for whose acts any of them may be liable, the indemnification obligation under paragraph 6.22.1 shall not be limited in any way by any limitation on the amount or type of damages, compensation, or benefits payable by or for Contractor or any such Subcontractor, Supplier, or other individual or entity under workers' compensation acts, disability benefit acts, or other employee benefit acts.

**6.22.3** The indemnification obligations of Contractor under paragraph 6.22.1 shall not extend to the liability of Engineer and Engineer's Consultants or to the officers, directors, partners, employees, agents, and other consultants and subcontractors of each and any of them arising out of:

**6.22.3.1** the preparation or approval of, or the failure to prepare or approve, maps, Drawings, opinions, reports, surveys, Change Orders, designs, or Specifications; or

**6.22.3.2** giving directions or instructions, or failing to give them, if that is the primary cause of the injury or damage.

## **6.23 LAYOUT OF THE WORK**

**6.23.1** CONTRACTOR shall be solely responsible for layout of all Work.

## **ARTICLE 7 - CONTROL OF THE WORK**

### **7.1 AUTHORITY OF THE ENGINEER**

**7.1.1** The Engineer, acting as Municipalities's representative, shall decide all questions regarding the quality and acceptability of materials furnished, work performed, the rate of progress of the Work, the interpretation of the Contract, and the acceptable fulfillment of the Contract by the Contractor.

**7.1.2** If directed by the Municipalities, the Engineer will suspend the Work, wholly or in part, for such periods as may be necessary for the Contractor's failure to correct conditions unsafe for the Project personnel or general public, or carry out provisions of the Contract, or carry out orders of the Engineer. Notwithstanding the foregoing, action on the part of the Municipalities and/or Engineer pursuant to this section shall NOT be deemed to constitute a waiver of the sovereign immunity of the Municipalities, which immunity is hereby expressly reserved by the Municipalities nor shall any such action be claimed to and/or constitute a waiver of the CONTRACTOR's indemnification obligations specified elsewhere herein.

7.1.3 Work may also be wholly or partially suspended for periods necessary due to existing or forecasted unsuitable weather, or for conditions considered unsuitable for the prosecution of the Work such as hazardous materials, directives of the New Hampshire Department of Environmental Services, implementing emergency episode procedures, or any other condition or reason deemed to be in the Municipalities's interest.

## 7.2 VISITS TO SITE

7.2.1 Engineer will make visits to the Site at intervals appropriate to the various stages of construction as Engineer deems necessary in order to observe as an experienced and qualified design professional the progress that has been made and the quality of the various aspects of Contractor's executed Work. Based on information obtained during such visits and observations, Engineer, for the benefit of Municipalities, will determine, in general, if the Work is proceeding in accordance with the Contract Documents. Engineer will not be required to make exhaustive or continuous inspections on the Site to check the quality or quantity of the Work. Engineer's efforts will be directed toward providing for Municipalities a greater degree of confidence that the completed Work will conform generally to the Contract Documents. On the basis of such visits and observations, Engineer will keep Municipalities informed of the progress of the Work and will endeavor to guard Municipalities against defective Work.

7.2.2 Engineer's visits and observations are subject to all the limitations on Engineer's authority and responsibility set forth in Article 7, and particularly, but without limitation, during or as a result of Engineer's visits or observations of Contractor's Work Engineer will not supervise, direct, control, or have authority over or be responsible for Contractor's means, methods, techniques, sequences, or procedures of construction, or the safety precautions and programs incident thereto, or for any failure of Contractor to comply with Laws and Regulations applicable to the performance of the Work.

## 7.3 AUTHORIZED VARIATIONS IN WORK

7.3.1 Engineer may authorize minor variations in the Work from the requirements of the Contract Documents which do not involve an adjustment in the Contract Price or the Contract Times and are compatible with the design concept of the completed Project as a functioning whole as indicated by the Contract Documents. These may be accomplished by a Field Order and will be binding on Municipalities and also on Contractor, who shall perform the Work involved promptly. If Municipalities and Contractor are unable to agree on entitlement to or on the amount or extent, if any, of any adjustment in the Contract Price or Contract Times, or both, as a result of a Field Order, a Claim may be made therefore as provided herein.

## 7.4 INTERPRETATION OF CONTRACT DOCUMENTS AND ACCEPTABILITY OF WORK

7.4.1 Engineer will be the initial interpreter of the requirements of the Contract Documents and judge of the acceptability of the Work thereunder. Claims, disputes and

other matters relating to the acceptability of the Work, the quantities and classifications of Unit Price Work, the interpretation of the requirements of the Contract Documents pertaining to the performance of the Work, and Claims seeking changes in the Contract Price or Contract Times will be referred initially to Engineer in writing, with a request for a formal decision.

7.4.2 When functioning as interpreter and judge under the contract, Engineer will not show partiality to Municipalities or Contractor and will not be liable in connection with any interpretation or decision rendered in good faith in such capacity. The rendering of a decision by Engineer pursuant to the contract with respect to any such Claim, dispute, or other matter will be a condition precedent to any exercise by Municipalities or Contractor of such rights or remedies as either may otherwise have under the Contract Documents or by Laws or Regulations in respect of any such Claim, dispute, or other matter.

## 7.5 ENGINEER'S AUTHORITY AND RESPONSIBILITIES

7.5.1 Neither Engineer's authority nor responsibility under any provision of the Contract Documents nor any decision made by Engineer in good faith either to exercise or not exercise such authority or responsibility or the undertaking, exercise, or performance of any authority or responsibility by Engineer shall create, impose, or give rise to any duty in contract, tort, or otherwise owed by Engineer to Contractor, any Subcontractor, any Supplier, any other individual or entity, or to any surety for or employee or agent of any of them.

7.5.2 Engineer will not supervise, direct, control, or have authority over or be responsible for Contractor's means, methods, techniques, sequences, or procedures of construction, or the safety precautions and programs incident thereto, or for any failure of Contractor to comply with Laws and Regulations applicable to the performance of the Work. Engineer will not be responsible for Contractor's failure to perform the Work in accordance with the Contract Documents.

7.5.3 Engineer will not be responsible for the acts or omissions of Contractor or of any Subcontractor, any Supplier, or of any other individual or entity performing any of the Work.

7.5.4 Engineer's review of the final Application for Payment and accompanying documentation and all maintenance and operating instructions, schedules, guarantees, Bonds, certificates of inspection, tests and approvals, and other documentation, required to be delivered will only be to determine generally that their content complies with the requirements of, and in the case of certificates of inspections, tests, and approvals that the results certified indicate compliance with, the Contract Documents.

7.5.5 The limitations upon authority and responsibility set forth in this paragraph shall also apply to Engineer's Consultants, Resident Project Representative, and assistants.

7.5.6 The Contractor shall perform all necessary layout work not specified above in order to construct all elements of the Project as shown on the Plans and specified in the

Contract. This work shall include, but shall not be limited to stakeout necessary for re-establishment of line and grade as earthwork operations progress; stakeout, layout, and elevations as required for structures, forms, pile layouts, and paving. Prior to paving, the Contractor shall perform all work necessary to set the blue top stakes for fine grading.

## **ARTICLE 8 - TESTS AND INSPECTIONS**

### **8.1 DEFECTS**

**8.1.1** Prompt notice of all defective Work of which Municipalities or Engineer has actual knowledge will be provided to Contractor in writing. All defective Work may be rejected, corrected, or accepted as provided in this Article 8.

### **8.2 ACCESS TO WORK**

**8.2.1** Municipalities, Engineer, Engineer's Consultants, other representatives and personnel of Municipalities, independent testing laboratories, and governmental agencies with jurisdictional interests will have access to the Site and the Work at reasonable times for their observation, inspecting, and testing. Contractor shall provide them proper and safe conditions for such access and advise them of Contractor's Site safety procedures and programs so that they may comply therewith as applicable.

### **8.3 TESTS AND INSPECTIONS**

**8.3.1** Contractor shall give Engineer timely notice of readiness of the Work for all required inspections, tests, or approvals and shall cooperate with inspection and testing personnel to facilitate required inspections or tests.

**8.3.2** Municipalities shall employ and pay for the services of any additional independent testing laboratory required to perform inspections, tests, or approvals as directed by the Municipalities to confirm the Work is in compliance with the specifications unless results of said testing proves non-compliant Work. Then all costs shall be borne by the Contractor.

**8.3.3** Municipalities shall not be responsible for testing/inspection costs associated with the following:

**8.3.3.1** for inspections, tests, or approvals covered by paragraphs 8.3.4 and 8.3.5 below;

**8.3.3.2** those costs incurred in connection with tests or inspections conducted pursuant to paragraph 8.4.2 shall be paid as provided in said paragraph 8.4.2; and

**8.3.3.3** as otherwise specifically provided in the Contract Documents.

**8.3.4** If Laws or Regulations of any public body having jurisdiction require any Work (or part thereof) specifically to be inspected, tested, or approved by an employee or other



representative of such public body, Contractor shall assume full responsibility for arranging and obtaining such inspections, tests, or approvals, pay all costs in connection therewith, and furnish Engineer the required certificates of inspection or approval.

**8.3.5** Contractor shall be responsible for arranging and obtaining and shall pay all costs in connection with any inspections, tests, or approvals required for Municipalities' and Engineer's acceptance of materials or equipment to be incorporated in the Work; or acceptance of materials, mix designs, or equipment submitted for approval prior to Contractor's purchase thereof for incorporation in the Work. Such inspections, tests, or approvals shall be performed by organizations acceptable to Municipalities and Engineer.

**8.3.6** If any Work (or the work of others) that is to be inspected, tested, or approved is covered by Contractor without written concurrence of Engineer, it must, if requested by Engineer, be uncovered for observation.

**8.3.7** Uncovering Work as provided in paragraph 8.3.6 shall be at Contractor's expense unless Contractor has given Engineer timely notice of Contractor's intention to cover the same and Engineer has not acted with reasonable promptness in response to such notice.

#### **8.4** QUALITY ASSURANCE/QUALITY CONTROL

**8.4.1** The CONTRACTOR shall be responsible for assuring that all work and materials, complete and in-place, meet or exceed the standards of quality specified or implied in the Contract Documents.

**8.4.2** The ENGINEER will employ an independent testing agency to conduct construction quality control testing for earthwork and cast-in-place concrete. Agency name and contact person will be provided to the CONTRACTOR upon Notice to Proceed.

**8.4.3** The CONTRACTOR shall adhere to certain general testing and quality control requirements under this Contract. The CONTRACTOR shall:

**8.4.3.1** Schedule and coordinate all testing and inspections and notify the testing agency and the ENGINEER sufficiently in advance of operations to allow for the proper assignment of personnel and scheduling of tests.

**8.4.3.2** Cooperate with testing agency and the ENGINEER and provide access to the work for testing.

**8.4.3.3** Provide representative samples of materials to be tested, in required quantities.

**8.4.3.4** Furnish labor and facilities:

- (1) To provide access to work to be tested.
- (2) To obtain and handle samples at the site.

- (3) To facilitate inspections and tests.
- (4) For storage and curing of test samples.

**8.4.3.5** Assure that required inspection, sampling and testing has been conducted prior to commencement of any work which would alter or cover the work to be inspected, sampled and/or tested.

**8.4.4** All work under this Contract shall be subject to inspection and observation by representatives of the Municipalities and the ENGINEER.

**8.4.5** In the event that any quality control testing, inspection or observation results in any indication that any material or portion of the work does not meet Contract requirements, the CONTRACTOR shall, at his sole expense, undertake remedial work and/or repeat testing to the satisfaction of the ENGINEER.

**8.4.6** QUALITY CONTROL TESTING FOR EARTHWORK (DELETED)

**8.4.7** QUALITY CONTROL TESTING FOR CAST-IN-PLACE CONCRETE (DELETED)

## **8.5 UNCOVERING WORK**

**8.5.1** If any Work is covered contrary to the written request of Engineer, it must, if requested by Engineer, be uncovered for Engineer's observation and replaced at Contractor's expense.

**8.5.2** If Engineer considers it necessary or advisable that covered Work be observed by Engineer or inspected or tested by others, Contractor, at Engineer's request, shall uncover, expose, or otherwise make available for observation, inspection, or testing as Engineer may require, that portion of the Work in question, furnishing all necessary labor, material, and equipment. If it is found that such Work is defective, Contractor shall, pay all Claims, costs, losses, and damages (including but not limited to all fees and charges of engineers, architects, attorneys, and other professionals and all court or arbitration or other dispute resolution costs) arising out of or relating to such uncovering, exposure, observation, inspection, and testing, and of satisfactory replacement or reconstruction (including but not limited to all costs of repair or replacement of work of others); and Municipalities shall be entitled to an appropriate decrease in the Contract Price. If such Work is not found to be defective, Contractor shall be allowed an extension of the Contract Times (or Milestones), directly attributable to such uncovering, exposure, observation, inspection, testing, replacement, and reconstruction. If the parties are unable to agree as to the amount or extent thereof, Contractor may make a Claim therefore as provided herein.

## **8.6 MUNICIPALITY RIGHT TO STOP WORK**

**8.6.1** If the Work is defective, or Contractor fails to supply sufficient skilled workers or suitable materials or equipment, or fails to perform the Work in such a way that the completed Work will conform to the Contract Documents, Municipalities may order Contractor to stop the Work, or any portion thereof, until the cause for such order has

been eliminated; however, the Municipalities' right to stop the Work shall not give rise to any duty on the part of Municipalities to exercise this right for the benefit of Contractor, any Subcontractor, any Supplier, any other individual or entity, or any surety for, or employee or agent of any of them.

## **8.7 CORRECTION OR REMOVAL OF DEFECTIVE WORK**

**8.7.1** Contractor shall correct all defective Work, whether or not fabricated, installed, or completed, or, if the Work has been rejected by Engineer, remove it from the Project and replace it with Work that is not defective. Contractor shall pay all Claims, costs, losses, and damages (including but not limited to all fees and charges of engineers, architects, attorneys, and other professionals and all court or arbitration or other dispute resolution costs) arising out of or relating to such correction or removal (including but not limited to all costs of repair or replacement of work of others).

## **8.8 CORRECTION PERIOD**

**8.8.1** If within one year after the date of Substantial Completion or such longer period of time as may be prescribed by Laws or Regulations or by the terms of any applicable special guarantee required by the Contract Documents or by any specific provision of the Contract Documents, any Work is found to be defective, or if the repair of any damages to the land or areas made available for Contractor's use by Municipalities or permitted by Laws and Regulations as contemplated herein is found to be defective, Contractor shall promptly, without cost to Municipalities and in accordance with Municipalities's written instructions: (i) repair such defective land or areas, or (ii) correct such defective Work or, if the defective Work has been rejected by Municipalities, remove it from the Project and replace it with Work that is not defective, and (iii) satisfactorily correct or repair or remove and replace any damage to other Work, to the work of others or other land or areas resulting therefrom. If Contractor does not promptly comply with the terms of such instructions, or in an emergency where delay would cause serious risk of loss or damage, Municipalities may have the defective Work corrected or repaired or may have the rejected Work removed and replaced, and all Claims, costs, losses, and damages (including but not limited to all fees and charges of engineers, architects, attorneys, and other professionals and all court or arbitration or other dispute resolution costs) arising out of or relating to such correction or repair or such removal and replacement (including but not limited to all costs of repair or replacement of work of others) will be paid by Contractor.

**8.8.2** In special circumstances where a particular item of equipment is placed in continuous service before Substantial Completion of all the Work, the correction period for that item may start to run from an earlier date if so provided in the Specifications or by Written Amendment.

**8.8.3** Where defective Work (and damage to other Work resulting therefrom) has been corrected or removed and replaced under this paragraph 8.7, the correction period

hereunder with respect to such Work will be extended for an additional period of one year after such correction or removal and replacement has been satisfactorily completed.

**8.8.4** Contractor's obligations under this paragraph 8.7 are in addition to any other obligation or warranty. The provisions of this paragraph 8.7 shall not be construed as a substitute for or a waiver of the provisions of any applicable statute of limitation or repose.

## **8.9 ACCEPTANCE OF DEFECTIVE WORK**

**8.9.1** If, instead of requiring correction or removal and replacement of defective Work, Municipalities (and, prior to Engineer's recommendation of final payment, Engineer) prefers to accept it, Municipalities may do so. Contractor shall pay all Claims, costs, losses, and damages (including but not limited to all fees and charges of engineers, architects, attorneys, and other professionals and all court or arbitration or other dispute resolution costs) attributable to Municipalities's evaluation of and determination to accept such defective Work (such costs to be approved by Engineer as to reasonableness) and the diminished value of the Work to the extent not otherwise paid by Contractor pursuant to this sentence. If any such acceptance occurs prior to Engineer's recommendation of final payment, a Change Order will be issued incorporating the necessary revisions in the Contract Documents with respect to the Work, and Municipalities shall be entitled to an appropriate decrease in the Contract Price, reflecting the diminished value of Work so accepted. If the acceptance occurs after such recommendation, an appropriate amount will be paid by Contractor to Municipalities.

## **8.10 MUNICIPALITIES RIGHT TO CORRECT DEFECTIVE WORK**

**8.10.1** If Contractor fails within a reasonable time after written notice from Engineer to correct defective Work or to remove and replace rejected Work as required by Engineer in accordance with paragraph 8.6, or if Contractor fails to perform the Work in accordance with the Contract Documents, or if Contractor fails to comply with any other provision of the Contract Documents, Municipalities may, after seven days written notice to Contractor, correct and remedy any such deficiency.

**8.10.2** In exercising the rights and remedies under this paragraph, Municipalities shall proceed expeditiously. In connection with such corrective and remedial action, Municipalities may exclude Contractor from all or part of the Site, take possession of all or part of the Work and suspend Contractor's services related thereto, take possession of Contractor's tools, appliances, construction equipment and machinery at the Site, and incorporate in the Work all materials and equipment stored at the Site or for which Municipalities has paid Contractor but which are stored elsewhere. Contractor shall allow Municipalities, Municipalities's representatives, agents and employees, Municipalities's other contractors, and Engineer and Engineer's Consultants access to the Site to enable Municipalities to exercise the rights and remedies under this paragraph.

**8.10.3** All Claims, costs, losses, and damages (including but not limited to all fees and charges of engineers, architects, attorneys, and other professionals and all court or arbitration or other dispute resolution costs) incurred or sustained by Municipalities in exercising the rights and remedies under this paragraph 8.9 will be charged against Contractor, and a Change Order will be issued incorporating the necessary revisions in the Contract Documents with respect to the Work; and Municipalities shall be entitled to an appropriate decrease in the Contract Price. Any claims by the Municipalities resulting from the parties' inability to agree will include but not be limited to all costs of repair, or replacement of work of others destroyed or damaged by correction, removals or replacement of Contractor's defective Work.

**8.10.4** Contractor shall not be allowed an extension of the Contract Times (or Milestones) because of any delay in the performance of the Work attributable to the exercise by Municipalities of Municipalities's rights and remedies under this paragraph 8.9.

## **ARTICLE 9 - PAYMENTS TO CONTRACTOR AND COMPLETION**

### **9.1 MEASUREMENT AND PAYMENT**

**9.1.1 Measurement of Quantities.** Work completed under the Contract will be measured by the Engineer according to the United States customary measure.

A station, when used as a definition or term of measurement, will be 100 linear feet measured horizontally.

The method of measurement and computations to be used in determination of quantities of material furnished and work performed will be those methods generally recognized as conforming to good engineering practice.

Unless otherwise specified, longitudinal measurements for area computations will be made horizontally, and no deductions will be made for individual objects having an area of 9 square feet or less. Unless otherwise specified, transverse measurements for area computations will be the neat dimensions shown on the plans or ordered in writing.

Structures will be measured according to neat lines shown on the plans or as ordered to fit field conditions.

Items which are measured by the linear foot, such as pipe culverts, guardrail, curb, underdrains, etc., will be measured parallel to the base or foundation upon which such structures are placed.

In computing volumes of excavation, embankment, and borrow, the average end area method will be used. Where it is impracticable to measure material by the cross-section method due to irregular, isolated deposits, acceptable methods involving three-dimensional measurement may be used. When measurement of materials in vehicles is permitted, the quantity will be determined as 80 percent of the loose volume.

In computing volumes of concrete and masonry, the prismoidal method will be used.

The space occupied by pipe will not be included in the volume of headwalls. In the case of pipe having a wall thickness of 2 inches or more, the area of the pipe will be based on the manufacturer's nominal dimensions, outside to outside, or the shell of the pipe. In the case of pipe having a wall thickness of less than 2 inches, the area of the pipe will be based on the nominal inside diameter of the pipe.

The thickness of plates and galvanized sheets used in the manufacture of corrugated metal pipe, metal plate pipe culverts and arches, and metal cribbing will be specified and measured in decimal fractions of inches.

The term "ton" will mean the short ton consisting of 2,000 pounds. Except as specified below, materials which are measured or proportioned by weight shall be weighed on scales which the Contractor has had sealed by the New Hampshire Department of Agriculture or by a company approved by that Department. All weighing shall be performed in a manner prescribed under the Rules and Regulations of the Bureau of Weights and Measures of the New Hampshire Department of Agriculture. Weighing of materials on scales located outside New Hampshire will be permitted for materials produced or stored outside the State, when requested by the Contractor. Out-of-state weighing, in order to be approved, must be performed on scales sealed by the appropriate governmental authority.

If material is shipped by rail, the car weight may be accepted, provided that payment is made only for the actual weight of material. Car weights will not be acceptable for material to be passed through mixing plants.

Trucks used to haul material being paid for by weight shall be weighed empty daily at times directed by the Engineer. Each truck shall bear a plainly legible identification mark.

When material is weighed, the individual weight slips, which shall be furnished by the Contractor, for trucks, trailers, or distributors, shall show the following information: the date, the project name and number; slip number; the material or commodity; the dealer of vendor; the Contractor or Subcontractor; the location of the scales; the time of loading; the vehicle registration number or other approved legible identification mark; the tare and net weights, with gross weights when applicable; and the weigher's name, signature, or signed initials.

The right is reserved to weigh any truck, trailer, or distributor, at locations designated, before and after making deliveries to the Project.

When requested by the Contractor and approved or ordered by the Engineer in writing, material specified to be measured by the cubic yard may be weighed and converted to cubic yards. Factors for conversion from weight measurement to volume measurement will be determined by the Engineer and agreed to by the Contractor before this method of measurement of pay quantities is used.

Bituminous materials will be measured by the gallon.

Timber will be measured by the thousand feet board measure (MBM) actually incorporated in the structure. Measurement will be based on nominal widths, thicknesses, and the extreme length of each piece.

The term “lump sum,” when used as an item of payment, will mean complete payment for the Work described in the Contract.

When a complete structure of structural unit (in effect, “lump sum” work) is specified as the unit of measurement, the unit includes all necessary fittings and accessories.

Except as may be otherwise provided, partial payments for lump sum items will be made approximately in proportion to the amount of the work completed on those items.

Rental of equipment will be measured in hours of actual working time and necessary travel time of the equipment within the limits of the Project. If special equipment has been ordered by the Engineer in connection with force account work, travel time and transportation to the project will be measured. If equipment is ordered held on the property on a standby basis by the Engineer, payments will be made as provided herein.

When standard manufactured items are specified such as fence, wire, plates, rolled shapes, pipe, conduit, etc. and these items are identified by gauge, unit weight, section dimensions, etc., the identification will be considered to be nominal weights or dimensions. Unless more stringently controlled by tolerances in cited specifications, manufacturing tolerances established by the industries involved will be accepted.

Material wasted without authority will not be included in the final pay quantity.

When the estimated quantities for a specific portion of the Work are designated as final pay quantities in the Contract, they shall be the final pay quantities for which payment will be made in accordance with 9.14.

**9.1.2 Scope of Payment.** The Contractor shall receive and accept compensation provided for in the Contract as full payment for furnishing all materials; for performing work under the Contract in a complete and acceptable manner; and for all risk, loss, damage, or expense arising out of the nature or prosecution of the work, subject to the provisions contained herein.

**9.1.3 Compensation for Altered Quantities.** When the accepted quantities of work vary from the quantities in the Contract, the Contractor shall accept payment at the original Contract unit prices for the accepted quantities of work done.

**9.1.4 Differing Site Conditions, Changes, Extra Work, and Force Account Work.** Differing Site Conditions, changes and Extra Work performed under Article 5.2 will be paid for using the following methods as appropriate:

- Contract unit prices.
- Unit prices agreed upon in the order authorizing the work.
- An agreed upon lump sum amount.
- If directed by the Department, on a force account basis to be compensated in the following manner:

**9.1.4.1 Labor.** For all labor, including equipment operators, and foremen in direct charge of the specific operation, the Contractor shall receive the rate of wage agreed to in writing for each and every hour that the labor and foreman are actually engaged in the work. In case the Contractor is required to pay overtime pay or holiday pay to labor engaged in the Work, such rate will be the rate reimbursed. When the Contractor is ordered to return to the project solely to perform Extra Work, labor will be considered as being actually engaged in the Work during the hours while traveling.

No part of the salary or expenses of anyone connected with the Contractor's forces above the grade of foreman and having general supervision of the Work will be included in the labor item as specified above, except under any of the following conditions: (1) The work ordered is of an emergency nature or is ordered too late to be done before all work shown on the Plans or provided for in the Proposal has been substantially accomplished, (2) the Contractor's organization is entirely occupied with Extra Work, or (3) the nature of the work is such that the services of superintendents and timekeepers may be included in the classification of labor. In order to determine the allowable rate of pay of eligible superintendents, foremen, and timekeepers, a notarized statement shall be furnished to the Engineer. In case no documentary evidence of the actual rate of pay is furnished for such superintendents, foremen and timekeepers, no reimbursement will be allowed. Transportation for a superintendent will be paid for as equipment in the manner specified in (3) below.

The Contractor will also receive an additional amount (i.e. a labor burden rate) equal to 50 percent of the actual hourly rate paid to, or in behalf of workers, for costs of health and welfare benefits, taxes, insurances, retirement (including social security taxes), union benefits, and unemployment insurance premiums.

The unemployment insurance rate shall be the lesser of the Contractor's current unemployment insurance rate or the Unemployment Insurance Rate for New Employer established by the New Hampshire Department of Employment Security. The worker's compensation rate shall be the National Council on Compensation Insurance published rates approved by the New Hampshire Department of Insurance. All rates paid will be the Contractor's policy rate in effect at the time work is performed. For work outside the State of New Hampshire, the rates paid shall be the rates established by the



appropriate agency of the State in which the work is performed. The Contractor shall furnish evidence of the rate or rates paid for such insurance, and taxes.

A Contractor can request a different labor burden rate be used if an independently audited breakdown of the actual aforementioned costs, prepared by a Certified Public Accountant, is provided. The audit of the burden rate shall be prepared on current financial data and in conformity with the accounting practices prescribed by the Federal Acquisition Regulations 48 CFR, Part 31.

An amount equal to ten percent of the sum of the above labor-related items will also be paid the Contractor.

Subsistence and travel expenses paid by the Contractor will be reimbursed only when the Engineer orders Extra Work and in order to perform such work, it is necessary to move workers to the project particularly for that operation. Such subsistence and travel expenses allowed shall be carried on the daily report form under the classification of "Material," without, however, being subject to the added percentage for materials. If work other than such Extra Work is performed by the individuals during or in connection with that operation, no subsistence or travel expenses will be allowed.

**9.1.4.2 Materials and Specialized Work.** When the Engineer directs special work not included in the Contract, requiring skills, tools, and equipment unlike those used by the Contractor, payment may be made for such work performed by a specialist. For specialist services, and materials accepted by the Engineer whether furnished by a specialist or by the Contractor, the Contractor will receive the actual cost, including transportation charges paid (exclusive of equipment rentals and hereinafter set forth), to which cost 15 percent will be added. Invoices not exceeding a value of two thousand dollars per work event for specialist services on the basis of the current market price thereof may be accepted without complete itemization of labor, material, and equipment rental costs when it is impracticable and not in accordance with the established practice of the special service industry to provide such complete itemization. If specialized work is carried out by a subcontractor, provisions of paragraph 5 herein shall apply.

The cost of materials will be the cost to the purchaser, whether Contractor, Subcontractor, or other, from the supplier thereof, except as the following are applicable:

- a. If materials are procured by the purchaser by any method which not a direct purchase is from and a direct billing by the actual supplier to such purchaser, the cost of such materials will be deemed to be the price paid to

the actual supplier as determined by the Engineer. No markup except for actual costs incurred in the handling of such materials will be permitted.

- b. If the materials are obtained from a supply or source owned wholly or in part by the purchaser, payment will not exceed the price paid by the purchaser for similar materials furnished from said source on contract items or the current wholesale price for such materials delivered to the job site, whichever price is lower.
- c. If, in the opinion of the Engineer, the cost of such materials is excessive, then the cost of such material will be deemed to be the lowest current wholesale price at which such materials are available in the quantities concerned delivered to the job site.
- d. If the Contractor does not furnish satisfactory evidence of the cost of such materials from the actual supplier, the cost will then be determined in accordance with paragraph (c).

**9.1.4.3 Equipment and Plant.** For any Contractor-owned machinery or special equipment (other than small tools), the use of which is approved by the Engineer, the hourly rate will not exceed that determined from the latest edition of the “Rental Rate Blue Book for Construction Equipment” published by Dataquest, Inc. used in the following manner.

- a. The hourly equipment rental rate (R) will be determined by formula as follows:

$$R = (A \times B \times C) + D$$

Where

- A = Monthly rate divided by 176. The listed weekly, hourly, and daily rates will not be used.
  - B = Average regional adjustment factor for New Hampshire.
  - C = Factor from Rate Adjustment Table for the year of equipment manufacture.
  - D = Estimated operating costs per hour.
- b. The number of hours to be paid for will be the number of hours that the equipment or plant is actually used on a specific Force Account activity and in addition, shall include the time required to move the equipment to the location of such force account activity and return it to the original location or to another location requiring no more time than that required to return it to its original location, except that moving time will not be paid for if the equipment is used during the move on work other than the specific Force Account activity.
  - c. The current revision of the “Blue Book” applicable to the specific Force Account work is as of the beginning of the calendar year in which Extra Work is being performed. Revised sections published during the year will

not be incorporated in the “Blue Book” until the beginning of the next calendar year.

- d. The average regional adjustment factor applicable for this Contract will be specified in the Supplemental Specification for this Subsection. The average regional adjustment factor will be reviewed and revised annually subsequent to revisions of “Blue Book” sections. Equipment life adjustments will be made using the rate adjustment tables.
- e. Overtime shall be charged at the same rate indicated in subparagraph (a) above.
- f. The estimated operating costs per hour will be used for each hour that the equipment or plant is in operation on the Force Account work. Such costs do not apply to idle time regardless of the idleness.
- g. The maximum rental period to be paid for per day shall not exceed eight hours unless the equipment operates for eight or more hours.
- h. The rates established above shall include the cost of fuel, oil, lubrication, supplies, small tools, necessary attachments, repairs, overhauls and maintenance of any kind, depreciation, storage, overhead, profits, insurance and all incidentals.

The Contractor shall provide the Engineer with the following: the manufacturer’s name, equipment type, year of manufacture, model number, type of fuel used, horsepower rating, attachments required, together with their size or capacity, and any further information necessary to ascertain the proper rate. Unless otherwise specified, manufacturer’s ratings and manufacturer approved modifications shall be used to classify equipment for the determination of applicable rental rates. Equipment which has no direct power unit shall be powered by a unit of at least the minimum rating recommended by the manufacturer. The Contractor shall have available for the Engineer’s use a revised copy of the “Blue Book” as referenced in above.

Equipment used by the Contractor shall be in good working condition and shall be of suitable size and suitable capacity required for the work to be performed. The rate for the basic equipment with the appropriate attachments shall include only the rate for the combined equipment necessary to perform the extra work. In case the Contractor elects to use equipment of a higher rental value than that suitable for the work, payment will be made at the rate applicable to the suitable equipment. The equipment actually used and the suitable equipment to be paid for will be recorded as a part of the record for Extra Work. The Engineer will determine the suitability of the equipment. If there is a differential in the rate of pay of the operator of oversize or higher rate equipment, the rate paid for the operator will likewise be that for the suitable equipment.

Payable time periods will not include: (1) time elapsed while equipment is inoperative due to breakdowns, (2) time spent repairing equipment, or (3) time elapsed 24 hours after the Engineer has advised the Contractor that the equipment is no longer needed.

If a piece of equipment is needed that is not listed in the above stated rental rate guide, a rate will be established by the Engineer in writing before the equipment is used. The Contractor may furnish any cost data which might assist the Engineer in the establishment of such rate.

If the Contractor does not own a specific type of equipment and must obtain it by rental, the Contractor shall inform the Contract Administrator of the need to rent the equipment and of the rental rate for that equipment before using it on the work. The Contractor will be paid the actual rental for the equipment for the time that the equipment is actually used to accomplish the work provided that the rate is reasonable, plus the cost of moving the equipment onto and away from the job. The Contractor shall provide a copy of the paid receipt or canceled check for the rental expense incurred.

Transportation charges for each piece of equipment, whether owned or rented, moved to and from the site of the work will be paid provided: (1) the equipment is obtained from the nearest approved source, (2) the return charges do not exceed the delivery charges, (3) haul rates do not exceed the established rates of licensed haulers, (4) charges are restricted to those units or equipment not already available and not on or near the Project, and (5) equipment is not used elsewhere on the project.

**9.1.4.4 Miscellaneous.** No additional allowance will be made for general superintendence, the use of small tools, or for other costs for which no specific allowance is provided.

**9.1.4.5 Subcontracting.** For administration costs in connection with approved subcontract work, the Contractor shall receive an amount equal to five percent of the total cost of work computed as set forth above, except that no percentage will be allowed for equipment rented from the Contractor. In the event lower tier subcontracting is required, the administration cost shall not exceed a combined total of 20% of the actual cost of the work as computed above.

**9.1.4.6 Bond.** The Contractor will receive the actual costs for bond premium as a percentage of the total cost of the Work computed as set forth above for work paid under items not originally in the contract. The Contractor shall furnish evidence of the rate paid for such bond.

**9.1.4.7 Compensation.** The compensation herein provided shall be accepted by the contractor as payment in full for Force Account work, including

superintendence (except as provided in (1) above), subcontracting, taxes, bond, overhead, profit, and other costs in connection with the Work which are not provided for.

**9.1.4.8 Statements.** The Contractor's representative and the Engineer each day shall compare records of the cost of work completed on a Force Account basis. These daily records shall be set forth on the forms provided by the Engineer and shall thereafter be considered to be the basis for payment of the work performed, but shall not preclude subsequent adjustment based on a late audit by the Department.

No payments will be made for work performed on a Force Account basis until the Contractor has furnished the Engineer with a statement of the cost of the Force Account work showing the following:

- a. Name of subcontractor, if appropriate.
- b. Name, classification, date, daily hours, total hours, rate, and extension for each laborer, operator, and foreman.
- c. Quantities of materials, prices, and extensions.
- d. Charges for transportation of materials.
- e. Specialized work charges.
- f. Designation, dates, daily hours, total hours, rental rate, and extension for each unit of equipment or plant.

The Contractor shall certify that the labor, materials, and equipment listed were actually used on the Force Account Extra Work described, that the labor and equipment were used for the hours indicated and that the rates for labor do not exceed those for comparable labor currently employed on the project.

Statements shall be accompanied and supported by certified copies of the appropriate payrolls, and invoices for all materials and specialized work and for transportation charges. If materials used on the Force Account work are not specifically purchased for the work but are taken from the Contractor's stock, the Engineer shall be furnished an affidavit certifying that the materials were taken from stock, that the quantity claimed was actually used, and that the price and transportation claimed represents the Contractor's actual cost.

During the life of the contractor and for a period of not less than three years after the date of Acceptance thereof, the Contractor's cost records pertaining to work paid for on an Extra Work basis shall be open to inspection or audit by representatives of the Department, and the Contractor shall retain such records for that period. Where payment for materials or labor is based on the cost thereof to forces other than the Contractor, the Contractor shall make every reasonable effort to ensure that the cost records of such other forces will

be open to inspection and audit by representatives of the Municipalities on the same terms and conditions as the cost records of the Contractor.

**9.1.4.9 Final Pay Quantity.** When an item of work is designated as a final pay quantity in the Method of Measurement, or Basis of Payment, or Bid Schedule as (F), the estimated bid quantity for that item of work shall be the final pay quantity, unless the dimensions of any portion or the quantity of that item are revised by the Engineer, or the item or any portion of the item is eliminated. If the dimensions of any portion or the quantity of the item are revised, and the revision results in an increase or decrease in the estimated quantity of that item of work, the final pay quantity for the item will be revised in the amount represented by the changes in the dimensions or the quantity. If a final pay item is eliminated, the estimated quantity for the item will be eliminated. If a portion of a final pay item is eliminated, the final pay quantity will be revised in the amount represented by the eliminated portion of the item of work.

The estimated quantity for each item of work designated as a final pay quantity in the Method of Measurement or Basis of Payment or Bid Schedule shall be considered as approximate only, and no guarantee is made that the quantity which can be determined by computations, based on the details and dimensions shown on the plans, will equal the estimated quantity. No adjustment will be made in the event that the quantity based on computations does not equal the estimated quantity except under the following conditions:

- a. A quantity adjustment (increase or decrease) to the estimated bid quantity will be made if either the actual quantity is more than 125 percent or less than 75 percent of the estimated bid quantity for roadway items, or the value of the actual quantity is more than or less than \$10,000.00 of the estimated bid quantity value.
- b. A quantity adjustment (increase or decrease) to the estimated bid quantity will also be made if either the actual quantity per bridge structure is more than 125 percent or less than 75 percent of the estimated bid quantity for that bridge item or the value of the actual quantity is more than or less than \$10,000.00 of the estimated bid quantity value.

In case of discrepancy between the quantity shown in the Bid Schedule for a final pay item and the quantity or summation of quantities for the same item shown on the plans or in the proposal, payment will be based on the quantity shown in the Bid Schedule.

## **9.2 SCHEDULE OF VALUES AND PARTIAL PAYMENT APPLICATIONS**

**9.2.1** The schedule of values established as provided herein shall serve as the basis for progress payments and will be incorporated into a form of Application for Payment

acceptable to Engineer. Progress payments on account of Unit Price Work will be based on the number of units completed.

**9.2.2** At least 5 days before the date established for each progress payment (but not more often than once a month), Contractor shall submit to Engineer for review an Application for Payment filled out and signed by Contractor covering the Work completed as of the date of the Application and accompanied by such supporting documentation as is required by the Contract Documents. If payment is requested on the basis of materials and equipment not incorporated in the Work but delivered and suitable stored at the Site or at another location agreed to in writing, the Application for Payment shall also be accompanied by a bill of sale, invoice, or other documentation warranting that Municipalities has received the materials and equipment free and clear of all Liens and evidence that the materials and equipment are covered by appropriate property insurance or other arrangements to protect Municipalities' interest therein, all of which must be satisfactory to Municipalities.

**9.2.3** Unless specifically waived by a Special Provision or Supplemental Condition, the Municipalities shall retain ten (10) percent of the amount of progress payments until completion and acceptance of all Work under the Contract; except, that if upon completion of 50 percent of the Work, the Contracting Officer, after consulting with the Engineer, determines that the Contractor's performance and progress are satisfactory, the Municipalities may make the remaining payments in full for the Work subsequently completed. If the Contracting Officer subsequently determines that the Contractor's performance and progress are unsatisfactory, the Municipalities shall reinstate the ten (10) percent retainage until such time as the Contracting Officer determines that performance and progress are satisfactory.

**9.2.4** The Contracting Officer may authorize material delivered on the site and preparatory work done to be taken into consideration when computing progress payments. Material delivered to the Contractor at locations other than the site may also be taken into consideration if the Contractor furnishes satisfactory evidence that (1) it has acquired title to such material; (2) the material is properly stored in a bonded warehouse, storage yard, or similar suitable place as may be approved by the Contracting Officer; (3) the material is insured to cover its full value; and (4) the material will be used to perform this Contract. Before any progress payment which includes delivered material is made, the Contractor shall furnish such documentation as the Contracting Officer may require to assure the protection of the Municipalities' interest in such materials. The Contractor shall remain responsible for such stored material notwithstanding the transfer of title to the Municipalities.

**9.2.5** All material and work covered by progress payments made shall, at the time of payment become the sole property of the Municipalities, but this shall not be construed as (1) relieving the Contractor from the sole responsibility for all material and work upon which payments have been made or the restoration of any damaged work; or (2) waiving the right of the Municipalities to require the fulfillment of all of the terms of the contract. In the event the work of the Contractor has been damaged by other contractors or persons

other than employees of the Municipalities in the course of their employment, the Contractor shall restore such damaged work without cost to the Municipalities and to seek redress for its damage only from those who directly caused it.

**9.2.6** Beginning with the second Application for Payment, each Application shall include an affidavit of Contractor stating that all previous progress payments received on account of the Work have been applied on account to discharge Contractor's legitimate obligations associated with prior Applications for Payment. The amount of retainage with respect to progress payments will be as stipulated in the Agreement.

**9.2.7** Within 10 days after receipt of each Application for Payment, the Engineer shall either indicate in writing a recommendation of payment and present the Application to Municipalities or return the Application to Contractor indicating in writing Engineer's reasons for refusing to recommend payment. In the latter case, Contractor may make the necessary corrections and resubmit the Application.

**9.2.8** Engineer's recommendation of any payment requested in an Application for Payment will constitute a representation by Engineer to Municipalities, based on Engineer's observations on the Site of the executed Work as an experienced and qualified design professional and on Engineer's review of the Application for Payment and the accompanying data and schedules, that to the best of Engineer's knowledge, information and belief that:

**9.2.8.1** The quality of the Work is generally in accordance with the Contract Documents (subject to an evaluation of the Work as a functioning whole prior to or upon Substantial Completion, to the results of any subsequent tests called for in the Contract Documents, to a final determination of quantities and classifications for Unit Price Work, and to any other qualifications stated in the recommendation); and

**9.2.8.2** The conditions precedent to Contractor being entitled to such payment appears to have been fulfilled in so far as it is Engineer's responsibility to observe the Work.

**9.2.8.3** By recommending any such payment Engineer will not thereby be deemed to have represented that: (i) inspections made to check the quality or the quantity of the Work as it has been performed have been exhaustive, extended to every aspect of the Work in progress, or involved detailed inspections of the Work beyond the responsibilities specifically assigned to Engineer in the Contract Documents; or (ii) that there may not be other matters or issues between the parties that might entitle Contractor to be paid additionally by Municipalities or entitle Municipalities to withhold payment to Contractor.

**9.2.9** Neither Engineer's review of Contractor's Work for the purposes of recommending payments nor Engineer's recommendation of any payment, including final payment, will impose responsibility on Engineer to supervise, direct, or control the Work or for the



means, methods, techniques, sequences, or procedures of construction, or the safety precautions and programs incident thereto, or for Contractor's failure to comply with Laws and Regulations applicable to Contractor's performance of the Work. Additionally, said review or recommendation will not impose responsibility on Engineer to make any examination to ascertain how or for what purposes Contractor has used the moneys paid on account of the Contract Price, or to determine that title to any of the Work, materials, or equipment has passed to Municipalities free and clear of any Liens.

**9.2.10** Engineer may refuse to recommend the whole or any part of any payment if, in Engineer's opinion, it would be incorrect to make the representations to Municipalities referred to herein Engineer may also refuse to recommend any such payment or, because of subsequently discovered evidence or the results of subsequent inspections or tests, revise or revoke any such payment recommendation previously made, to such extent as may be necessary in Engineer's opinion to protect Municipalities from loss because:

**9.2.10.1** the Work is defective, or completed Work has been damaged, requiring correction or replacement;

**9.2.10.2** the Contract Price has been reduced by Written Amendment or Change Orders;

**9.2.10.3** Municipalities has been required to correct defective Work or complete Work in accordance with the Specifications; or

**9.2.10.4** Engineer has actual knowledge of the occurrence of any of the events warranting Contractor's termination for cause.

### **9.3 PAYMENT TO THE CONTRACTOR**

**9.3.1** Payment to the Contractor shall become due in accordance with the Municipalities' approval and payment schedule, but not later than thirty (30) days after presentation of the Application for Payment to Municipalities with Engineer's recommendation of the amount for payment (subject to the provisions contained herein) and will be paid by Municipalities to Contractor.

### **9.4 REDUCTION IN PAYMENTS**

**9.4.1** Reduction in payments recommended by the Engineer may be made by the Municipalities when:

**9.4.1.1** Claims have been made against Municipalities on account of Contractor's performance or furnishing of the Work;

**9.4.1.2** Liens have been filed in connection with the Work, except where Contractor has delivered a specific Bond satisfactory to Municipalities to secure the satisfaction and discharge of such Liens;

**9.4.1.3** there are other items entitling Municipalities to a set-off against the amount recommended; or

**9.4.1.4** Municipalities have actual knowledge of the occurrence of any of the events enumerated in Article 9.1.

#### **9.4.2 Liquidated Damages.**

**9.4.2.1** If the Contractor fails to complete the Work within the time specified in the Contract, or any extension, the Contractor shall pay to the Municipalities liquidated damages, as indicated in the contract for each day of delay. If different completion dates are specified in the Contract for separate parts or stages of the Work, the amount of liquidated damages shall be assessed on those parts or stages which are delayed. To the extent that the Contractor's delay or nonperformance is excused under another clause in this Contract, liquidated damages shall not be due the Municipalities. The Contractor remains liable for damages caused other than by delay.

**9.4.2.2** If the Municipalities terminate the Contractor's right to proceed, the resulting damage will consist of liquidated damages until such reasonable time as may be required for final completion of the Municipalities work together with any increased costs occasioned the Municipalities in completing the Work.

**9.4.2.3** If the Municipalities do not terminate the Contractor's right to proceed, the resulting damage will consist of liquidated damages until the Work is completed or accepted.

### **9.5 PAYMENT FOR ALTERATIONS TO THE CONTRACT**

**9.5.1** The Contractor shall receive and accept compensation provided for in the Contract as full payment for furnishing all materials; for performing work under the Contract in a complete and acceptable manner; and for all risk, loss, damage, or expense arising out of the nature or prosecution of the work, subject to the provisions contained herein.

**9.5.2** When final approved quantities of work vary from the Contract quantities, the Contractor shall accept payment at the original Contract unit prices for the accepted quantities of work done, unless specified otherwise in this Contract.. No additional allowance will be considered unless approved by the Engineer.

**9.5.3** Differing Site Conditions, changes, and Extra Work approved in accordance with the terms herein will be paid as stipulated in 9.1.4 herein.

### **9.6 UNJUSTIFIED WITHHOLDING OF PAYMENT**

**9.6.1** If it is subsequently determined that Municipalities' refusal of payment was not justified, the amount previously withheld shall become due with the subsequent request for payment

**9.6.2** The Municipalities and/or Engineer shall not be liable to the Contractor for damages resulting from the incorrect withholding of a payment

## **9.7 WRITTEN NOTICE TO CONTRACTOR**

**9.7.1** If Municipalities refuses to make payment of the full amount recommended by Engineer, Municipalities must give Contractor immediate written notice (with a copy to Engineer) stating the reasons for such action and promptly pay Contractor any amount remaining after deduction of the amount so withheld. Municipalities shall promptly pay Contractor the amount so withheld, or any adjustment thereto agreed to by Municipalities and Contractor, when Contractor corrects to Municipalities' satisfaction the reasons for such action.

## **9.8 CONTRACTOR REPRESENTATIONS**

**9.8.1** Contractor warrants and guarantees that title to all Work, materials, and equipment covered by any Application for Payment, whether incorporated in the Project or not, will pass to Municipalities no later than the time of payment free and clear of all Liens.

## **9.9 SUBSTANTIAL COMPLETION**

**9.9.1** When substantially complete the Contractor shall notify Municipalities and Engineer in writing that the entire Work is substantially complete and request that Engineer issue a certificate of Substantial Completion. Promptly thereafter, Municipalities, Contractor, and Engineer shall make an inspection of the Work to determine the status of completion. If Engineer does not consider the Work substantially complete, Engineer will notify Contractor in writing giving the reasons therefore. If Engineer considers the Work substantially complete, Engineer will prepare and deliver to Municipalities a tentative certificate of Substantial Completion which shall fix the date of Substantial Completion. There shall be attached to the certificate a tentative list of items to be completed or corrected before final payment. Municipalities shall have seven days after receipt of the tentative certificate during which to make written objection to Engineer as to any provisions of the certificate or attached list. If, after considering such objections, Engineer concludes that the Work is not substantially complete, Engineer will within 14 days after submission of the tentative certificate to Municipalities notify Contractor in writing, stating the reasons therefore. If, after consideration of Municipalities' objections, Engineer considers the Work substantially complete, Engineer will within said 14 days execute and deliver to Municipalities and Contractor a definitive certificate of Substantial Completion (with a revised tentative list of items to be completed or corrected) reflecting such changes from the tentative certificate as Engineer believes justified after consideration of any objections from Municipalities. At the time of delivery of the tentative certificate of Substantial Completion Engineer will deliver to Municipalities and Contractor a written recommendation as to division of responsibilities pending final payment between Municipalities and Contractor with respect to security, operation, safety, and protection of the Work, maintenance, heat, utilities, insurance, and warranties and guarantees. Unless Municipalities and Contractor agree otherwise in writing

and so inform Engineer in writing prior to Engineer's issuing the definitive certificate of Substantial Completion, Engineer's aforesaid recommendation will be binding on Municipalities and Contractor until final payment.

## **9.10 FINAL INSPECTION**

**9.10.1** A final inspection shall be performed by the Engineer upon written notice from Contractor that the entire Work or an agreed portion thereof is complete. The Municipalities and Contractor shall attend the Engineer's inspection and Engineer shall promptly notify Contractor in writing of all particulars in which this inspection reveals that the Work is incomplete or defective. Contractor shall immediately take such measures as are necessary to complete such Work or remedy such deficiencies.

## **9.11 FINAL PAYMENT**

**9.11.1** Final payment shall be made to the Contractor after, in the opinion of Engineer, the Contractor has satisfactorily completed all corrections identified during the final inspection and has delivered, in accordance with the Contract Documents, all maintenance and operating instructions, schedules, guarantees, Bonds, certificates or other evidence of insurance certificates of inspection, marked-up record documents, and other documents.

## **9.12 PROGRESS PAYMENTS**

**9.12.1** Contractor may make application for final payment in accordance with the procedure for progress payments:

**9.12.2** The final Application for Payment shall be accompanied (except as previously delivered) by: (i) all documentation called for in the Contract Documents, including but not limited to the evidence of insurance required herein; (ii) consent of the surety, if any, to final payment; and (iii) complete and legally effective releases or waivers (satisfactory to Municipalities) of all Lien rights arising out of or Liens filed in connection with the Work.

**9.12.3** In lieu of the releases or waivers of Liens specified herein and as approved by Municipalities, Contractor may furnish receipts or releases in full and an affidavit of Contractor that: (i) the releases and receipts include all labor, services, material, and equipment for which a Lien could be filed; and (ii) all payrolls, material and equipment bills, and other indebtedness connected with the Work for which Municipalities or Municipalities' property might in any way be responsible have been paid or otherwise satisfied. If any Subcontractor or Supplier fails to furnish such a release or receipt in full, Contractor may furnish a Bond or other collateral satisfactory to Municipalities to indemnify Municipalities against any Lien.

## **9.13 ACCEPTANCE OF WORK BY ENGINEER**

**9.13.1** If, on the basis of Engineer's observation of the Work during construction and final inspection, and Engineer's review of the final Application for Payment and accompanying documentation as required by the Contract Documents, Engineer is satisfied that the Work has been completed and Contractor's other obligations under the Contract Documents have been fulfilled, Engineer will, within ten days after receipt of the final Application for Payment, indicate in writing Engineer's recommendation of payment and present the Application for Payment to Municipalities for payment. At the same time Engineer will also give written notice to Municipalities and Contractor that the Work is acceptable subject to the provisions contained herein. Otherwise, Engineer will return the Application for Payment to Contractor, indicating in writing the reasons for refusing to recommend final payment, in which case Contractor shall make the necessary corrections and resubmit the Application for Payment.

## **9.14 ADJUSTMENTS TO FINAL PAYMENT**

**9.14.1** When an item of work is designated as a final pay quantity in the Method of Measurement, Basis of Payment, and Bid Schedule (F), the estimated bid quantity for that item of work shall be the final pay quantity, unless the dimensions of any portion or the quantity of that item are revised by the Engineer, or the item or any portion of the item is eliminated. If the dimensions of any portion or the quantity of the item are revised, and the revision results in an increase or decrease in the estimated quantity of that item of work, the final pay quantity for the item will be revised in the amount represented by the changes in the dimensions or the quantity. If a final pay item is eliminated, the estimated quantity for the item will be eliminated. If a portion of a final pay item is eliminated, the final pay quantity will be revised in the amount represented by the eliminated portion of the item of work.

The estimated quantity for each item of work designated as a final pay quantity in the Method of Measurement and Basis of Payment shall be considered as approximate only, and no guarantee is made that the quantity which can be determined by computations, based on the details and dimensions shown on the plans, will equal the estimated quantity. No adjustment will be made in the event that the quantity based on computations does not equal the estimated quantity.

The Contractor may review the computations of final pay quantity items on record at the Municipalities. The computations requested will be available within one week after a request is received by the contact person stated in the Invitation for Bids. In case of discrepancy between the quantity shown in the Bid Schedule for a final pay item and the quantity or summation of quantities for the same item shown on the plans, payment will be based on the quantity shown in the Bid Schedule.

## **ARTICLE 10 - MISCELLANEOUS**

### **10.1 WRITTEN NOTICE**

**10.1.1** Whenever any provision of the Contract requires the giving of written notice, it will be deemed to have been validly given if delivered in person to the individual or to a member of the firm or to an officer of the corporation for whom it is intended, or if delivered at or sent by registered or certified mail, postage prepaid, to the last business address known to the giver of the notice.

**10.1.2** When any period of time is referred to in the Contract Documents by days, it will be computed to exclude the first and include the last day of such period. If the last day of any such period falls on a Saturday or Sunday or on a day made a legal holiday by the law of the applicable jurisdiction, such day will be omitted from the computation.

### **10.2 CUMULATIVE REMEDIES**

**10.2.1** The duties and obligations imposed by these General Conditions and the rights and remedies available hereunder to the parties hereto are in addition to, and are not to be construed in any way as a limitation of, any rights and remedies available to any or all of them which are otherwise imposed or available by Laws or Regulations, by special warranty or guarantee, or by other provisions of the Contract Documents, and the provisions of this paragraph will be as effective as if repeated specifically in the Contract Documents in connection with each particular duty, obligation, right, and remedy to which they apply.

### **10.3 SURVIVAL OBLIGATIONS**

**10.3.1** All representations, indemnifications, warranties, and guarantees made in, required by, or given in accordance with the Contract Documents, as well as all continuing obligations indicated in the Contract Documents, will survive final payment, completion, and acceptance of the Work or termination or completion of the Agreement.

### **10.4 CONTROLLING LAW**

**10.4.1** This Contract is to be governed by the laws of the state in which the Project is located.

### **10.5 PROJECT VISITATION BY THIRD PARTY**

**10.5.1** Non-emergency visits by third party requires 24-hour notice to Contractor and Engineer. The Contractor must provide applicable contact name and phone number of desired point of contact. If the primary contact is unavailable, an appropriate voice message must be provided describing an alternate contact person and phone number.



# Site Improvement Plans Freedom Field



## June 12, 2020

THIS PLAN SET  
LAST REVISED ON:  
3/24/2023

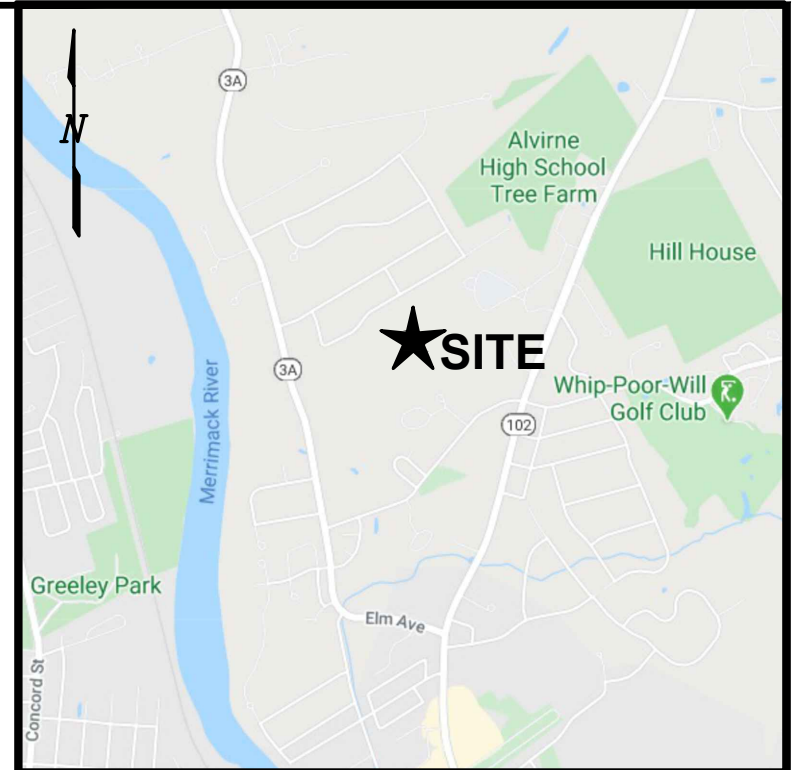

### LOCATION PLAN

PREPARED FROM:  
GOOGLE MAPS  
SCALE: 1" = 1/2 MILE (2640 FEET)

### NOTE

THIS PLAN WAS PREPARED FROM THE ASSESSORS MAPS  
OF THE TOWN OF HUDSON.

### LEGEND

	EXISTING	PROPOSED
EDGE OF GRAVEL		
PROPERTY LINE		
IRON ROD		
GRANITE BOUND		
TEMPORARY BENCH MARK		
CONTOURS		
SPOT ELEVATIONS		
SOILS BOUNDARY		
SCS SOIL IDENTIFICATION SYMBOL		
TREE LINE		
EVERGREEN TREE		
ROCK		
CHAIN LINK FENCE		
SILTATION SOCK		
PIPE FLOW ARROWS		
DRAIN PIPE		
CLEAN OUT		
DRAINAGE FLOW ARROWS		
ELECTRIC MANHOLE		
IRRIGATION CONTROL VALVE		
DRILLED WELL		
TEST HOLE		

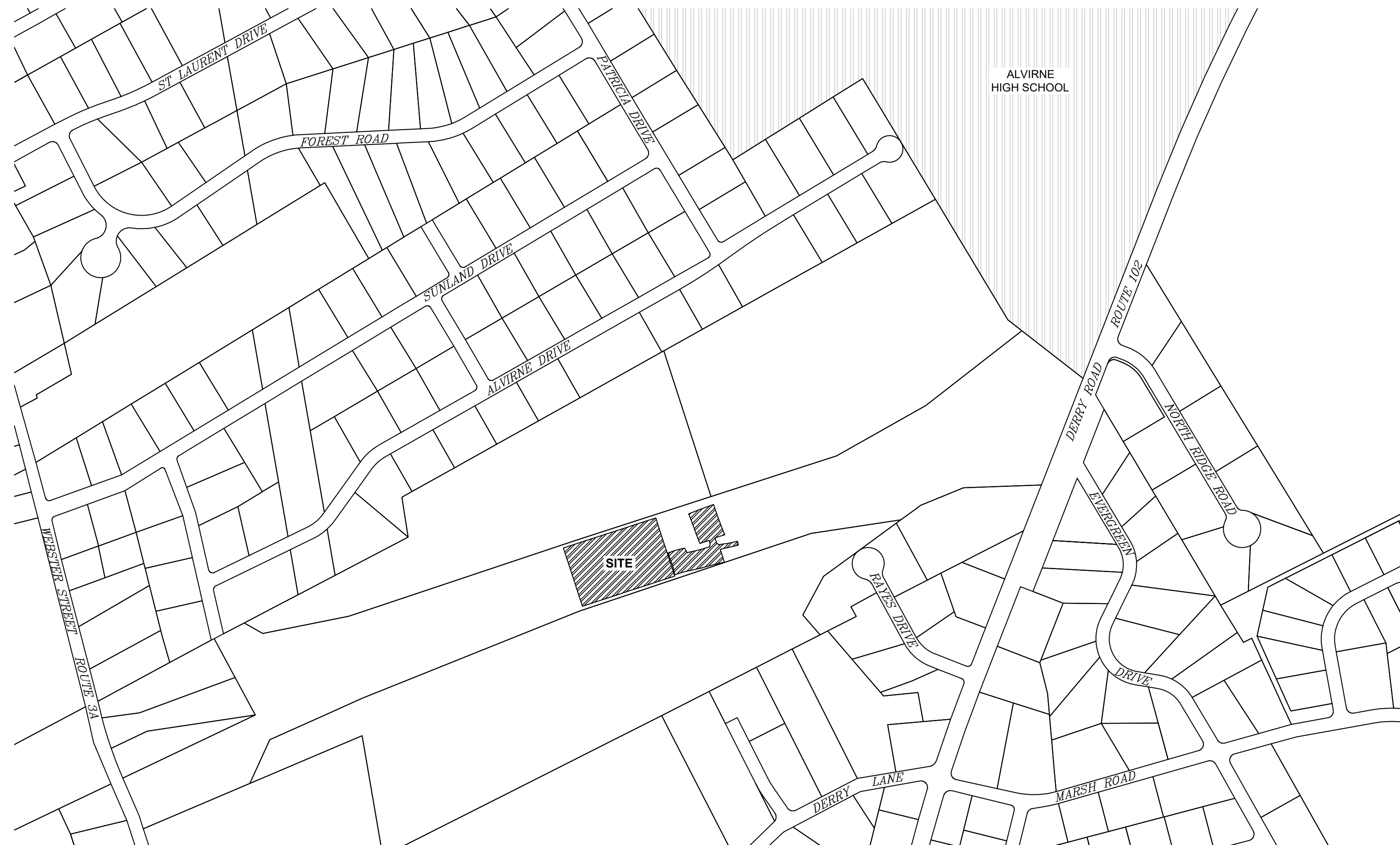

### SHEET INDEX

SHEET NUMBER	DESCRIPTION	REVISION NUMBER	DATE
1	TITLE SHEET	4	3/24/2023
2	EXISTING CONDITIONS PLAN	2	2/7/2022
3	SITE IMPROVEMENT PLAN	2	3/24/2023
4	PROFILE & CROSS SECTION PLAN	2	3/24/2023
5	CONSTRUCTION DETAILS	3	3/24/2023

4	Revised Sheet Index	3/24/2023
3	Revised Sheet Index	6/16/2022
2	Revised Sheet Index	2/7/2022
1	Revised Sheet Index	3/1/2021
No.	Revision	Date
Designed by: JRB		Drawn by: JRB
		Checked by: DMF



DIG SAFE 1-888-344-7233

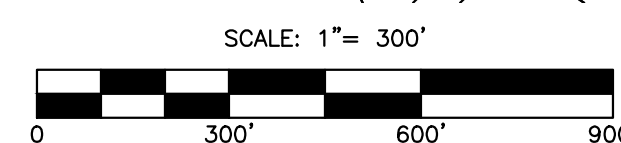

Title Sheet  
**Town of Hudson - Freedom Field**  
**194 Derry Road**  
**Hudson, NH**  
Assessors Map 138 Lot 89

183 Rockingham Rd, Unit 3 East  
Windham, NH 03087

**SFC**  
ENGINEERING

(603) 647-8700  
www.sfceing.com

Sheet 1 of 5      Scale: 1" = 300'      Date: 6/12/2020

DANIEL  
M.  
FLORES  
No. 15761  
LICENSED  
PROFESSIONAL ENGINEER

Prepared for:  
Town of Hudson  
12 School Street  
Hudson, NH 03051

Zoning Classification: Residential 1 & Residential 2



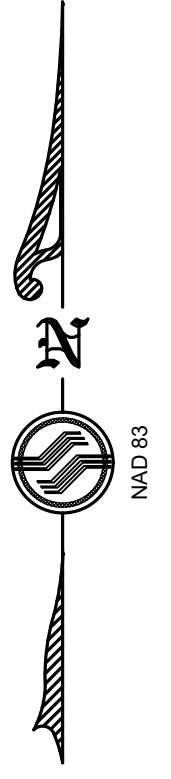

**PLANS OF REFERENCE**

1. KEACH-NORDSTROM ASSOCIATES, INC., FREEDOM FIELD - SURVEY BASE PLAN WITH CONTROL AND APPROXIMATE PROPERTY LINES.
2. TOWN OF HUDSON, FREEDOM FIELD 2' PLAN SET, PREPARED BY: TOWN OF HUDSON TOWN ENGINEER - ELVIS DHIMA, PE, DATED: APRIL 2017.

**NOTES**

1. THE PURPOSE OF THIS PLAN IS TO DEPICT THE EXISTING CONDITIONS OF THE MULTIUSE ATHLETIC FIELD ON A PORTION OF HUDSON PROPERTY MAP 138 LOT 89.
2. THE OWNER OF RECORD: TOWN OF HUDSON
3. NO PORTION OF THIS PARCEL IS LOCATED WITHIN A FLOOD HAZARD AREA AS INTERPRETED FROM THE FLOOD INSURANCE RATE MAP FOR THE TOWN OF HUDSON, COMMUNITY-PANEL NUMBER 3301C0152D, EFFECTIVE DATE: 9/25/2009 PREPARED BY THE FEDERAL EMERGENCY MANAGEMENT AGENCY.
4. NO UNDERGROUND UTILITY LOCATIONS ARE SHOWN. CONTRACTOR TO CONTACT DIGSAFE 72 HOURS PRIOR TO CONSTRUCTION.
5. NO WETLAND DELINEATION / MAPPING WAS PERFORMED.
6. THIS PLAN SHOWS CONDITIONS AS DEFINED BY INSTRUMENT FIELD SURVEY ON 4/1/2020. THIS PLAN DOES NOT REPRESENT A BOUNDARY SURVEY BY SFC ENGINEERING PARTNERSHIP, INC.
7. BENCHMARK: CHC 900  
VERTICAL DATUM: NAVD 88  
HORIZONTAL DATUM: NAD 83
8. TEST HOLE LOCATIONS TP#1 THROUGH TP#6 ARE APPROXIMATE FROM GSI FIELD INVESTIGATION AND GUELPH PERMEAMETER TESTING REPORT DATED DECEMBER 4, 2019. SEE REPORT FOR COMPLETE SOIL PROFILE LOGS.
9. PREDOMINATE SOILS IN THE AREA OF SURVEY ARE HINCKLEY (HsC) LOAMY SAND AND PIPESTONE (PiA) LOAMY SAND TAKEN FROM NRCS WEB SOIL SURVEY.
10. TEST HOLES 'A' - 'D' WERE OBSERVED BY SFC ON MARCH 1, 2021.
11. TEST HOLES TP21-1 THROUGH TP21-8 WERE OBSERVED BY SFC ON AUGUST 17, 2021 FOR THE PURPOSE OF ESTIMATING TOPSOIL AND GRAVEL FILL.

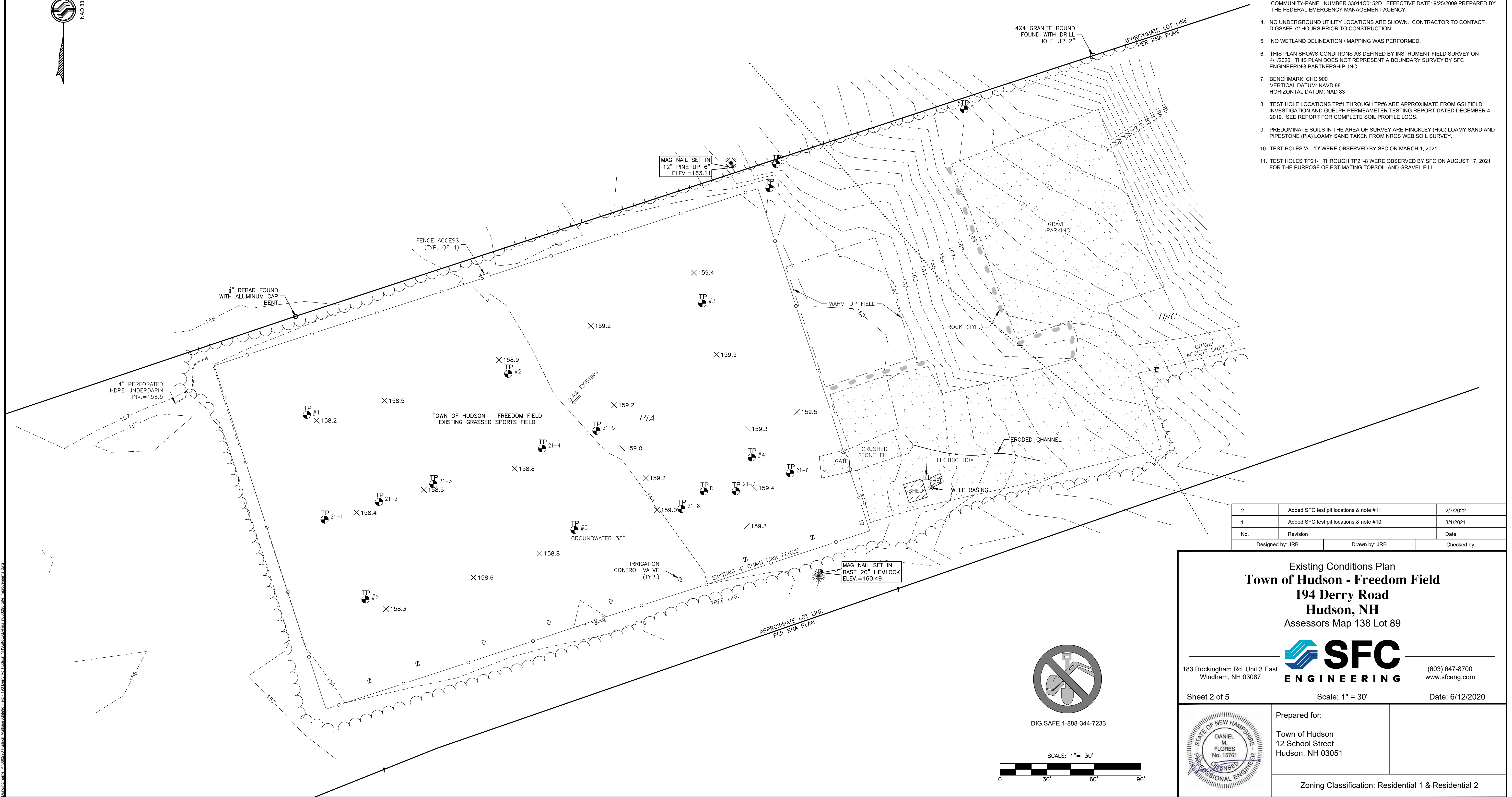

2	Added SFC test pit locations & note #11	2/7/2022
1	Added SFC test pit locations & note #10	3/1/2021
No.	Revision	Date
Designed by: JRB		Drawn by: JRB
Checked by:		

Existing Conditions Plan  
**Town of Hudson - Freedom Field**  
 194 Derry Road  
 Hudson, NH  
 Assessors Map 138 Lot 89

183 Rockingham Rd, Unit 3 East  
 Windham, NH 03087 (603) 647-8700  
 www.sfceing.com

Sheet 2 of 5      Scale: 1" = 30'      Date: 6/12/2020

Prepared for:  
 Town of Hudson  
 12 School Street  
 Hudson, NH 03051

Zoning Classification: Residential 1 & Residential 2

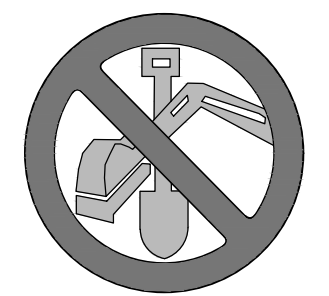

DIG SAFE 1-888-344-7233

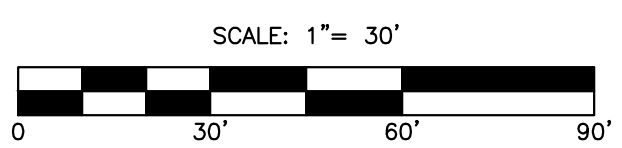

SCALE: 1" = 30'



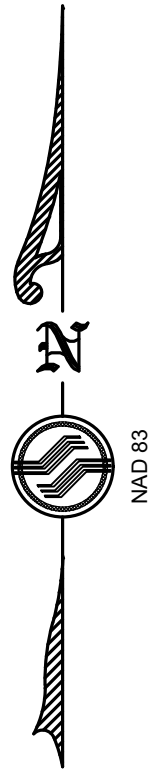

**NOTES**

1. THE PURPOSE OF THIS PLAN IS TO DEPICT THE PROPOSED MULTIUSE ATHLETIC FIELD IMPROVEMENTS ON HUDSON PROPERTY MAP 138 LOT 89.
2. OWNER OF RECORD: TOWN OF HUDSON
3. PROPOSED IMPROVEMENTS INCLUDE:
  - A. STRIP VEGETATION FROM EXISTING TOPSOIL.
  - B. SHAPE EXISTING TOPSOIL LOAM TO ACHIEVE DESIGN CROWN.
  - C. RAISE PLAYING FIELD TO PROPOSED ELEVATION WITH SPECIFIED SOILS.
  - D. INSTALL INTERCEPTOR DRAINS.
  - E. INTRODUCE DITCHES ALONG NORTH AND SOUTH SIDE OF FIELD.
  - F. RESETTING OF CHAIN LINK FENCE AROUND FIELD PERIMETER.
  - G. REGRADE PRACTICE FIELD.
  - H. REGRADE ACCESS DRIVE TO DIVERT STORMWATER AWAY FROM FIELD.
  - I. CONSTRUCT SWALE ALONG EXISTING GRAVEL PARKING AREA.
4. TOTAL LAND AREA DISTURBED WITH THIS PROJECT: 136,000± SF
5. SFC ENGINEERING PARTNERSHIP, INC. DOES NOT WARRANT THE LOCATION OR ELEVATION OF THE EXISTING UTILITIES OR THAT ALL ARE SHOWN. CONTRACTOR SHALL BE RESPONSIBLE FOR CONTACTING DIG SAFE (1-800-384-7233) AT LEAST 72 HOURS PRIOR TO CONSTRUCTION IN ACCORDANCE WITH STATE LAW.
6. ALL WORK SHALL CONFORM TO THE TOWN OF HUDSON STANDARDS.
7. SEE EXISTING CONDITIONS PLAN FOR DATUM INFORMATION.
8. PRIOR TO CONSTRUCTION THE CONTRACTOR SHALL VERIFY THAT THEY HAVE THE MOST RECENT SET OF PLANS. ALL WORK SHALL BE PERFORMED USING A COMPLETE SET OF PLANS AS SOME ITEMS ARE NOT SHOWN ON EVERY SHEET.
9. THE ENGINEER SHALL BE NOTIFIED IMMEDIATELY IF CONDITIONS ARE FOUND THAT DO NOT MATCH WHAT IS SHOWN ON THESE PLANS.
10. INSTALL EROSION AND SEDIMENT CONTROL BARRIER IN STORMWATER RUNOFF PATHS BETWEEN ANY DISTURBED AREAS AND PROPERTY LINES OR WETLAND BUFFERS. REFER TO THE CURRENT EDITION OF "NHDOT GUIDELINES FOR TEMPORARY EROSION CONTROL & SEDIMENT CONTROL & STORMWATER MANAGEMENT" FOR DETAILS.
11. CHAINLINK FENCE SHALL BE REPLACED IN SAME LOCATION.
12. THE IRRIGATION SYSTEM SHALL BE REPLACED PER TOWN REQUIREMENTS.
13. 210' x 345' PLAYING FIELD AND 60' x 100' PRACTICE FIELD SHALL HAVE SOIL SECTION AS SHOWN ON DETAIL SHEET. ALL OTHER DISTURBED AREAS SHALL HAVE 4" OF LOAM AND SEEDED, UNLESS NOTED OTHERWISE.
14. FEDERAL CONSTRUCTION GENERAL PERMIT: THE OWNER, IN CONJUNCTION WITH THE CONTRACTOR (OPERATORS), IS REQUIRED TO FILE A NOTICE OF INTENT (NOI) FOR COVERAGE UNDER THE FEDERAL CONSTRUCTION GENERAL PERMIT (CGP) FOR SMALL CONSTRUCTION ACTIVITIES (GREATER THAN ONE ACRE BUT LESS THAN FIVE ACRES) FROM THE ENVIRONMENTAL PROTECTION AGENCY (EPA). THE NOI WILL NEED TO BE FILED 14 DAYS PRIOR TO COMMENCING CONSTRUCTION. A STORM WATER POLLUTION PREVENTION PLAN (SWPPP) IS REQUIRED TO BE DEVELOPED PRIOR TO FILING THE NOI.

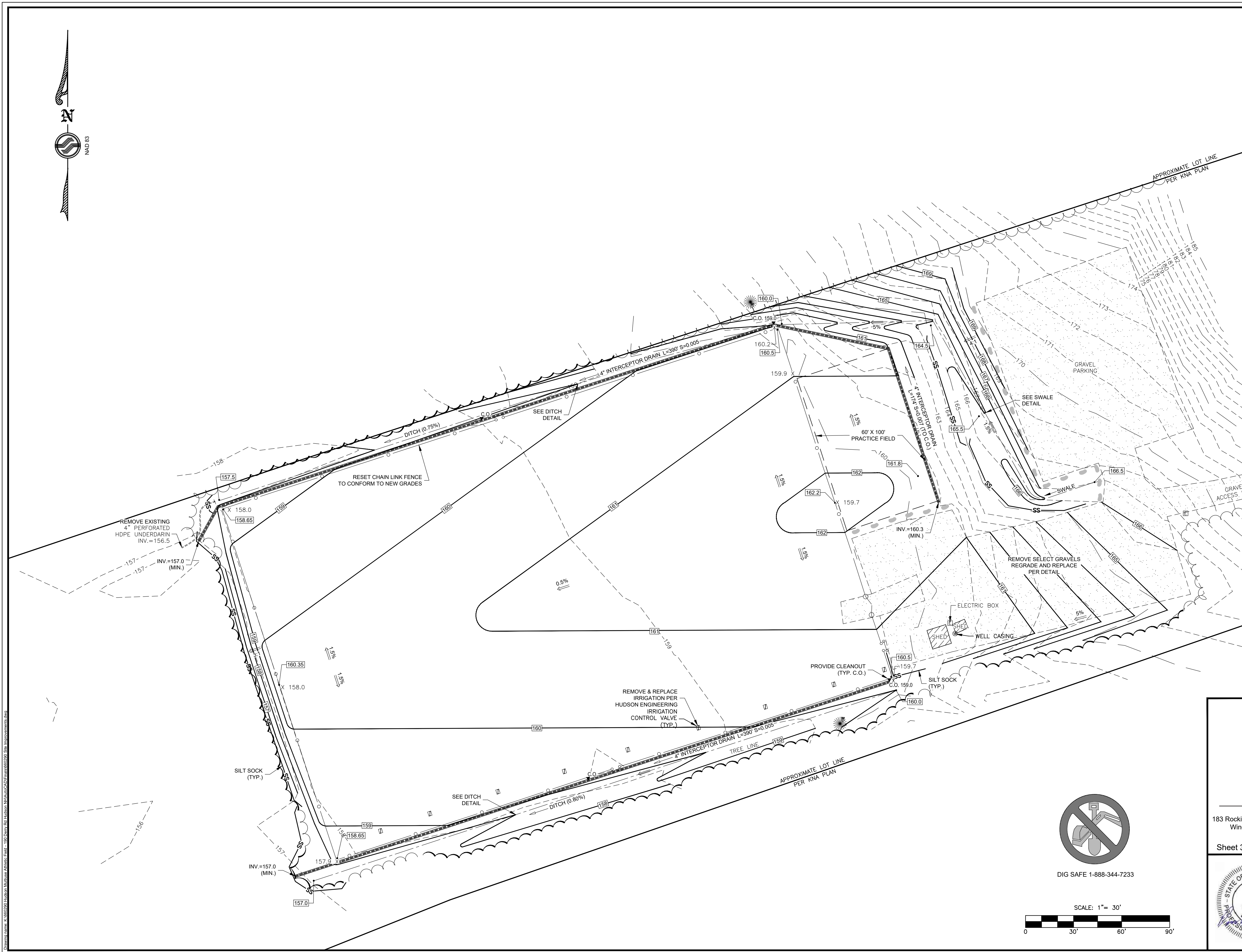

2	Revised note #3	3/24/2023
1	Revised note #3 and revised to remove underdrains	2/7/2022
No.	Revision	Date
Designed by: JRB		Drawn by: JRB
		Checked by: DMF

**Site Improvement Plan**  
**Town of Hudson - Freedom Field**  
**194 Derry Road**  
**Hudson, NH**  
 Assessors Map 138 Lot 89

183 Rockingham Rd, Unit 3 East  
Windham, NH 03087

(603) 647-8700  
www.sfeng.com

Sheet 3 of 5      Scale: 1" = 30'      Date: 6/12/2020

	Prepared for: Town of Hudson 12 School Street Hudson, NH 03051
Zoning Classification: Residential 1 & Residential 2	

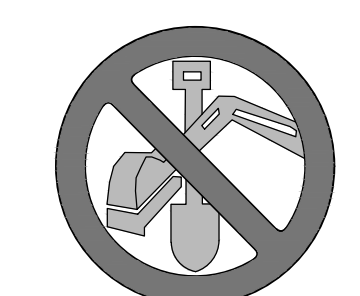

DIG SAFE 1-888-344-7233

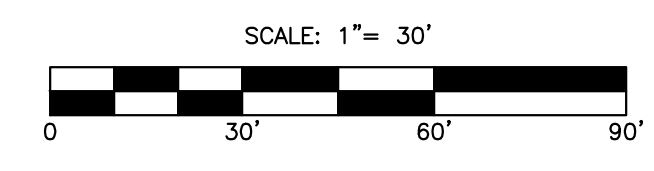



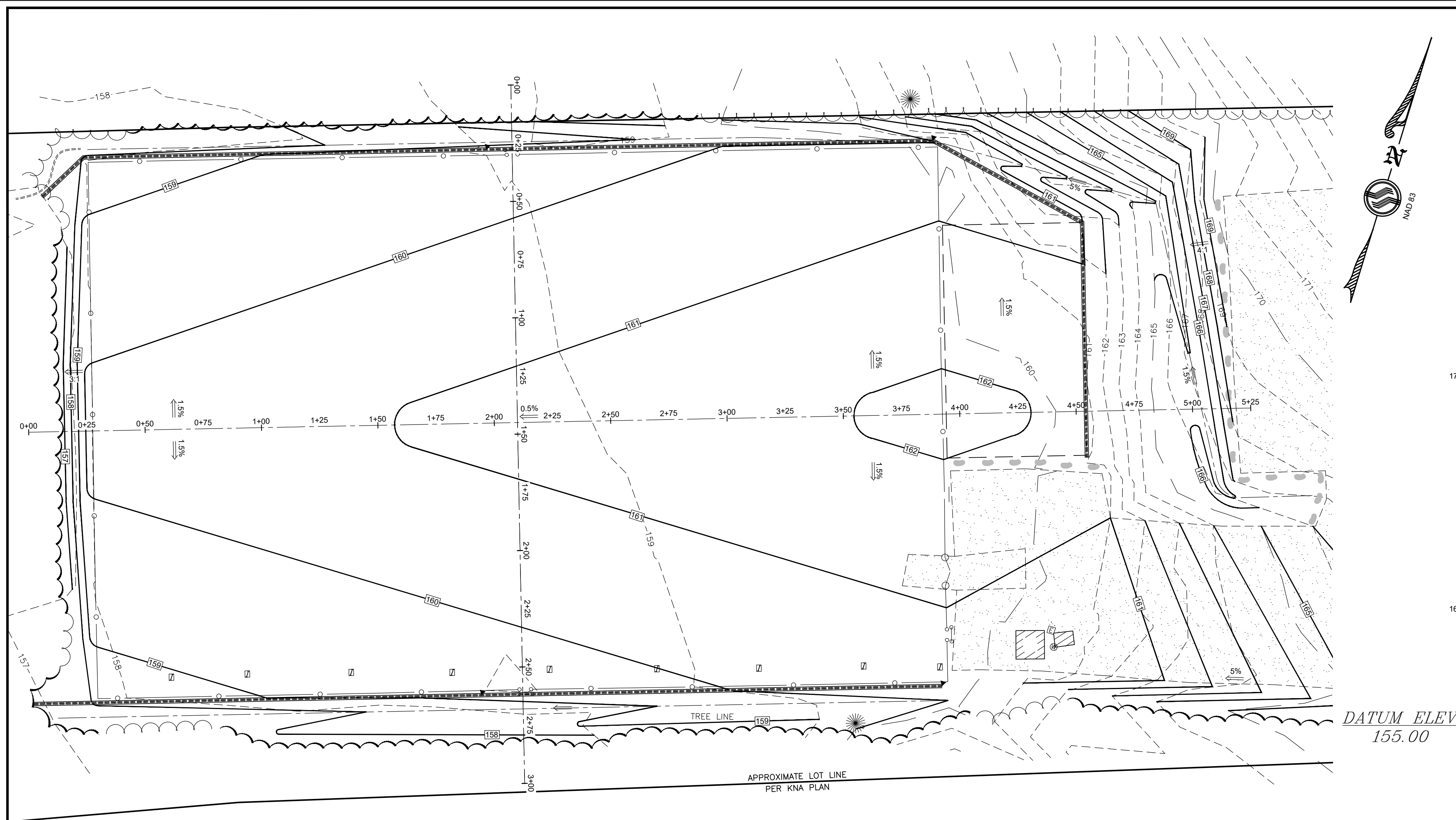

**NOTES**  
1. THE PURPOSE OF THIS PLAN IS TO DEPICT THE PROPOSED PROFILE AND CROSS SECTION IMPROVEMENTS TO THE MULTIUSE ATHLETIC FIELD ON A PORTION OF HUDSON PROPERTY MAP 138 LOT 89.

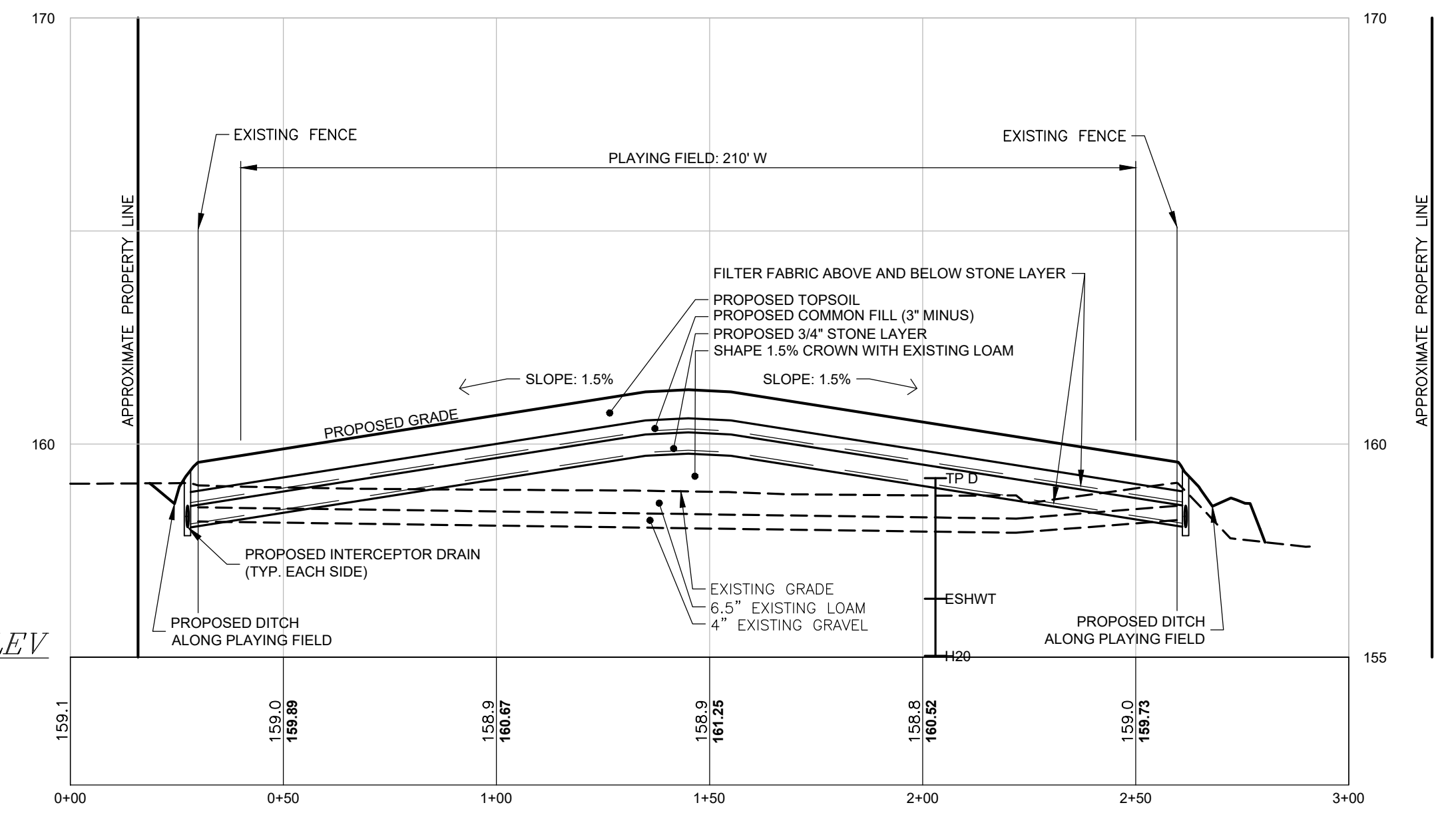

**PLAYING FIELD CROSS SECTION**

SCALE: 1" = 30' H 1" = 3' V  
SEE DETAILS SHEET FOR DEPTH OF SOIL LAYERS

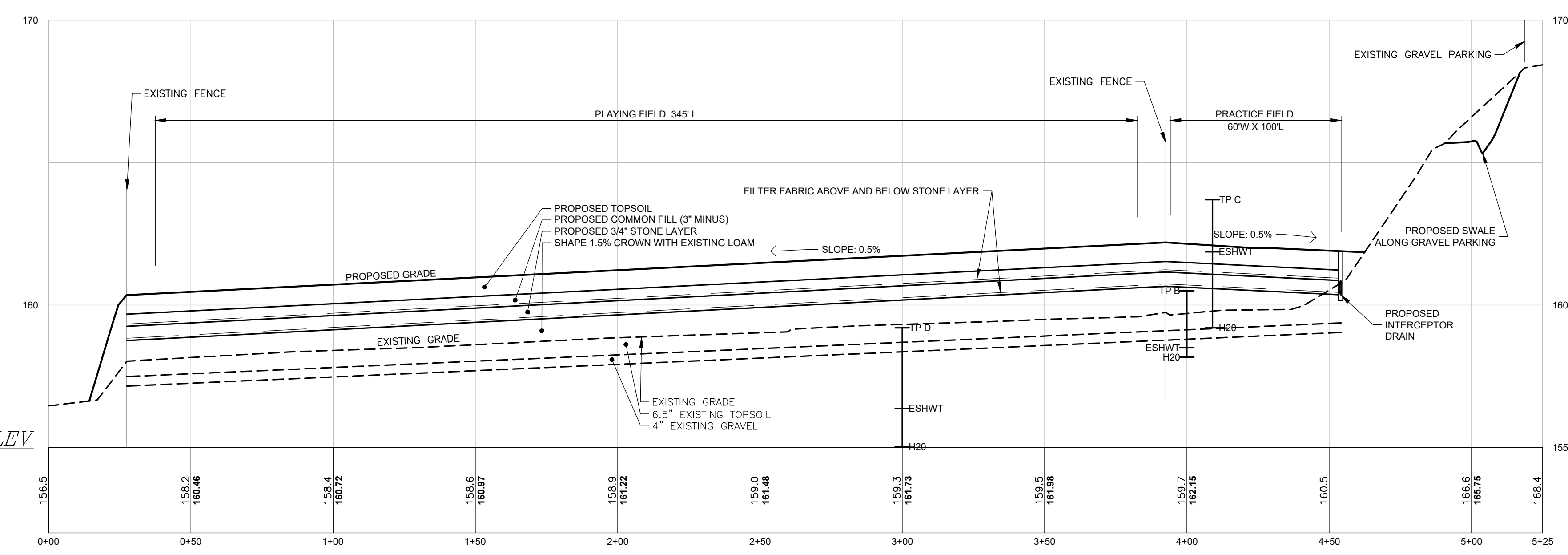

**PLAYING FIELD PROFILE**

SCALE: 1" = 30' H 1" = 3' V  
SEE DETAILS SHEET FOR DEPTH OF SOIL LAYERS



DIG SAFE 1-888-344-7233

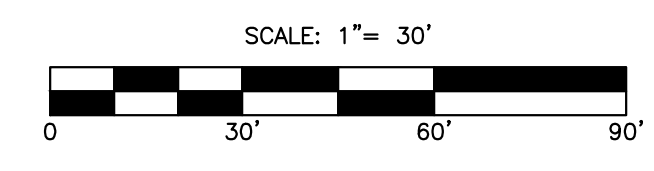

2	Revised stone layer and added filter fabric	3/24/2023
1	Removed note #2 and revised to remove underdrains	2/7/2022
No.	Revision	Date
Designed by: JRB		Checked by: DMF
Drawn by: JRB		Date

Profile & Cross Section Plan  
**Town of Hudson - Freedom Field**  
194 Derry Road  
Hudson, NH  
Assessors Map 138 Lot 89

**SFC ENGINEERING**

183 Rockingham Rd, Unit 3 East  
Windham, NH 03087 (603) 647-8700  
www.sfeng.com

Sheet 4 of 5 Scale: 1" = 30' Date: 6/12/2020

Prepared for:  
Town of Hudson  
12 School Street  
Hudson, NH 03051

Zoning Classification: Residential 1 & Residential 2

STATE OF NEW HAMPSHIRE  
DANIEL M. FLORES  
No. 15761  
LICENSED PROFESSIONAL ENGINEER



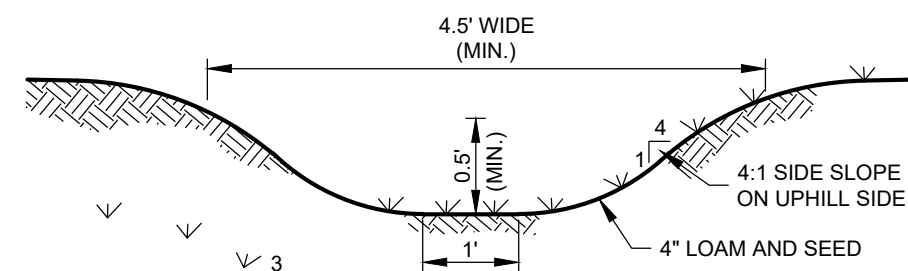

**MAINTENANCE REQUIREMENTS:**

1. LAND OWNER SHALL BE RESPONSIBLE FOR MAINTENANCE OF VEGETATED SWALE.
2. INSPECT ANNUALLY FOR EROSION, SEDIMENT ACCUMULATION, VEGETATION LOSS, AND PRESENCE OF INVASIVE SPECIES.
3. PERFORM PERIODIC MOWING; FREQUENCY DEPENDS ON LOCATION AND TYPE OF GRASS. DO NOT CUT SHORTER THAN 4-INCHES.
4. REMOVE DEBRIS AND ACCUMULATED SEDIMENT, BASED ON INSPECTION.
5. REPAIR ANY ERODED AREA, REMOVE INVASIVE SPECIES AND DEAD VEGETATION, AND RESEED WITH APPLICABLE GRASS MIX AS WARRANTED BY INSPECTION.

**SWALE DETAIL ALONG GRAVEL PARKING**

NOT TO SCALE  
TO BE CONSTRUCTED ALONG WEST SIDE OF PARKING (260 LF)

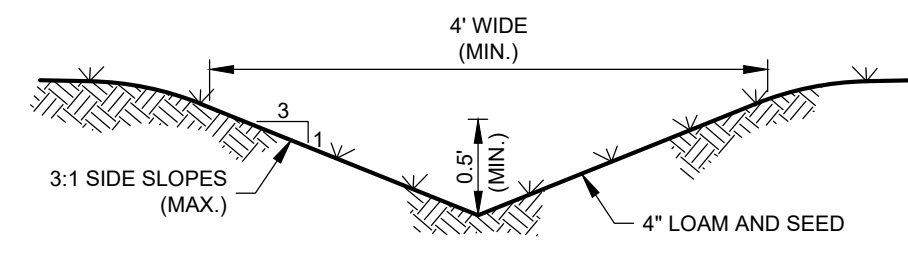

**MAINTENANCE REQUIREMENTS:**

1. LAND OWNER SHALL BE RESPONSIBLE FOR MAINTENANCE OF VEGETATED SWALE.
2. INSPECT ANNUALLY FOR EROSION, SEDIMENT ACCUMULATION, VEGETATION LOSS, AND PRESENCE OF INVASIVE SPECIES.
3. PERFORM PERIODIC MOWING; FREQUENCY DEPENDS ON LOCATION AND TYPE OF GRASS. DO NOT CUT SHORTER THAN 4-INCHES.
4. REMOVE DEBRIS AND ACCUMULATED SEDIMENT, BASED ON INSPECTION.
5. REPAIR ANY ERODED AREA, REMOVE INVASIVE SPECIES AND DEAD VEGETATION, AND RESEED WITH APPLICABLE GRASS MIX AS WARRANTED BY INSPECTION.

**DITCH DETAIL ALONG PLAYING FIELD**

NOT TO SCALE  
TO BE CONSTRUCTED AT NORTH AND SOUTH SIDES OF FIELD (740 LF)

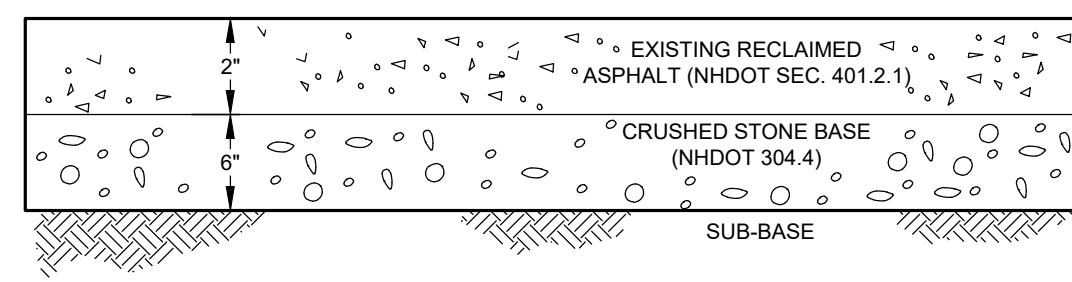

**GRAVEL DETAIL**

NOT TO SCALE  
TO BE USED IN RECONSTRUCTED PARKING/ACCESS DRIVE AREAS

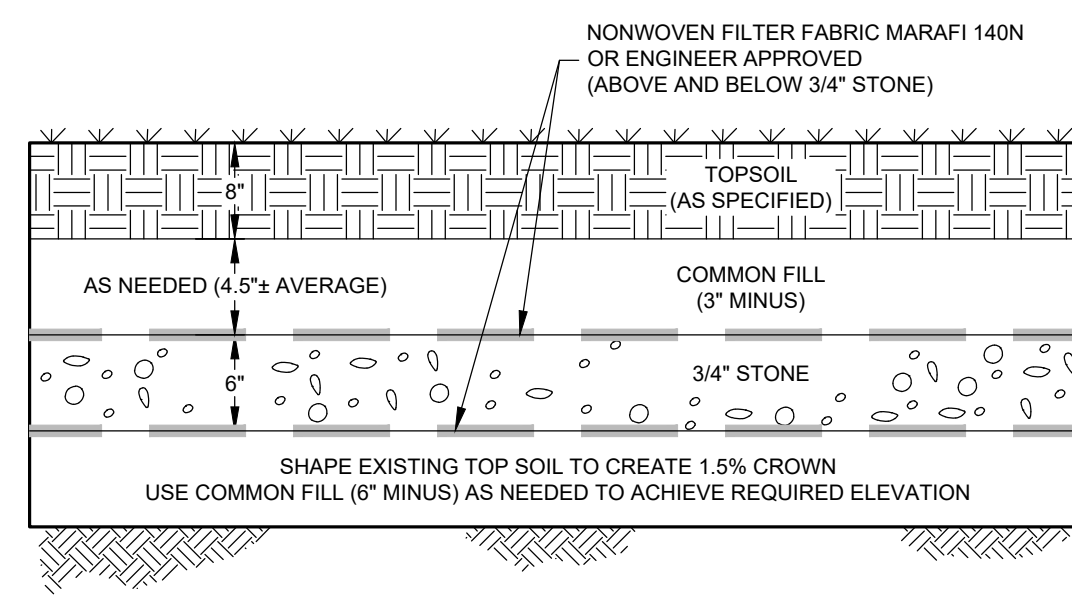

**PLAYING FIELD SOIL PROFILE**

NOT TO SCALE  
EACH SOIL LAYER IS TO MATCH SPECIFIED 1.5% CROWN  
ALL VEGETATION IS TO BE REMOVED FROM EXISTING TOPSOIL BEFORE SHAPING

**TOPSOIL SPECIFICATION**

MINIMUM & MAXIMUM pH: 5.5 TO 7.6  
ORGANIC MATTER CONTENT: 3% TO 10%

TOP SOIL SHALL MEET THE FOLLOWING GRADATION:

SIEVE SIZE	PERCENT PASSING
#4	100
#10	90 - 100
#20	67 - 87
#40	35 - 52
#100	7 - 15
#200	< 10

**3/4" STONE SPECIFICATION**

STONE TO MEET REQUIREMENTS FOR "SEPTIC STONE"  
PER ENV-WQ 1016.04 TABLE 1016-2

SIEVE SIZE	PERCENT PASSING
2 INCH	100
1.5 INCH	90 - 100
3/4 INCH	0 - 20
#4	0 - 5

**COMMON FILL SPECIFICATION**

MATERIAL MUST BE WELL GRADED, FREE DRAINING WITH NOT MORE THAN 20% PASSING #200 SIEVE AND NO MATERIAL SIZE GREATER THAN SPECIFIED ABOVE.  
MATERIAL TO BE FREE OF ORGANICS.

**NOTES**

1. ALL MATERIAL TO MEET FILTREXX™ SPECIFICATIONS.
2. THE CONTRACTOR SHALL MAINTAIN THE COMPOST FILTER BERM IN A FUNCTIONAL CONDITION AT ALL TIMES AND IT SHALL BE ROUTINELY INSPECTED.
3. WHERE THE BERM REQUIRES REPAIR, IT WILL BE ROUTINELY REPAIRED.
4. THE CONTRACTOR SHALL REMOVE SEDIMENTS COLLECTED AT THE BASE OF THE BERM WHEN THEY REACH 1/3 OF THE EXPOSED HEIGHT OF THE BERM, OR AS DIRECTED BY THE ENGINEER.
5. THE COMPOST FILTER BERM WILL BE DISPERSED ON SITE WHEN NO LONGER REQUIRED, AS DETERMINED BY THE ENGINEER.

**SOCK OPTION:**

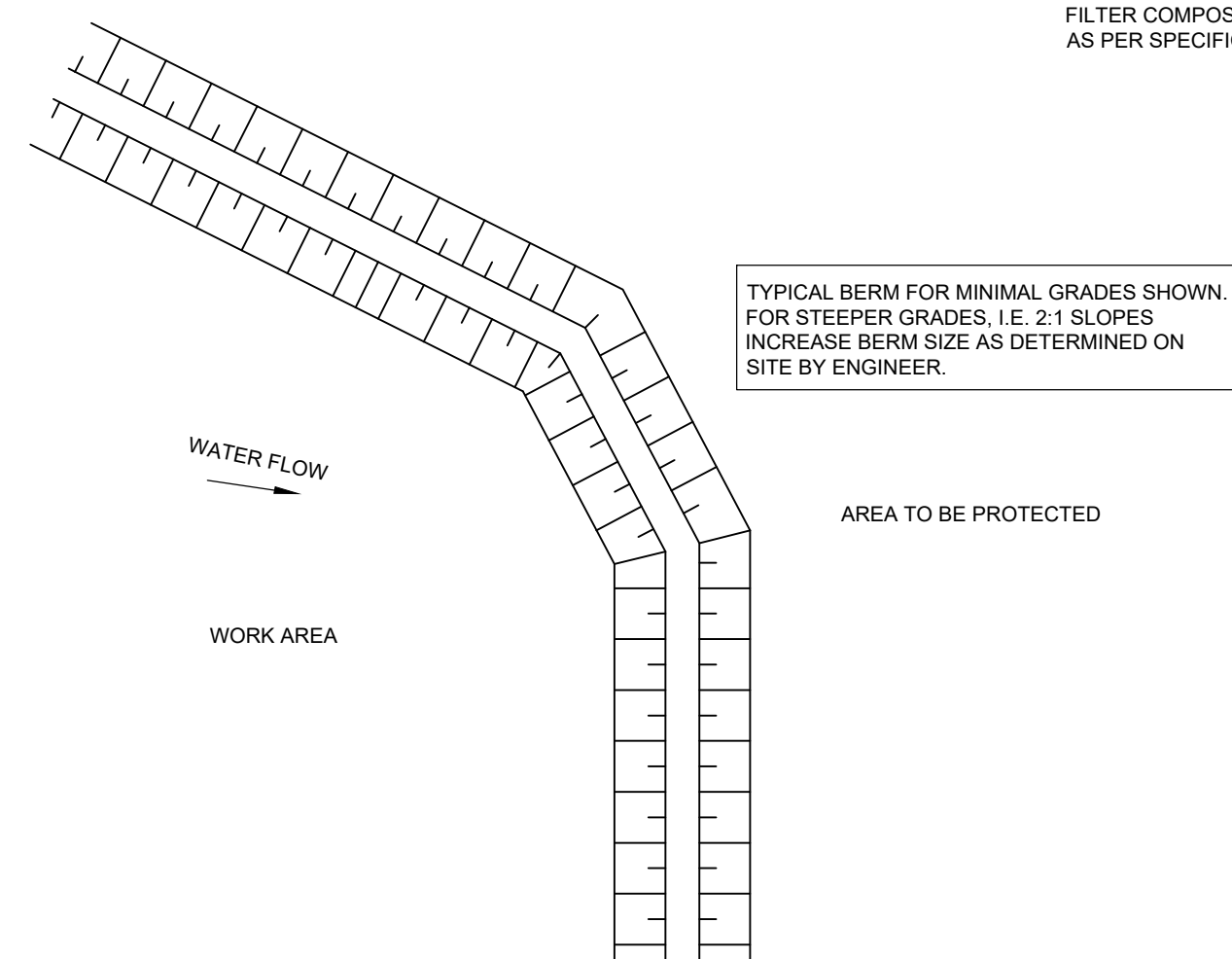
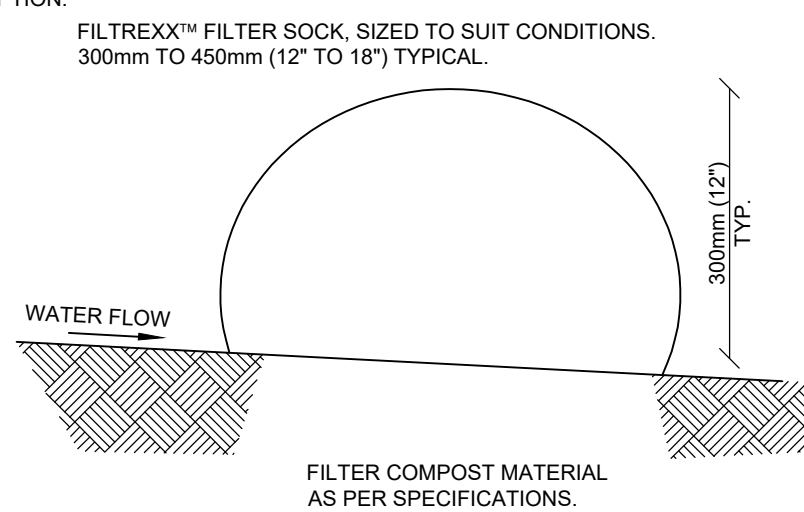

**SILT SOCK INSTALLATION DETAIL**

NOT TO SCALE  
INSTALL 225 LINEAR FEET

**CONSTRUCTION SEQUENCE**

1. INSTALL PERIMETER EROSION CONTROL MEASURES. TEMPORARY EROSION AND SEDIMENT CONTROL PRACTICES SHALL BE INSTALLED PRIOR TO ANY EARTH MOVING OPERATION. EROSION CONTROL MEASURES SHALL BE INSTALLED AS SHOWN ON THE PLANS AND SHALL CONFORM TO ALL APPLICABLE SECTIONS OF THE NEW HAMPSHIRE STORMWATER MANUAL, DECEMBER 2008.
2. CUT AND CLEAR TREES. IDENTIFY TREES TO BE SAVED AND INSTALL PROTECTIVE FENCES AROUND THESE TREES. CUT TREES, CLEAR AND DISPOSE OF DEBRIS.
3. INSTALL OTHER EROSION CONTROL MEASURES. TEMPORARY AND PERMANENT EROSION, SEDIMENT AND DETENTION PRACTICES - INCLUDING PONDS AND SWALES - SHALL BE INSTALLED PRIOR TO ROUGH GRADING. PERMANENT STORMWATER TREATMENT SYSTEMS ARE TO BE CONSTRUCTED AND SEEDED AS SOON AS PRACTICAL, SO THAT VEGETATION MAY BE ESTABLISHED PRIOR TO DIRECTING RUNOFF TO THEM. ADDITIONAL STORMWATER MANAGEMENT PRACTICES SHALL BE IMMEDIATELY INSTALLED WHEN NECESSARY AND APPROPRIATE DURING CONSTRUCTION.
4. PROTECT DRAINAGE STRUCTURES. DURING CONSTRUCTION, ALL DRAINAGE INLETS SHALL BE PROTECTED BY INSTALLING A GEOTEXTILE BARRIER UNDER THE GRATE OR BY INSTALLING A STONE CHECK DAM AROUND THE PERIMETER OF THE GRATE.
5. CLEAR AND GRUB. STRIP ORGANIC SOILS. LOAM SHALL BE STRIPPED FROM THE SITE AS REQUIRED. THE SMALLEST PRACTICAL AREA SHALL BE EXPOSED AT ANY TIME AND SHALL NOT EXCEED ONE ACRE. UNSTABILIZED SOIL SHALL BE TEMPORARILY STABILIZED AS SOON AS PRACTICABLE BUT NO LATER THAN 45 DAYS AFTER INITIAL DISTURBANCE.
6. STABILIZE STOCKPILES. SOIL STOCKPILES SHALL BE LOCATED AND PROTECTED TO MINIMIZE EROSION. INSTALL SILT FENCING AROUND THE BASE OF ALL STOCKPILES ON THE DOWNHILL SIDE.
7. INSPECT AND MAINTAIN ALL EROSION CONTROL MEASURES. ALL PRACTICES ARE TO BE INSPECTED AND MAINTAINED THROUGHOUT THE CONSTRUCTION PERIOD ACCORDING TO RECOMMENDED SCHEDULED, BUT AT LEAST ONCE PER WEEK, AND DURING RAINFALL EVENTS IN WHICH 1/2 INCH OF PRECIPITATION OR MORE FALLS WITHIN A 24 HOUR PERIOD. THE BOTTOM OF SEDIMENT BASINS SHALL BE PERIODICALLY CLEANED, WITH SEDIMENT REMOVED TO A SECURE LOCATION. ALL DAMAGED SILT FENCES SHALL BE REPAIRED. SEDIMENT DEPOSITS SHALL BE PERIODICALLY REMOVED.
8. GRADE AND GRAVEL AREAS TO BE PAVED OR TO REMAIN GRAVEL. ROADWAYS AND PARKING LOTS SHALL BE GRADED, AND UNDERGROUND UTILITIES SHALL BE INSTALLED. GRAVEL SHALL BE INSTALLED AS SOON AS PRACTICAL. THESE AREAS SHALL BE STABILIZED WITHIN 72 HOURS OF ACHIEVING FINISH GRADE. ALL FILL MATERIAL SHALL BE FREE FROM STUMPS, ROOTS, WOOD, ETC.
9. STABILIZE DISTURBED AREAS. BEGIN SEED AND MULCH OF ALL DISTURBED AREAS AS SOON AS PRACTICAL, BUT NO LATER THAN THREE DAYS AFTER FINAL GRADING. ALL CUT AND FILL SLOPES SHALL BE SEEDED AND MULCHED WITHIN 72 HOURS OF ACHIEVING FINISHED GRADE. A MINIMUM OF 6" OF LOAM SHALL BE INSTALLED, WITH SEED, LIME, AND FERTILIZER APPLIED.
10. FINISH PAVING OR FINISH GRADE GRAVEL AREAS. INSTALL FINISH PAVING OR FINISH GRADE GRAVEL SURFACES ON ROADWAYS AND PARKING LOTS.
11. COMPLETE PERMANENT SEEDING AND LANDSCAPING. SPREAD LOAM AND STABILIZE PER PLANS AND SPECIFICATIONS.
12. AN AREA SHALL BE CONSIDERED STABLE IF ONE OF THE FOLLOWING HAS OCCURRED:
  - i) BASE COURSE GRAVELS HAVE BEEN INSTALLED IN AREAS TO BE PAVED;
  - ii) A MINIMUM OF 85% VEGETATED GROWTH HAS BEEN ESTABLISHED;
  - iii) A MINIMUM OF 3" OF NON-EROSIVE MATERIAL SUCH AS STONE OR RIPRAP HAS BEEN INSTALLED; OR
  - iv) EROSION CONTROL BLANKETS HAVE BEEN PROPERLY INSTALLED.
13. REMOVE TEMPORARY EROSION CONTROL MEASURES. AFTER CONSTRUCTION IS COMPLETED AND THE AREAS ARE STABILIZED (MINIMUM 85% VEGETATIVE COVER, BASE COURSE GRAVELS INSTALLED, 3" NON-EROSIVE MATERIAL INSTALLED, OR EROSION CONTROL BLANKET INSTALLED) IN THE DISTURBED AREAS, THE AREAS IN AND AROUND THE TEMPORARY EROSION CONTROL SYSTEMS SHALL BE CLEANED UP, WITH CARE BEING TAKEN NOT TO ALLOW THE ACCUMULATION OF SILT TO RUN INTO THE WETLANDS AND /OR PROTECTED AREAS. AFTER CLEANUP, THE TEMPORARY EROSION CONTROL SYSTEMS SHALL BE REMOVED AND THE AREA RETURNED AS NEAR AS POSSIBLE TO ITS NATURAL STATE.
14. WINTER CONSTRUCTION NOTES:
  - i) ALL PROPOSED VEGETATED AREAS THAT DO NOT EXHIBIT A MINIMUM OF 85% VEGETATIVE GROWTH BY OCTOBER 15, OR WHICH ARE DISTURBED AFTER OCTOBER 15, SHALL BE STABILIZED BY SEEDING AND INSTALLING EROSION CONTROL BLANKETS ON SLOPES GREATER THAN 3:1, AND SEEDING AND PLACING 3 TO 4 TONS OF MULCH PER ACRE, SECURED WITH ANCHORED NETTING, ELSEWHERE. THE INSTALLATION OF EROSION CONTROL BLANKETS OR MULCH AND NETTING SHALL NOT OCCUR OVER ACCUMULATED SNOW OR ON FROZEN GROUND AND SHALL BE COMPLETED IN ADVANCE OF THAW OR SPRING MELT EVENTS.
  - ii) ALL DITCHES OR SWALES WHICH DO NOT EXHIBIT A MINIMUM OF 85% VEGETATIVE GROWTH BY OCTOBER 15 SHALL BE STABILIZED TEMPORARILY WITH STONE OR EROSION CONTROL BLANKETS APPROPRIATE FOR THE DESIGN FLOW CONDITIONS.
  - iii) AFTER OCTOBER 15, INCOMPLETE ROAD OR PARKING SURFACES, WHERE WORK HAS STOPPED FOR THE WINTER SEASON, SHALL BE PROTECTED WITH A MINIMUM 3" OF CRUSHED GRAVEL PER (NHDOT ITEM 304.3)
15. MINIMUM REQUIREMENTS. THE EROSION CONTROL MEASURES SHOWN ON THESE PLANS ARE THE MINIMUM NECESSARY DURING CONSTRUCTION. THE CONTRACTOR SHALL BE RESPONSIBLE FOR ENSURING THAT ADEQUATE EROSION CONTROL PRACTICES ARE EMPLOYED TO PREVENT EROSION AND SEDIMENTATION TO ADJACENT PROPERTIES, ROADS, OR DRAINAGE SYSTEMS.

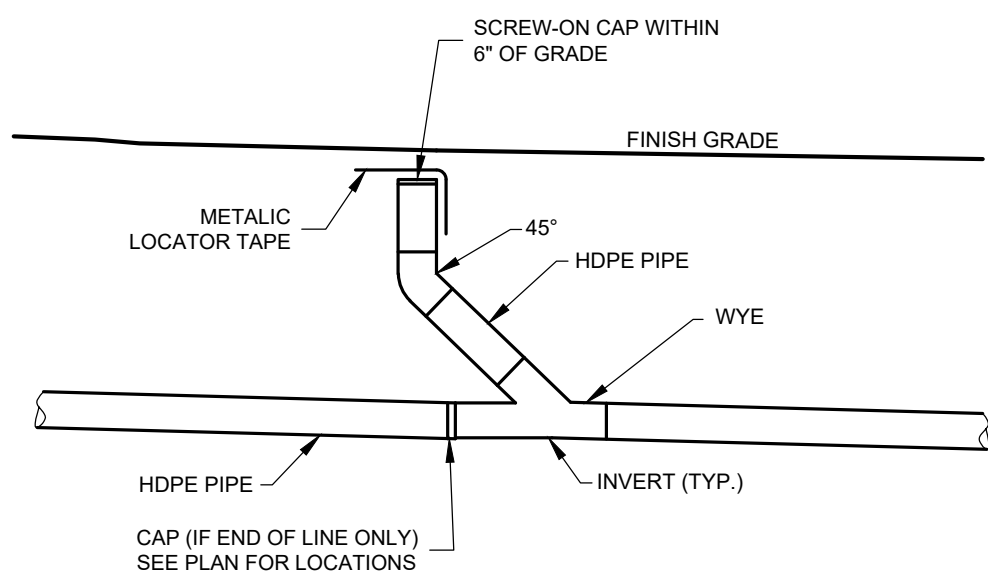

**DRAIN CLEAN OUT**

N.T.S.  
LOCATE AS SHOWN ON PLAN, WITH 200 LF MAXIMUM SPACE

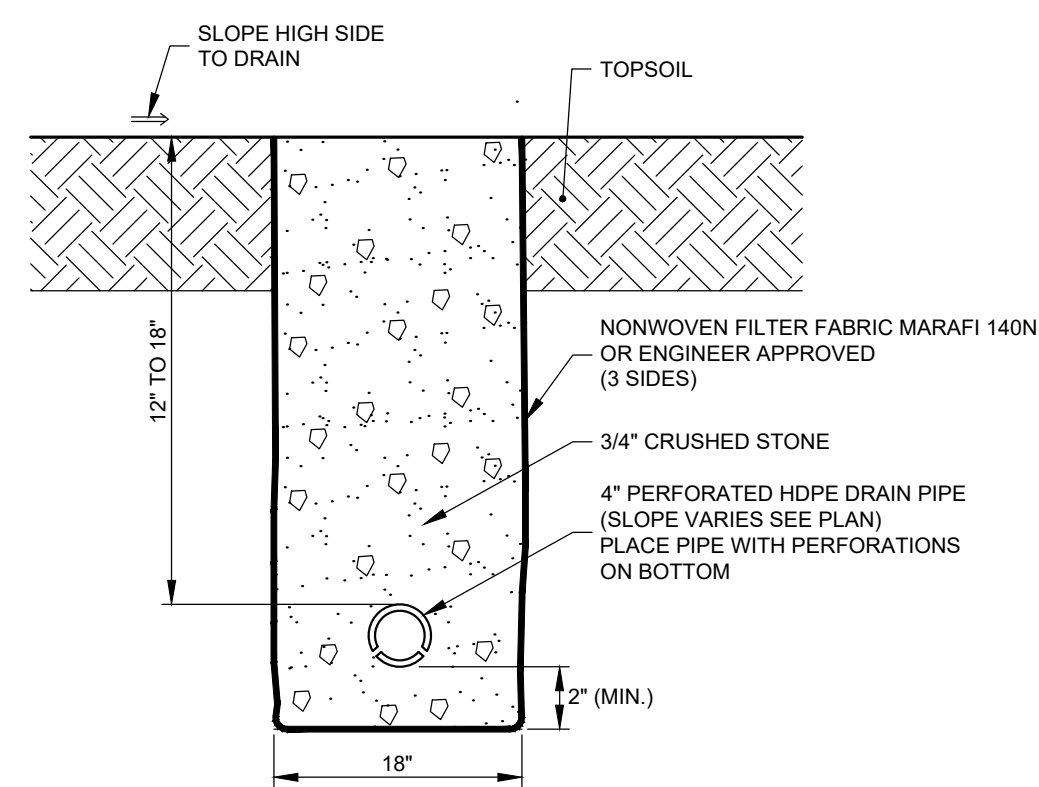

**INTERCEPTOR DRAIN DETAIL**

NOT TO SCALE  
954 LF REQUIRED

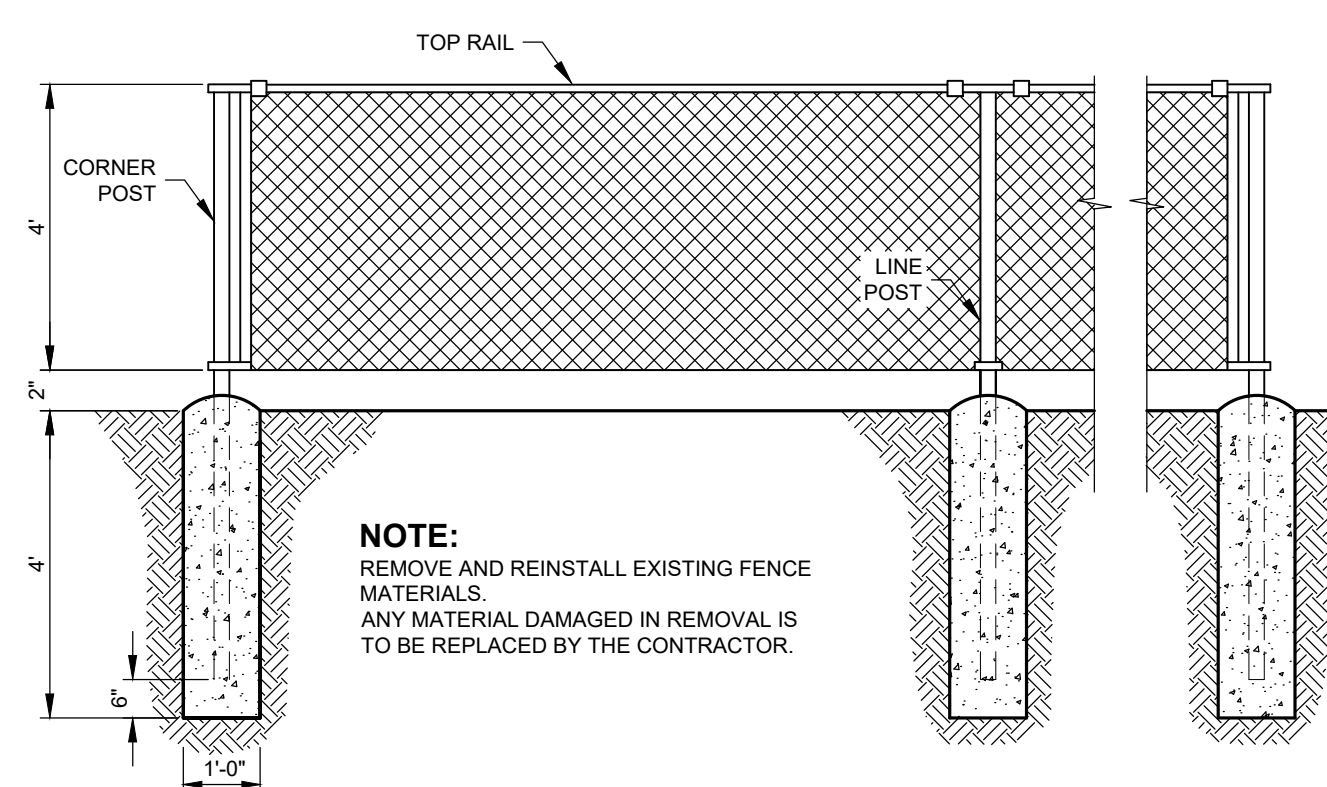

**CHAIN LINK FENCE**

NOT TO SCALE

3	Revised soil profile	3/24/2023
2	Revised filter fabric at interceptor drain detail	6/16/2022
1	Revised playing field soil profile detail and drain detail	2/7/2022
No.	Revision	Date
Designed by: JRB		Checked by: DMF
Drawn by: JRB		

Construction Details  
**Town of Hudson - Freedom Field**  
194 Derry Road  
Hudson, NH  
Assessors Map 138 Lot 89



183 Rockingham Rd, Unit 3 East  
Windham, NH 03087

(603) 647-8700  
www.sfeng.com

Sheet 5 of 5

Scale: As Shown

Date: 6/12/2020

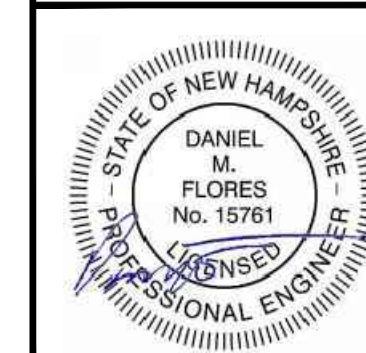

Prepared for:  
Town of Hudson  
12 School Street  
Hudson, NH 03051

Zoning Classification: Residential 1 & Residential 2

